

**TECHNICAL MANUAL OPERATOR
FIELD AND SUSTAINMENT MAINTENANCE
FOR
24,000 BTUH, SPLIT PACK ENVIRONMENTAL CONTROL UNIT (ECU)
NSN 4120-01-516-4715
(EIC: F24H4-2)**

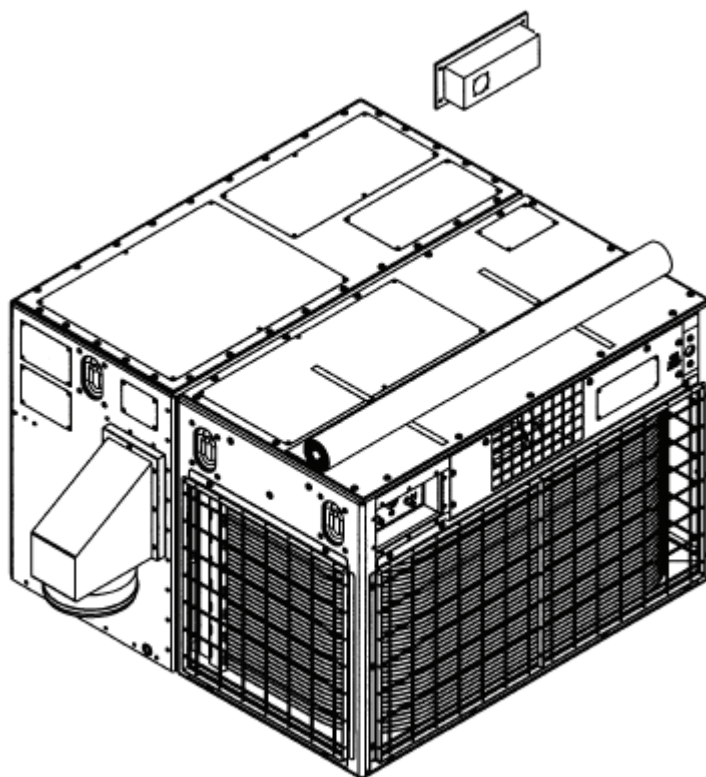

DISTRIBUTION STATEMENT A - Approved for public release; distribution is unlimited.

HEADQUARTERS, DEPARTMENT OF THE ARMY

1 MAY 2007
***This TM supersedes TM 9-4120-429-14, dated 31 August 2006**

WARNING SUMMARY

WARNING

Do not use steam to clean coil.

WARNING



If compressor burnout is suspected, use care when handling compressor to avoid touching compressor sludge. Acid in sludge can cause burns.

WARNING



When handling coils, wear gloves to avoid cuts and reduce fin damage on the coil.

WARNING



Dry cleaning solvent is flammable, and their vapors can be explosive. Repeated or prolonged skin contact or inhalation of vapors can be toxic. Use a well-ventilated area, and keep away from sparks or flame. Use goggles, gloves, and apron when appropriate.

WARNING SUMMARY (Continued)

WARNING



Avoid inhaling refrigerant tR-410A .Do not inhale fumes from any acid formed by burnout of oil. Wear protective goggles or glasses to protect eyes. Wear rubber gloves to protect hands. Use care to avoid spilling compressor burn out sludge. If sludge is spilled, clean area thoroughly.

WARNING



The burning of polyurethane foams is dangerous. Due to chemical composition of polyurethane foam, toxic fumes are released when It is burned or heated. If it is burned or heated indoors, such as during a welding operation nearby, you should take care to ventilate the area thoroughly. An exhaust system like that of a paint spray booth should be used. Air-supplied respirators, approved by the National Institute for Occupational Safety and Health Administration or the United States Bureau of Mines, should be used for all welding in confined spaces and in places where ventilation may be inadequate. Persons, who have chronic or recurrent respiratory conditions, including allergies and asthma, should not work in these areas.

WARNING



Dangerous chemicals are used in this equipment. DEATH or serious injury may result if personnel fail to observe proper safety precautions. Great care must be exercised to prevent contact of liquid Refrigerant R-410A, or Refrigerant R-410A gas discharged under pressure, with any part of the body. The extremely low temperature resulting from the rapid expansion of liquid Refrigerant R-410A, or Refrigerant R-410A gas released under pressure, can cause sudden and irreversible tissue damage through freezing. As a minimum, all personnel must wear thermal protective gloves and a face shield or goggles when working in any situation where Refrigerant R-410A contact with the skin or eyes is possible. Application of excessive heat to any component in a charged system will cause extreme pressure that may result in a rupture, possibly explosive in nature.

WARNING SUMMARY (Continued)

WARNING



Exposure of Refrigerant R-410A to an open flame or a very hot surface will cause a chemical reaction in the gas to form carbonyl chloride (phosgene), a highly toxic and corrosive gas. In its natural state, Refrigerant R-410A is a colorless odorless vapor with no toxic characteristics. It is lighter than air and in a well-ventilated area will disperse rapidly. However, suffocation is possible in unventilated areas.

WARNING



REFRIGERANT R-410A UNDER PRESSURE is used in the operation of this equipment. DEATH or severe injury may result if you fail to observe safety precautions. Never use a heating torch on any part that contains Refrigerant R-410A. Do not let refrigerant touch you, and do not inhale refrigerant gas.

WARNING



HIGH VOLTAGE is used in the operation of this equipment. DEATH ON CONTACT may result if personnel fail to observe safety precautions. Never work on electrical equipment unless there is another person nearby who is familiar with the operation and hazards of the equipment and who is competent in administering first aid. When an operator aids the technician, he/she must warn them about dangerous areas. Whenever possible, the input power supply to the equipment must be shut off before beginning work on the Equipment. Take particular care to ground every capacitor likely to hold a dangerous potential. When working inside the equipment, after the power has been turned off, always ground every part before touching it. Be careful not to contact high-voltage connections of 208 volts ac input when installing or operating this equipment. Whenever the nature of the operation permits, keep one hand away from the equipment to reduce the hazard of current flowing through vital organs of the body.

WARNING SUMMARY (Continued)

WARNING



Do not be misled by the term "low voltage." Potentials as low as 50 volts may cause death under adverse conditions. Disconnect input power to the Environmental Control Unit (ECU) before performing any maintenance to the electrical system. Voltages used can be lethal. Shutting the unit off at the control module does not disconnect power to the various components of the Environmental Control Unit.

WARNING



Allow heaters to cool before touching. Severe burns can result from touching hot heaters.

WARNING



AC power tests must be conducted with the power on. Exercise extreme caution.

WARNING



Do not allow anyone under equipment suspended from a lifting device. Do not allow the unit to swing while suspended from a lifting device. Failure to observe this warning may result in injury to personnel and damage to the equipment.

WARNING SUMMARY (Continued)

WARNING



Do not operate the equipment without all grilles, guards, louvers, and covers in place and tightly secured.

WARNING



The covers, grilles, and screens installed on this unit are there for a purpose. Do not operate this unit with them off or open unless the instructions direct you. When this is necessary, do so with care.

WARNING



Hearing protection is required when operating or performing maintenance on the ECU where decibel levels are in excess of 85db.

WARNING



Compressed air used for cleaning purposes will not exceed 30PSI (2.1kg/squarecentimeter). Do not direct compressed air against the skin. Use goggles or full-face shield.

WARNING SUMMARY (Continued)

WARNING



Be sure the refrigeration system is fully discharged and purged and that dry nitrogen is flowing through the system at the rate of less than 1-2cfm (0.028-0.057cubicmeters/minute) before all brazing or debrazing operations.

WARNING



Refrigerant R-410A must be recaptured in a recycling/reclaiming machine.

WARNING



Do not attempt any disassembly of the solenoid valve other than coil removal with a Refrigerant R-410A charge in the system. Refrigerant R-410A will be sprayed out dangerously if the screws that attach the tube and plunger assembly to the valve body are loosened.

WARNING



Ensure that no source of dangerous or objectionable fumes is near the fresh air intake.

WARNING



Ensure Remote Control Unit mode selector knob is in the "OFF" position prior to connecting.

WARNING SUMMARY (Continued)

WARNING



FLAMMABLE solvents and cleaning materials are used in the cleaning and maintenance of this equipment. Do not use flammables in areas where open flame or other ignition sources are present. Be sure that adequate ventilation is provided. Avoid inhalation of flammable liquids. Properly dispose of rags and other materials contaminated with flammable liquids. Have flame extinguishing equipment readily available when using flammable materials.

WARNING



Avoid injury by using adequate equipment and personnel to remove compressor from frame. The compressor weighs 65pounds (30kg). Two-person lift is required.

WARNING



Nitrogen cylinders are pressurized containers. The pressure in the cylinder can exceed 2000 psi. A nitrogen pressure regulator should be used at all times when nitrogen is used for leak check or purge operations. Nitrogen is an inert gas. However, it also presents danger as a suffocation hazard and, therefore, must also be discharged in a ventilated location.

WARNING



During lifting operations, the mechanics must be visible to the lifting device operator and in a position to physically guide the Environmental Control Unit as it is lifted into position.

CAUTION SUMMARY

CAUTION

Do not operate the Environmental Control Unit in the COOL mode if the refrigerant color has reached the yellow band or if numerous bubbles appear in the sight glass. COOL mode operation may be continued with the refrigerant color in the chartreuse band or with only an occasional bubble appearing in the window, but the sight glass should be rechecked after each four hours of operation to ensure that the condition has not become worse.

CAUTION

Turn the Environmental Control Unit to OFF as soon as a definite drop in temperature is felt on the suction return line. If the test conditions are continued more than few seconds, the thermostatic valve willfully open and an excessive flood-back of liquid Refrigerant R-410A may damage or destroy the compressor.

CAUTION

Connect and invert the Refrigerant R-410A container so that only gas will be used for pressurization.

CAUTION

Never introduce liquid Refrigerant R-410A in to the low-pressure (suction) service valve.

CAUTION

If there is a loud banging noise coming from the condenser section when the unit is operated in the COOL mode, immediately turn the MODE SELECTOR SWITCH to OFF. Allow at least one hour of warm up time before attempting a restart in the COOL mode.

CAUTION

If military operational considerations allow the time, it will help extend the life of the compressor if the Environmental Control Unit is not turned on for its check of operation in the COOL mode until after a sufficient time to eliminate any danger of liquid refrigerant accumulation in the compressor. Except in extremely cold conditions, if input power has been disconnected for a period of less than six hours, an equal warm-up period is desirable. If the disconnected period has been more than six hours, a full six-hour warm-up period is recommended.

CAUTION

Use care in handling to avoid damage to the Environmental Control Unit. If an overhead lifting device must be used, use an appropriate sling so that the weight of the unit is borne by the base of the shipping container.

CAUTION SUMMARY (Continued)

CAUTION

Failure to remove drain plugs will cause water to collect in the bottom of the evaporator section assembly and possible spillage into shelter.

CAUTION

If the soap solution testing method is used, thoroughly rinse with fresh water after testing is completed. A residual soap film will attract and accumulate an excessive amount of dust and dirt during operation.

CAUTION

Don't evacuate a leaking system. The vacuum created can cause air, moisture, and dirt to enter system.

CAUTION

Use care to not damage or kink the capillary.

CAUTION

Do not permit the oil to escape from the unit. If oil is escaping, close the valve(s) slightly. Do not permit the refrigerant to escape fast enough to form ice or frost on either the lines or the valve.

CAUTION

The compressor is supplied with a complete charge of oil. Take care that oil is not lost when handling and installing compressor.

CAUTION

Replacement dehydrators are packaged with sealing caps on the flare fittings, to prevent moisture contamination of the desiccant filtering media. Remove these caps immediately prior to installation. Never install a dehydrator from which caps have been removed for an extended or unknown period of time.

LIST OF EFFECTIVE PAGES

INSERT LATEST CHANGED PAGES, DESTROY SUPERSEDED PAGES

NOTE: This manual supersedes TM 9-4120-429, dated 31 August 2006. Zero in the "Change No." column indicates an original page

Dates of issue for revision is:

Original 01 May 2007

TOTAL NUMBER OF PAGES FOR FRONT AND REAR MATTER IS TWENTY-FOUR AND TOTAL NUMBER OF WORK PACKAGES IS FORTY-NINE, CONSISTING OF THE FOLLOWING:

Page No.	* Change No.	Page No.	* Change No.
Cover.....	0	WP0023 00 (4 pgs).....	0
Blank.....	0	WP0024 00 (4 pgs).....	0
a -i.....	0	WP0025 00 (6 pgs).....	0
j Blank.....	0	WP0026 00 (4 pgs).....	0
A.....	0	WP0027 00 (6 pgs).....	0
B Blank.....	0	WP0028 00 (4 pgs).....	0
i - iii.....	0	WP0029 00 (4pgs).....	0
iv Blank.....	0	WP0030 00 (4 pgs).....	0
Chp 1 title page.....	0	WP0031 00 (4 pgs).....	0
Chp 1 Index.....	0	WP0032 00 (4 pgs).....	0
WP0001 00 (4 pgs).....	0	WP0033 00 (4 pgs).....	0
WP0002 00 (6 pgs).....	0	WP0034 00 (6 pgs).....	0
WP0003 00 (4 pgs).....	0	WP0035 00 (2pgs).....	0
Chp 2 title page.....	0	WP0036 00 (4pgs).....	0
Chp 2 Index.....	0	WP0037 00 (2 pgs).....	0
WP0004 00 (2 pgs).....	0	WP0038 00 (18 pgs).....	0
WP0005 00 (20 pgs).....	0	WP0039 00 (4 pgs).....	0
WP0006 00 (2 pg).....	0	WP0040 00 (4 pgs).....	0
Chp 3 title page.....	0	WP0041 00 (2 pgs).....	0
Chp 3 Index.....	0	WP0042 00 (4 pgs).....	0
WP0007 00 (2 pg).....	0	WP0043 00 (4 pgs).....	0
WP0008 00 (14 pgs).....	0	WP0044 00 (2 pgs).....	0
Chp 4 title page.....	0	WP0045 00 (8 pgs).....	0
Chp 4 Index.....	0	Chp 5 title page.....	0
WP0009 00 (2 pg).....	0	Blank.....	0
WP0010 00 (4 pgs).....	0	WP0046 00 (2 pgs).....	0
WP0011 00 (2 pg).....	0	WP0047 00 (4 pgs).....	0
WP0012 00 (2 pgs).....	0	WP0048 00 (6 pgs).....	0
WP0013 00 (6 pgs).....	0	WP0049 00 (2pgs).....	0
WP0014 00 (4 pgs).....	0	Chp 6 title page.....	0
WP0015 00 (8 pgs).....	0	Blank.....	0
WP0016 00 (4 pgs).....	0	Index 1 - Index 5.....	0
WP0017 00 (10 pgs).....	0	Index 6 Blank.....	0
WP0018 00 (4 pgs).....	0	Blank.....	0
WP0019 00 (10 pgs).....	0	Cover.....	0
WP0020 00 (4 pgs).....	0		
WP0021 00 (4pgs).....	0		
WP0022 00 (2 pgs).....	0		

A/B Blank

HEADQUARTERS,
DEPARTMENT OF THE ARMY
WASHINGTON D.C., 1 May 2007

TECHNICAL MANUAL

**FIELD AND SUSTAINMENT MAINTENANCE FOR
ENVIRONMENTAL CONTROL UNIT (ECU), 24,000 BTUH, SPLIT PACK**

NSN 4120-01-516-4715

(EIC: F24H4-2)

REPORTING ERRORS AND RECOMMENDING IMPROVEMENTS

You can help improve this manual. If you find any mistakes or if you know of a way to improve the procedures, please let us know. Reports, as applicable by the requiring Service, should be submitted as follows: Mail your letter or DA Form 2028 (Recommended Changes to Publications and Blank Forms) located in the back of this manual, directly to: Commander, U.S. Army Communications-Electronics Life Cycle Management Command (C-E LCMC) and Fort Monmouth, ATTN: AMSEL-LC-LEO-E-ED, Fort Monmouth, NJ 07703-5006. You may also send in your recommended changes via electronic mail or by fax. Our fax number is 732-532-3421, DSN 992-3421. Our e-mail address is MONM-AMSELLEOPUBSCHG@conus.army.mil. Our online web address for entering and submitting DA Form 2028s is <http://edm.monmouth.army.mil/pubs/2028.html>.

DISTRIBUTION STATEMENT A. Approved for public release; distribution is unlimited.

***This TM supersedes TM 9-4120-429-14, dated 31 August 2006**

TABLE OF CONTENTS

FRONT MATTER-

Warning Summary	a
Title Block.....	i
How to Use this Manual	iii
List of Effective Pages	A

WORK PACKAGE INDEX

<u>Title</u>	<u>WP Sequence No.</u>
CHAPTER 1 - Introduction	
GENERAL INFORMATION	0001 00
ENVIRONMENTAL CONTROL UNIT EQUIPMENT DESCRIPTION AND DATA	0002 00
THEORY OF OPERATION	0003 00
 CHAPTER 2 - Operating Instructions	
DESCRIPTION AND USE OF OPERATOR'S CONTROLS AND INDICATORS	0004 00
OPERATION UNDER USUAL CONDITIONS.....	0005 00
OPERATION UNDER UNUSUAL CONDITIONS.....	0006 00
 CHAPTER 3 - Troubleshooting Procedures	
MALFUNCTION/SYMPTOM INDEX	0007 00
OPERATIONAL CHECKOUT AND TROUBLESHOOTING PROCEDURES	0008 00
 CHAPTER 4 - Maintenance Instructions	
SERVICE UPON RECEIPT.....	0009 00
FIELD PREVENTIVE MAINTENANCE CHECKS AND SERVICES (PMCS).....	0010 00
MAINTENANCE INSTRUCTIONS	0011 00
EVAPORATOR ASSEMBLY AND CONDENSER ASSEMBLY SEPARATION AND RECONNECTION.....	0012 00
EVAPORATOR ASSEMBLY	0013 00
EVAPORATOR HOUSING ASSEMBLY	0014 00
EVAPORATOR COIL ASSEMBLY	0015 00
HEATER ASSEMBLY.....	0016 00
EVAPORATOR BLOWER AND MOTOR ASSEMBLY	0017 00
VARIABLE FREQUENCY DEVICE (VFD)	0018 00
EVAPORATOR COVERS	0019 00
HARMONIC FILTER FL2	0020 00
EVAPORATOR HARNESS ASSEMBLIES	0021 00
EXPANSION (THERMOSTATIC) VALVE.....	0022 00
CONDENSER ASSEMBLY	0023 00
JUNCTION BOX ASSEMBLY.....	0024 00
CONDENSER COVERS	0025 00
CONDENSER COIL ASSEMBLY	0026 00
CONDENSER BLOWER AND MOTOR ASSEMBLY	0027 00
CONDENSER HOUSING	0028 00
RECEIVER ASSEMBLY.....	0029 00

<u>Title</u>	<u>WP Sequence No.</u>
FILTER-DRYER REFRIGERANT	0030 00
SIGHT GLASS	0031 00
LOW PRESSURE SWITCH	0032 00
HIGH PRESSURE SWITCH	0033 00
COMPRESSOR ASSEMBLY.....	0034 00
REMOTE CONTROL ASSEMBLY.....	0035 00
CONDENSER HARNESS ASSEMBLIES	0036 00
ELECTRICAL WIRING REPAIR GENERAL	0037 00
WIRE LIST	0038 00
REFRIGERANT R-410A PRESSURE CHECK.....	0039 00
LEAK TESTING THE REFRIGERANT R-410A SYSTEM	0040 00
EVACUATING THE REFRIGERANT R-410A SYSTEM	0041 00
CHARGING THE REFRIGERANT R-410A SYSTEM	0042 00
BRAZING/DEBRAZING PROCEDURES	0043 00
FINISH REPAINTING AND REFINISHING GENERAL	0044 00
WIRING DIAGRAMS.....	0045 00

CHAPTER 5 - Supporting Information Module

SUPPORTING DATA WORK PACKAGE FOR REPAIR PART SPECIAL TOOLS, TMDE, AND SUPPORT EQUIPMENT.....	0046 00
THE ARMY MAINTENANCE SYSTEM MAC	0047 00
MAINTENANCE ALLOCATION CHART	0048 00
COMPONENTS OF END ITEM (COEI) and BASIC ISSUE	0049 00

CHAPTER 6 - Index

HOW TO USE THIS MANUAL

This manual is divided into chapters, and work packages numbered in sequence. Figures and tables are also numbered in sequence.

FINDING INSTRUCTIONS YOU NEED

Chapter, Work Package, Work Package titles and page numbers are listed in the Table of Contents.

Figure numbers and titles are listed in List of Illustrations, table numbers and titles in List of Tables.

Subject Index is in the back of the manual. Index lists all subjects in the manual in alphabetical order with Work Package numbers.

The malfunction/symptom index (WP 0007 00) is a quick reference index for finding troubleshooting procedures. Associated with each symptom name is a work package sequence number representing the starting point in a troubleshooting sequence. Should any one symptom require more than one troubleshooting sequence, the additional starting point numbers are presented.

As the troubleshooting activity progresses through to the conclusion of a particular sequence, a reference is made to the next logical troubleshooting sequence by work package sequence number. This type of activity continues until successful fault isolation is achieved.

Chapter 1

OPERATOR

24,000 BTUH, SPLIT PACK ENVIRONMENTAL CONTROL UNIT (ECU)

NSN 4120-01-516-4715 F24H4-2

CHAPTER 1

OPERATOR
INTRODUCTION

WORK PACKAGE INDEX

<u>Title</u>	<u>WP Sequence No.</u>
GENERAL INFORMATION.....	0001 00
ENVIRONMENTAL CONTROL UNIT (ECU) EQUIPMENT DESCRIPTION AND DATA.....	0002 00
THEORY OF OPERATION	0003 00

OPERATOR

24,000 BTUH, SPLIT PACK ENVIRONMENTAL CONTROL UNIT (ECU)

NSN 4120-01-516-4715 F24H4-2

GENERAL INFORMATION

0001 00

SCOPE

- a. **Type of Manual.** Field and Sustainment Maintenance Manual
- b. **Model Number and Equipment Name.** Model F24H4-2, Environmental Control Unit (ECU), Split-Pack 24,000 BTUH.
- c. **Purpose of equipment.** Cools, heats, and ventilates enclosed space (shelter). The unit covered by this manual is designed for cooling and heating air to a desired predetermined range and circulating the conditioned air to provide heating and cooling of equipment or personnel within the conditioned area.

MAINTENANCE FORMS, RECORDS, AND REPORTS

Department of the Army forms and procedures used for equipment maintenance will be those prescribed by DA PAM 750-8, The Army Maintenance Management System(TAMMS)Users Manual.

EQUIPMENT IMPROVEMENT RECOMMENDATION (EIR)

If your Environmental Control Unit needs improvement, let us know. Send us an EIR. You, the user are the only one who can tell us what you don't like about your equipment. Let us know why you don't like the design or performance. Put it on a SF 368 (Product Quality Deficiency Report). Mail it to the address specified in DA PAM 750-8, The Army Maintenance Management System(TAMMS)Users Manual , or as specified by the contracting activity. We will send you a reply.

CORROSION PREVENTION AND CONTROL

Corrosion Prevention and Control (CPC) of Army materiel is a continuing concern. It is important to report any corrosion problems with this item so that problems can be corrected and improvements performed to prevent the problem in future items.

While corrosion is typically associated with rusting of metals, it can also include deterioration of other materials such as rubber and plastic. Unusual cracking, softening, swelling, or breaking of these materials may be a corrosion problem.

If a corrosion problem is identified, it can be reported using SF 368, Product Quality Deficiency Report. Use of key words such as "corrosion", "rust", "deterioration", or "cracking" will ensure that the information is identified as a CPC problem.

The form should be submitted to the address specified in DA PAM 750-8, The Army Maintenance Management System (TAMMS) Users Manual.

DESTRUCTION OF ARMY MATERIEL TO PREVENT ENEMY USE

Command decisions, according to tactical situation, will determine when destruction of the air conditioning unit will be accomplished. A destruction plan will be prepared by the using organization, unless higher authority has prepared one. For general destruction procedures for this equipment, refer to TM 750-244-3, Procedures for Destruction of Equipment to Prevent Enemy Use.

PREPARATION FOR STORAGE OR SHIPMENT

A. GENERAL

See WP 0005 00, INSTALLATION SITE PREPARATION for removal instructions.

Condensate drains, one each side, should be cleaned out with a brush. They should be plugged with original pipe plugs, if available, or covered with tape to prevent entrance of foreign objects and insects.

B. ADMINISTRATIVE STORAGE OF EQUIPMENT

Administrative storage is short-term storage - 1 to 45 days. It covers storage of equipment, which can be readied for mission performance within 24 hours. Before placing an item in administrative storage, the next scheduled preventive maintenance checks and services should be performed, all known deficiencies corrected and all current modification work orders applied. The administrative storage site should provide required protection from the elements and allow access for visual inspection when applicable.

C. INTERMEDIATE STORAGE

Storage of 46 to 180 days. No special handling is required other than protection from damage and the elements. Place the Environmental Control Unit in a dry, covered area.

D. LONG-TERM STORAGE

There is no time limit for this type of storage.

Bolt the Environmental Control Unit to a wood skid base. If the original shipping skid base was kept, use it. If not, fabricate a new one.

Wrap the Environmental Control Unit with two layers of heavy plastic sheet or barrier paper.

Tape and strap the wrapping in place

Mark the Environmental Control Unit per standard Army Procedures

WARRANTY REFERENCES

The Environmental Control Unit is warranted for one (1) year. The warranty starts on the date found in block 23 of DA Form 2408-9, Equipment Control Record. All warranty claim actions will be processed through the local WARCO Office established at the intermediate General Support Level.

NOMENCLATURE CROSS REFERENCE LIST

This listing includes nomenclature cross reference used in this manual.

Environmental Control Unit

LIST OF ABBREVIATIONS AND ACRONYMS

Term	Definition
MAC	Maintenance Allocation Chart
MEK	Methyl-Ethyl Ketone

Term	Definition
MTOE	Modified Table of Organization and Equipment
NBC	Nuclear-Biological-Chemical
PMCS	Preventive Maintenance Checks & Services
TAMMS	The Army Maintenance Management System
TMDE	Test, Maintenance, and Diagnostic Equipment
U/M	Unit of Measure
VFD	Variable Frequency Device

SAFETY, CARE, AND HANDLING INFORMATION

NOTE

Environmental Control Unit schematic diagrams do not depict shelter electrical connectors. Evaporator Main Power connector (J1) and Remote Control connector (J2) connect to vehicle shelter Main Power cable connector (J8) and Remote Control cable connector (J7) . Remote Control Unit connector (P2) connects to vehicle shelter Remote Control cable connector (J14).

Ensure power is isolated from the environmental control unit prior to servicing or maintenance. Remove power cables and grounding straps from the unit prior to removal of the unit. The ECU weighs in excess of 320 pounds. Use lifting devices such as lift trucks to remove the unit from the vehicle. Personnel should wear gloves and steel toe footwear when installing or removing the ECU. Cuts, abrasions and burns can occur when coming in contact with evaporator coils and compressor components.

END OF WORK PACKAGE

OPERATOR

24,000 BTUH, SPLIT PACK ENVIRONMENTAL CONTROL UNIT (ECU)

NSN 4120-01-516-4715 F24H4-2

ENVIRONMENTAL CONTROL UNIT EQUIPMENT DESCRIPTION AND DATA

0002 00

CHARACTERISTICS, CAPABILITIES AND FEATURES

NOTE

Environmental Control Unit schematic diagrams do not depict shelter electrical connectors. Evaporator Main Power connector (J1) and Remote Control connector (J2) connect to vehicle shelter Main Power cable connector (J8) and Remote Control cable connector (J7). Remote Control Unit connector (P2) connects to vehicle shelter Remote Control cable connector (J14).

Remote Control Assembly - The Remote Control Assembly has the Mode Selector Switch for choosing between OFF, FAN, COOL, HI HEAT and LO HEAT, a rotary Temperature Control for controlling temperature regardless of operating mode, and a visual indicator for power ON/OFF conditions.

Evaporator Assembly - The Evaporator Assembly exhausts conditioned air, and intakes return air. It has an opening on either side for ventilating outside air; these openings have fresh air covers installed. These openings will accommodate mounting of fresh air duct assemblies. This assembly also has the connection points for the input power cable and the remote control cable.

Condenser Assembly - A sight glass is included on the assembly exterior for visually inspecting the refrigerant during the Cool Mode. Both a low side and a high side service valve are provided for use during maintenance, service and testing. Also, a High Pressure Cutout (Reset) Switch is on the assembly for resetting the switch, which has opened because of excessive refrigerant pressure.

NOTE

The power cable assembly and the remote control cable assemblies are not provided as part of the Environmental Control Unit. See installation instructions contained in WP 0005 00, INSTALLATION SITE PREPARATION for general instructions and the manual for shelter on which Environmental Control Unit is to be installed for specific instructions pertaining to these cables.

The Model F24H4-2 Environmental Control Unit is designed to circulate and cool or heat air in the shelter or enclosure on which it is installed.

The Model F24H4-2 has a capability of providing 24,000 BTUH of cooling and two stages of heat rated at 18,000 BTUH (Low) and 30,000 BTUH (High). It is designed to maintain the air in the shelter or enclosure at the desired temperature selected on the remote control assembly.

The unit is a split package Environmental Control Unit that is ideally suited for van or shelter type installations.

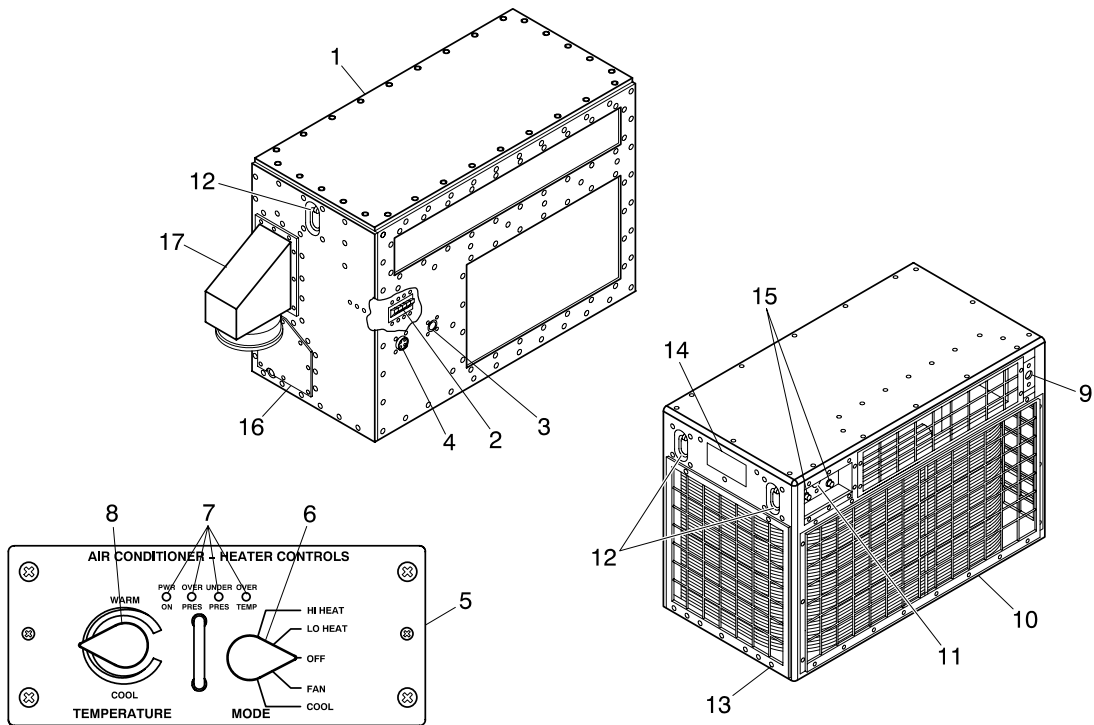

Figure 1. LOCATION OF MAJOR COMPONENTS.

INSTALLATION SITE PREPARATION

External requirements are a source of 208 volt ac, 3 phase, 400 hertz input power, power cable, remote control cables, and a entry to a suitable drain (lower than the base of the evaporator assembly in its operating location), for disposal of condensate waste water.

The Environmental Control Unit is designed to operate in almost any environmental condition from arctic to tropic and is fully portable for movement from one location to another.

The installation requirements are covered in the installation instructions contained in WP 0005 00,

1. EVAPORATOR ASSEMBLY

2. CIRCUIT BREAKER (Internal). Allows connection/disconnection of main power source.

3. REMOTE CONTROL CONNECTOR (J2). Connection point for remote control cable.

4. POWER CONNECTOR (J1). Connection point for input 208 volt, 3 phase, 400 Hz power cable.

5. REMOTE CONTROL UNIT

6. MODE SELECTOR SWITCH. Selects off, fan, cool , LO heat, and HI heat modes of operation. Power on indicator lamp illuminates when any mode other than off is selected.

7. REMOTE CONTROL UNIT INDICATOR LAMPS. Indicates operational mode selected by the mode selector switch.
8. TEMPERATURE CONTROL KNOB. Allows adjustment and control of the temperature when operating in the cool or heat modes. Increases temperature when rotated in the clockwise direction. Decreases temperature when rotated in the counter-clockwise direction.
9. OVER PRESSURE MANUAL RESET BUTTON. Releases over pressure condition of compressor when depressed.
10. DUST COVER. Prevents coil damage to coils by dust and debris.
11. SIGHT GLASS. Allows visual inspection and indicates the condition of the liquid refrigerant when the unit is operating in the COOL mode.
12. LIFT RING. Provides lift point for hoisting unit.
13. DRAIN HOLE. Allows condensation to exit the unit.
14. NAME PLATE. Information data.
15. LOW and HIGH SIDE SERVICE VALVES. Provides a connection point for maintenance, testing, and service. Unauthorized personnel should not tamper with these valves.
16. HOUSING ACCESS COVER ASSEMBLY. Allows access to Evaporator Assembly interior.
17. FRESH AIR DUCT. Allows fresh air to enter evaporator.

Table 1. Equipment Data

DESCRIPTION	VALUES
COOLING CAPACITY	24,000 BTUH
HEATING CAPACITY	
LOW HEAT MODE	18,000 BTUH
HIGH HEAT MODE	30,000 BTUH
POWER REQUIRED	
VOLTAGE	208
PHASE	3
HERTZ	400
AMPERES, MAXIMUM (Steady State)	30.0
WATTS ,RUNNING (MAXIMUM)	7,800
DIMENSIONS EVAPORATOR SECTION	

Table 1. Equipment Data (continued)

DESCRIPTION	VALUES
WIDTH	32.09in.(815.09cm)
DEPTH	15.06in.(382.52cm)
HEIGHT	22.06in.(560.32cm)
CONDENSER SECTION	
WIDTH	32.02in.(813.33cm)
DEPTH	17.21in.(437.20cm)
HEIGHT	22.15in.(562.61cm)
REMOTE CONTROL	
WIDTH	8.25in.(20.96cm)
DEPTH	5.65in.(14.35cm)
HEIGHT	3.50in.(8.89cm)
WEIGHT(TOTAL)	320.0lbs.(145.28kg.)
REFRIGERANT	
TYPE	R-410A
CHARGE	4.9 lbs.

DECALS AND INSTRUCTION PLATES

1.

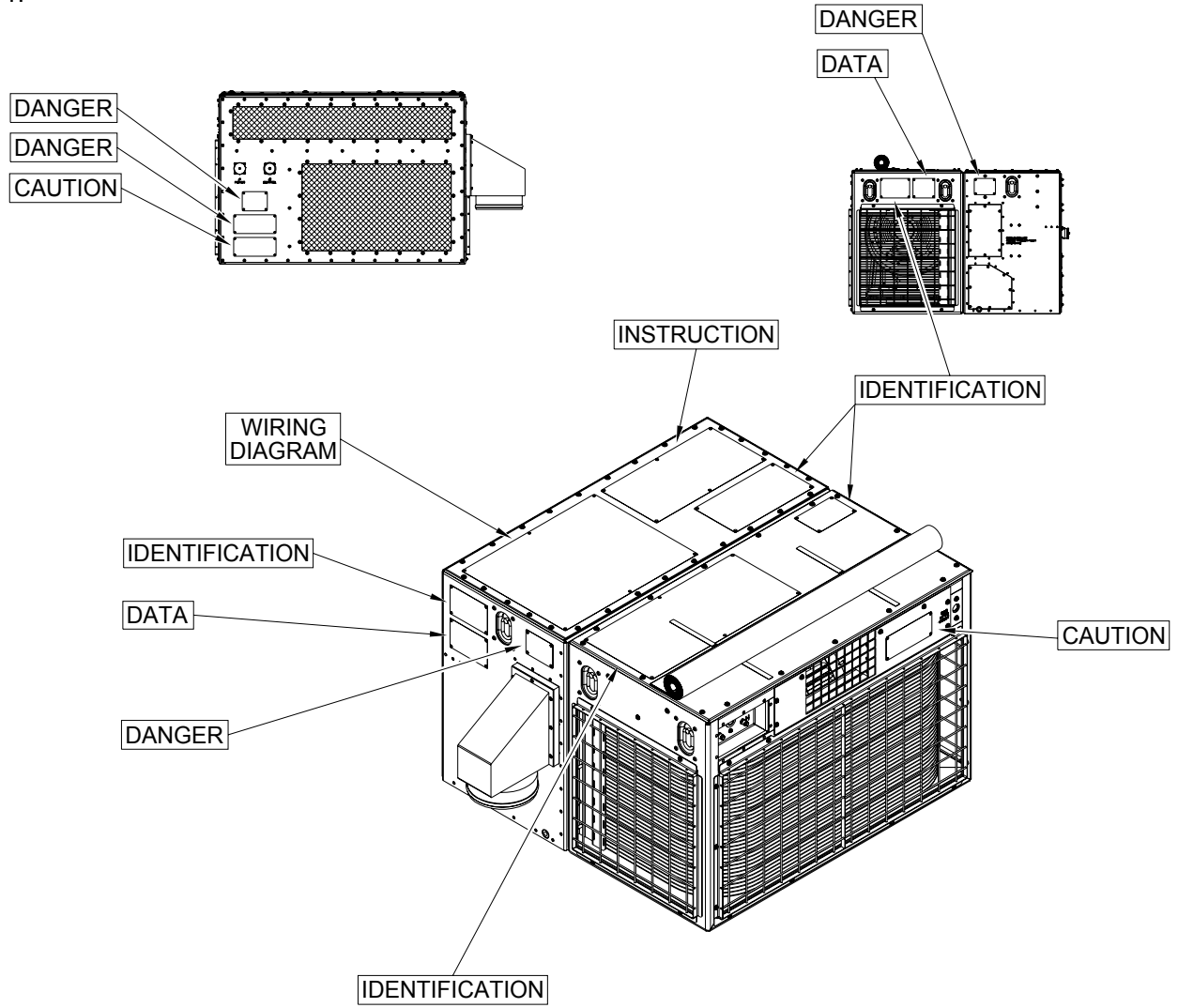

Figure 2. DECAL AND INSTRUCTION PLATE LOCATIONS.

END OF WORK PACKAGE

OPERATOR

24,000 BTUH, SPLIT PACK ENVIRONMENTAL CONTROL UNIT (ECU)

NSN 4120-01-516-4715 F24H4-2

THEORY OF OPERATION

0003 00

SYSTEM OPERATION

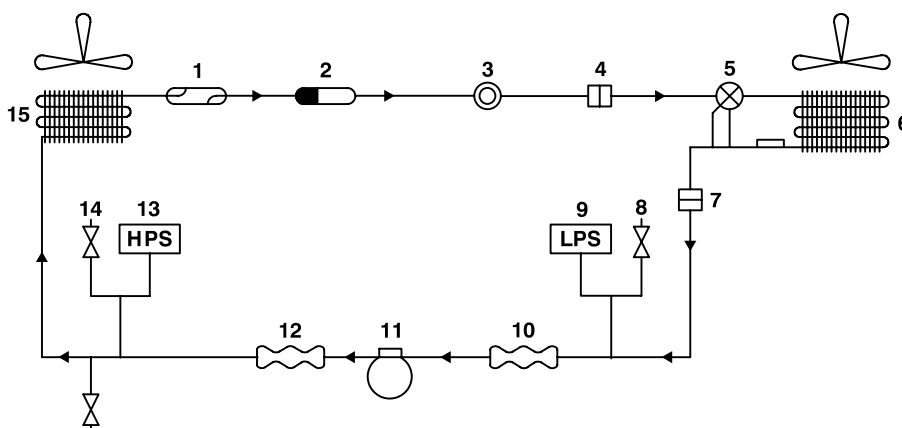

LEGEND	
ITEM	DESCRIPTION
1	RECEIVER, LIQUID REFRIGERANT
2	FILTER, DRYER
3	MOISTURE LIQUID INDICATOR
4	QUICK DISCONNECT, REFRIGERANT
5	THERMOSTATIC EXPANSION VALVE
6	EVAPORATOR
7	QUICK DISCONNECT, REFRIGERANT
8	SUCTION SERVICE VALVE
9	LOW PRESSURE SWITCH
10	METAL HOUSE ASSEMBLY, SUCTION
11	COMPRESSOR
12	METAL HOUSE ASSEMBLY, DISCHARGE
13	HIGH PRESSURE SWITCH
14	DISCHARGE SERVICE VALVE
15	CONDENSER

Figure 1. COOLING CYCLE.

COOLING CYCLE

When the MODE SELECTOR SWITCH and the TEMPERATURE CONTROL are set for COOL, the following takes place:

1. The compressor (11) takes cold, low pressure refrigerant gas and compresses it to a high temperature, high pressure gas. This gas flows through the metal hose assembly (12) to the condenser coil (15) and receiver (1).
2. The condenser fan draws outside ambient air over and through the condenser coil (15). The high temperature, high-pressure gas from the compressor (11) is cooled by the flow of air and is changed into a high-pressure liquid.
3. The refrigerant desiccant dehydrator (filter drier) (2) removes any moisture (water vapor) or dirt that may be carried by the liquid refrigerant.
4. The liquid indicator (sight glass) (3) indicates the presence of moisture and quantity of refrigerant in the system.
5. The thermostatic valve (5) controls the amount and pressure of liquid refrigerant to the evaporator coil (6). The thermostatic valve senses the temperature and pressure of the refrigerant as it leaves the evaporator coil.
6. As the liquid refrigerant leaves the thermostatic valve (5) it enters the evaporator coil (6). As the liquid enters the coil at a reduced pressure, the reduction in pressure and the warmer air being forced across the tubes of the coil cause the refrigerant to boil and change to a gas (vapor). The evaporator blower circulates the warm air from the conditioned space over and through the evaporator coil. Refrigerant absorbs heat when it changes from a liquid to a gas. As the air from the conditioned spaces comes in contact with evaporator coil (6), the air is cooled.

HEATING CYCLE

When the MODE SELECTOR SWITCH is set for HI HEAT, all six heating elements, located behind the evaporator coil, are energized. These elements are protected from overheating by a thermal cutout switch. The TEMPERATURE CONTROL thermostatically controls the elements. When set for LOW HEAT, only three elements are energized.

Chapter 2

OPERATOR

24,000 BTUH, SPLIT PACK ENVIRONMENTAL CONTROL UNIT (ECU)

NSN 4120-01-516-4715 F24H4-2

CHAPTER 2
OPERATOR
OPERATING INSTRUCTIONS

WORK PACKAGE INDEX

<u>Title</u>	<u>WP Sequence No.</u>
DESCRIPTION AND USE OF OPERATOR'S CONTROLS AND INDICATORS	0004 00
OPERATION UNDER USUAL CONDITIONS	0005 00
OPERATION UNDER UNUSUAL CONDITIONS	0006 00

OPERATOR

24,000 BTUH, SPLIT PACK ENVIRONMENTAL CONTROL UNIT (ECU)

NSN 4120-01-516-4715 F24H4-2

DESCRIPTION AND USE OF OPERATOR'S CONTROLS AND INDICATORS

0004 00

GENERAL

The Environmental Control Unit is designed for a variety of installations and for operation under a wide range of climatic conditions. It is also designed for continuous or intermittent operation as a self-contained unit or may be connected to external filtering equipment for operation under Nuclear-biological-chemical (NBC) environmental conditions. Operators must be aware of any peculiarities or operational limitations for their specific installation. See the appropriate shelter manual for instructions peculiar to your specific installation.

OPERATOR'S CONTROLS AND INDICATORS

CAUTION

Do not operate the Environmental Control Unit in the COOL mode if the Refrigerant R-410A color has reached the yellow band or if numerous bubbles appear in the sight glass. COOL mode operation may be continued with the Refrigerant R-410A color in the chartreuse band or with only an occasional bubble appearing in the window, but the sight glass should be rechecked after each four hours of operation to ensure that the condition has not become worse.

1. The High Pressure Cutout Reset (1) is used to manually reset over pressure of Condenser compressor.
2. The Temperature Control knob (2) is adjusted to determine the level of warm or cold air produced.
3. Indicator lamps (3) located on the Remote Control Unit (5) and the refrigerant sight glass (6) located on the Condenser (7) are the only visual indicators incorporated in the Model F24H4-2 Environmental Control Unit.
4. The Mode Selection knob (4) is adjusted to apply unit power and determine the heat or cooling mode of operation.

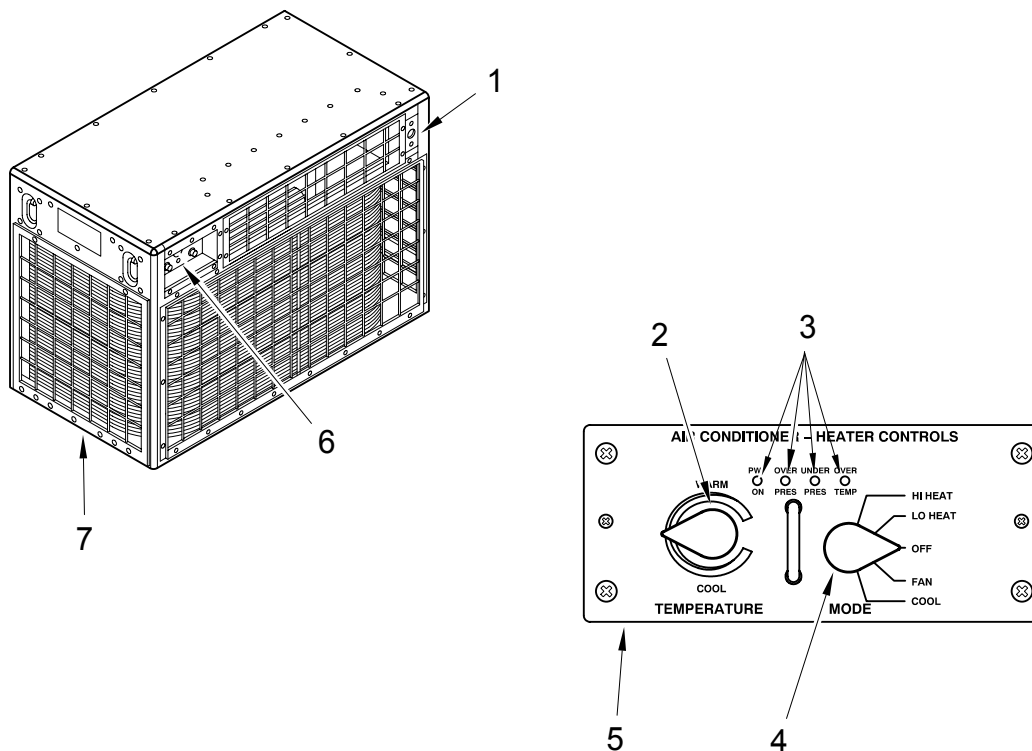

Figure 1. OPERATOR CONTROLS AND INDICATORS.

5. The sight glass (6) located on the Condenser Unit (7), is a port or window through which the refrigerant condition can be seen. Liquid refrigerant actually flows through the sight glass chamber only during cooling cycles when the Environmental Control Unit is in operation in the COOL mode. The sight glass is equipped with a center indicator that is moisture sensitive. Dry refrigerant is indicated by green. It turns to chartreuse when the moisture content becomes undesirable and to yellow when the level becomes unacceptable. Excessive moisture in the refrigerant may damage or possibly destroy the compressor. If the liquid refrigerant observed in the sight glass has an opaque, milky appearance, or frequent bubbles appear, the volume of refrigerant is low and the system should be charged. Either moisture or low charge indications should be reported to direct support maintenance.

END OF WORK PACKAGE

OPERATOR

24,000 BTUH, SPLIT PACK ENVIRONMENTAL CONTROL UNIT (ECU)

NSN 4120-01-516-4715
F24H4-2

OPERATION UNDER USUAL CONDITIONS

0005 00

INSTALLATION SITE PREPARATION

NOTE

Environmental Control Unit schematic diagrams do not depict shelter electrical connectors. Evaporator Main Power connector (J1) and Remote Control connector (J2) connect to vehicle shelter Main Power cable connector (J8) and Remote Control cable connector (J7). Remote Control Unit connector (P2) connects to vehicle shelter Remote Control cable connector (J14).

If the Environmental Control Unit is to be used on a shelter or system that is specifically designed to accept the Environmental Control Unit, see the Technical Manual(s) for that shelter or system. The following is a list of general guidelines for installation site preparation.

1. A relatively level surface capable of bearing the weight of the Environmental Control Unit to ensure proper condensate drainage. The surface should be level to within 10° from front to back and side to side. See the following three figures for mounting dimensions.
2. An unobstructed flow of air from outside the conditioned area to the ambient air inlet and discharge openings of the rear of the condenser assembly.
3. An unobstructed flow of air to and from inside the conditioned area to the return air inlet and the two supply air outlets located on the front of the evaporator assembly.

NOTE

A return air filter is not provided as part of the Environmental Control Unit. It must be installed in ductwork connected to the return air inlet.

4. An unobstructed flow of air from outside the conditioned area to the fresh air intake.

NOTE

The fresh air intake may be mounted on the left or right side of the evaporator assembly by exchanging it with either fresh air cover plate.

5. Access to all removable outside covers should be considered for servicing internal parts.

WARNING

Check that no source of dangerous or objectionable fumes is near the fresh air intake.



6. A source of 208 volt, 3 phase, 400 hertz input power rated at 30 amps. The power source outlet should be located as near as possible to the installed location of the Environmental Control Unit. The power source wiring must include a disconnect switch. However, provisions should be made to ensure that power is not disconnected during normal operation and the disconnect is not used to turn off the Environmental Control Unit for normal shutdown.

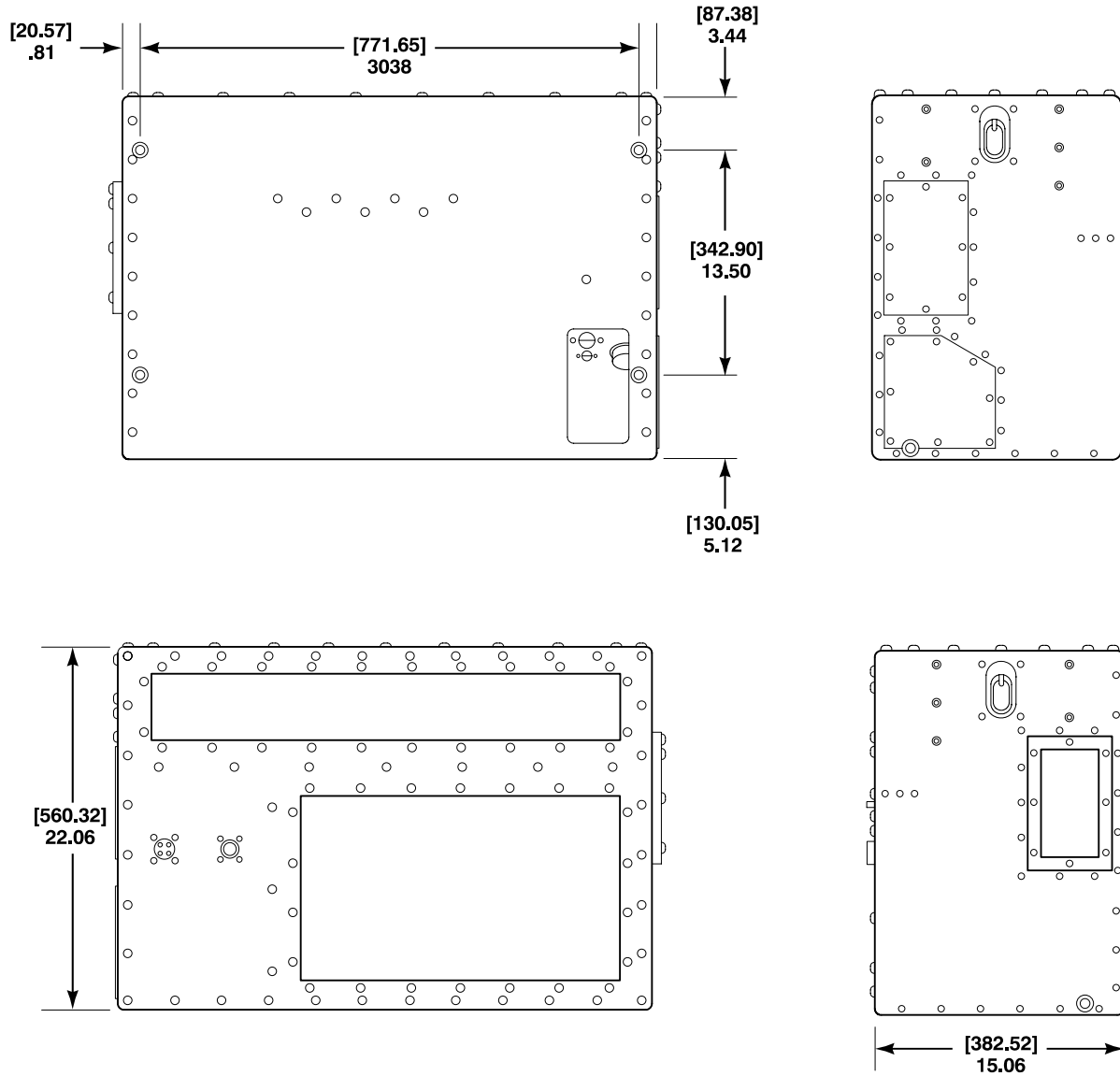

Figure 1. EVAPORATOR ASSEMBLY INSTALLATION DIMENSIONS.

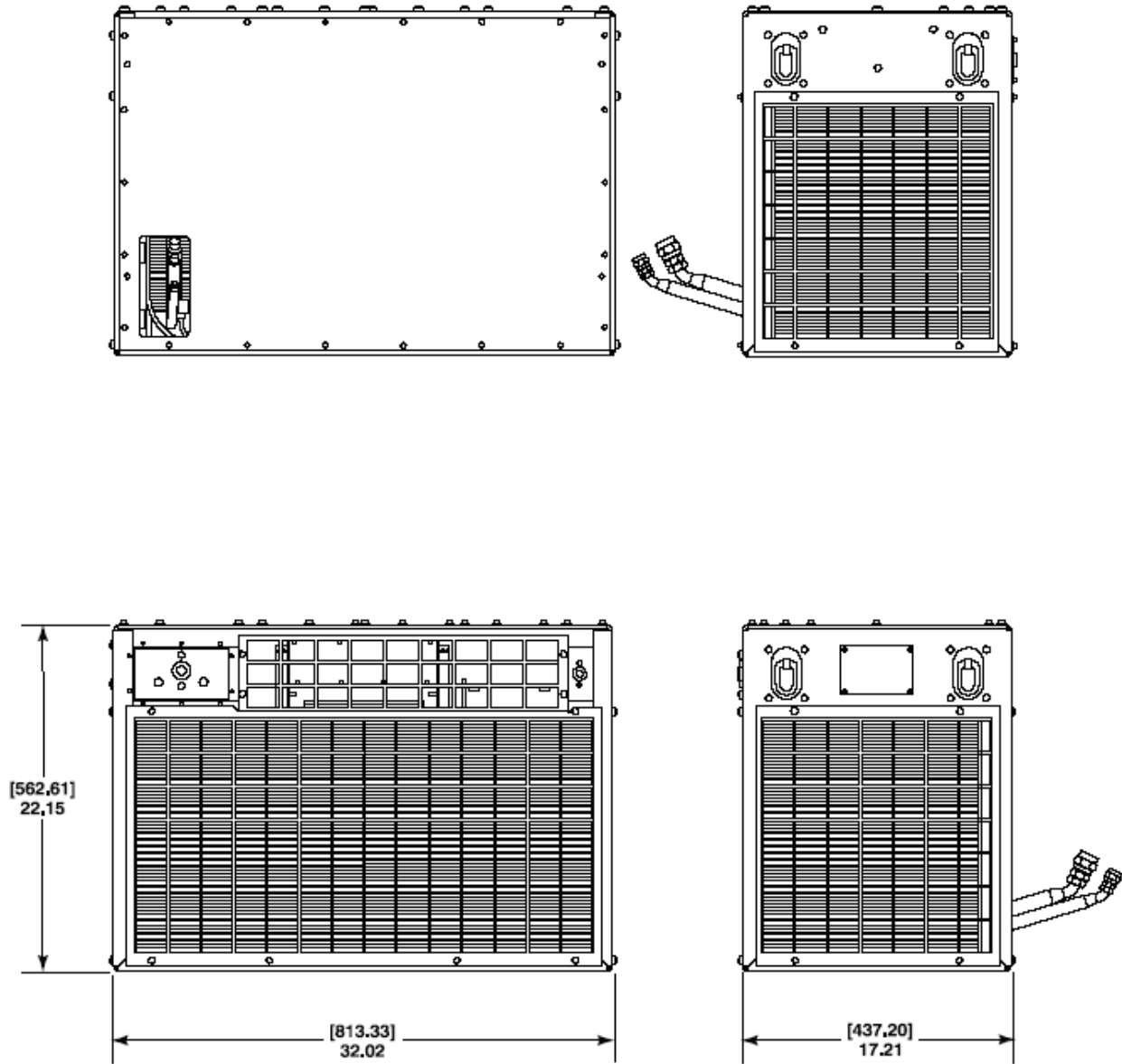

Figure 2. CONDENSER ASSEMBLY INSTALLATION DIMENSIONS.

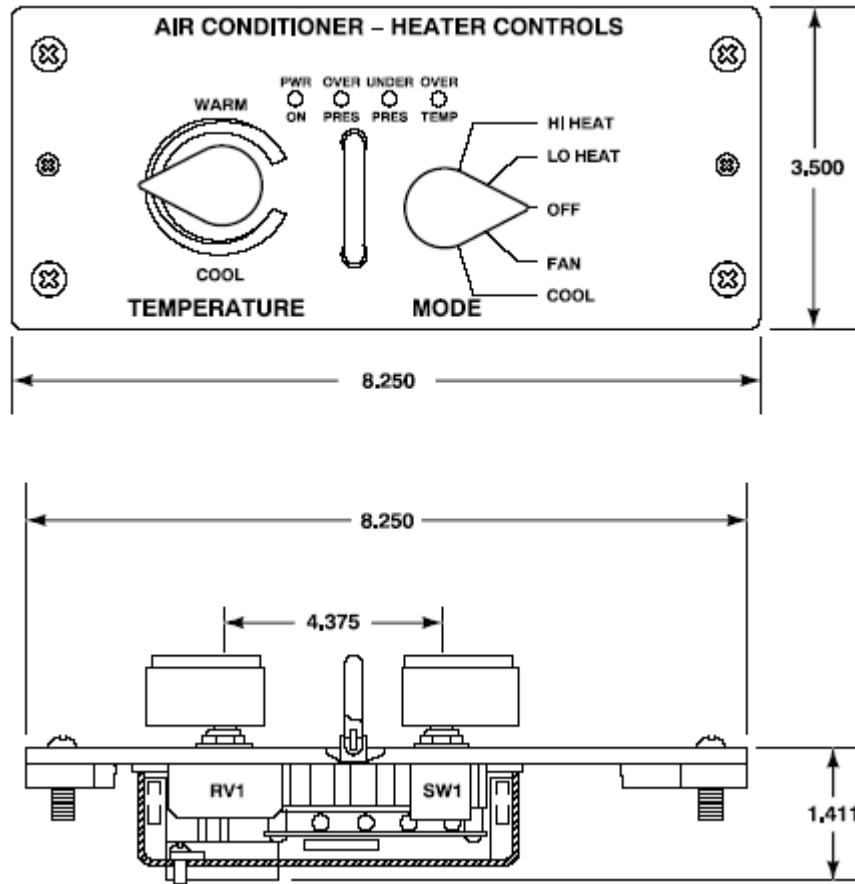

Figure 3. REMOTE CONTROL UNIT INSTALLATION DIMENSIONS.

SHELTER REQUIREMENTS**NOTE**

Environmental Control Unit schematic diagrams do not depict shelter electrical connectors. Evaporator Main Power connector (J1) and Remote Control connector (J2) connect to vehicle shelter Main Power cable connector (J8) and Remote Control cable connector (J7) . Remote Control Unit connector (P2) connects to vehicle shelter Remote Control cable connector (J14).

The following items are not provided as part of the environmental control unit. They are part of the shelter and are necessary for environmental control unit installation and operation. Figure 4

1. Remote Control Cable (1).
2. A power input cable (2) supplying 208 vac at 400 hertz.
3. Installation hardware and grounding strap. The Patriot installation uses the following:
 - 16 each Flat Washers (5)
 - 16 each Resilient Mounts (6)
 - 8 each Flat Washers (7)
 - 4 each Screws (8)
 - 4 each Grounding Straps (9)
 - 4 each Lock Washers (10)
 - 4 each Locking Nuts (11)
 - 8 each Hex Head Screws (12)

NOTE

The fresh air intake duct may be mounted on the left or right side of the Environmental Control Unit by exchanging it with one of the two fresh air cover plates.

4. Shelter air ducts connect to fresh air duct (3). Condensate drain items may be required. If condensate drain water from the port(s) (4) located in the lower side panels of the evaporator assembly casing is objectionable, or creates a hazard, it must be piped to a safe disposal location. The environmental control unit is equipped with two drain connections. The environmental control unit is shipped from the factory with both of these ports plugged. The plugs must be removed prior to operation.

PREPARATION FOR MOVEMENT

1. Turn power to Environmental Control Unit off at shelter main circuit breaker.
2. Disconnect power cable and remote control cable to Environmental Control Unit at access panel (cable penetration point on shelter).
3. Remove rain shield from around Environmental Control Unit to shelter joint. (See Shelter Manual).
4. Remove the fresh air duct (8) and fresh air EMI screens (1) and (2). Figure 7
5. Disconnect condensate drain lines from Environmental Control Unit, if applicable.
6. Remove hex head screws, flat washers, and resilient mounts from the underside of the Environmental Control Unit mounting shelf.

WARNING



Do not allow anyone under equipment suspended from a lifting device. Do not allow the unit to swing while suspended from a lifting device. Failure to observe this warning may result in injury to personnel and damage to the equipment.

CAUTION

During lifting procedures, take care that shock mounts are not damaged.

7. Position lifting device so that lifting hook (1) is centered over Environmental Control Unit. Figure 5

CAUTION

During lifting operations, insure a guide rope is attached to the ECU to control swing of the unit while suspended by a hoist.

8. Connect sling to the four outside corners (2) Environmental Control Unit lifting rings and the lifting equipment. Figure 5

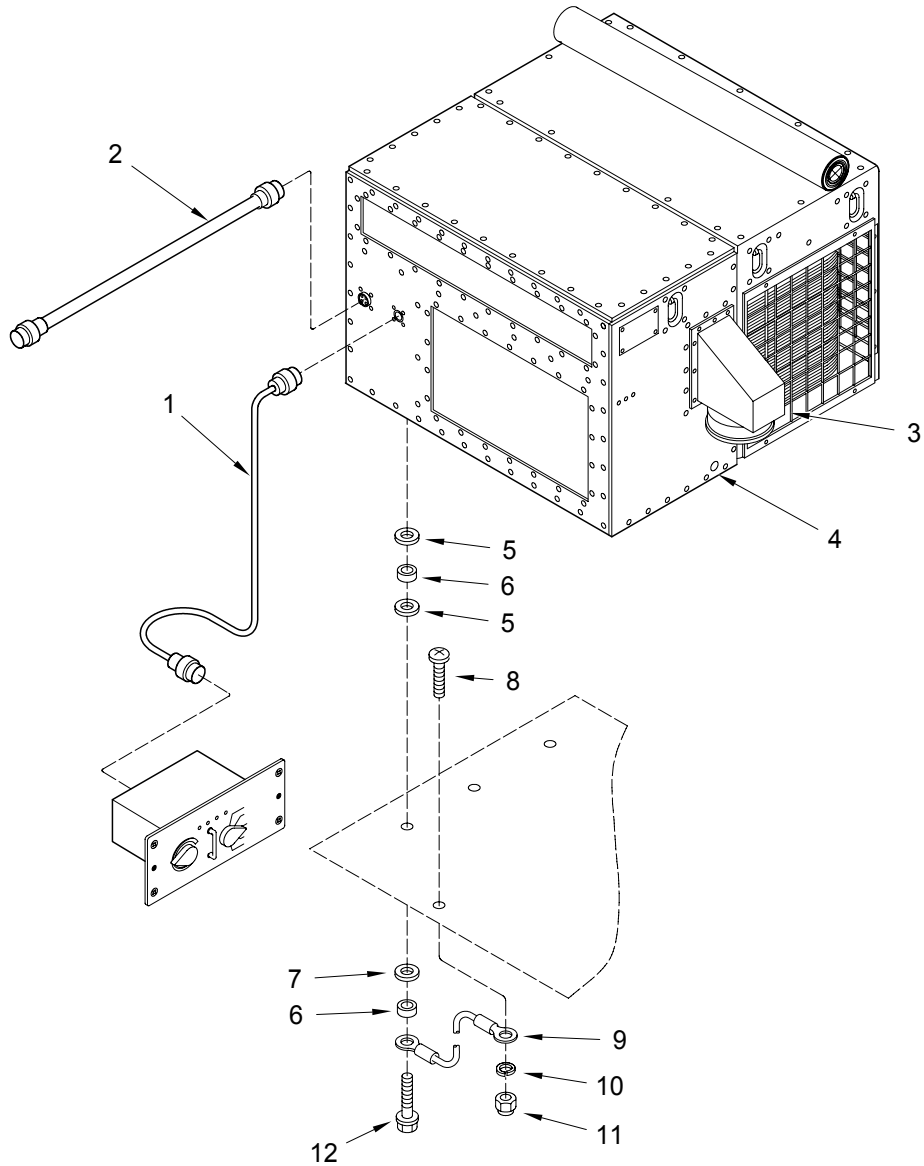

Figure 4. GENERAL INSTALLATION ITEMS.

9. Take care that mounting hardware and resilient mounts, between Environmental Control Unit and mounting shelf, are not damaged or lost. Lift the Environmental Control Unit slightly, and carefully move it away from shelter adapter enough to allow space to disconnect power cable and remote control cable.
10. Disconnect power cable J1 (7) and remote control cable J2 (6) from the front of the Environmental Control Unit. Do not remove cables from shelter access panel. Figure 7

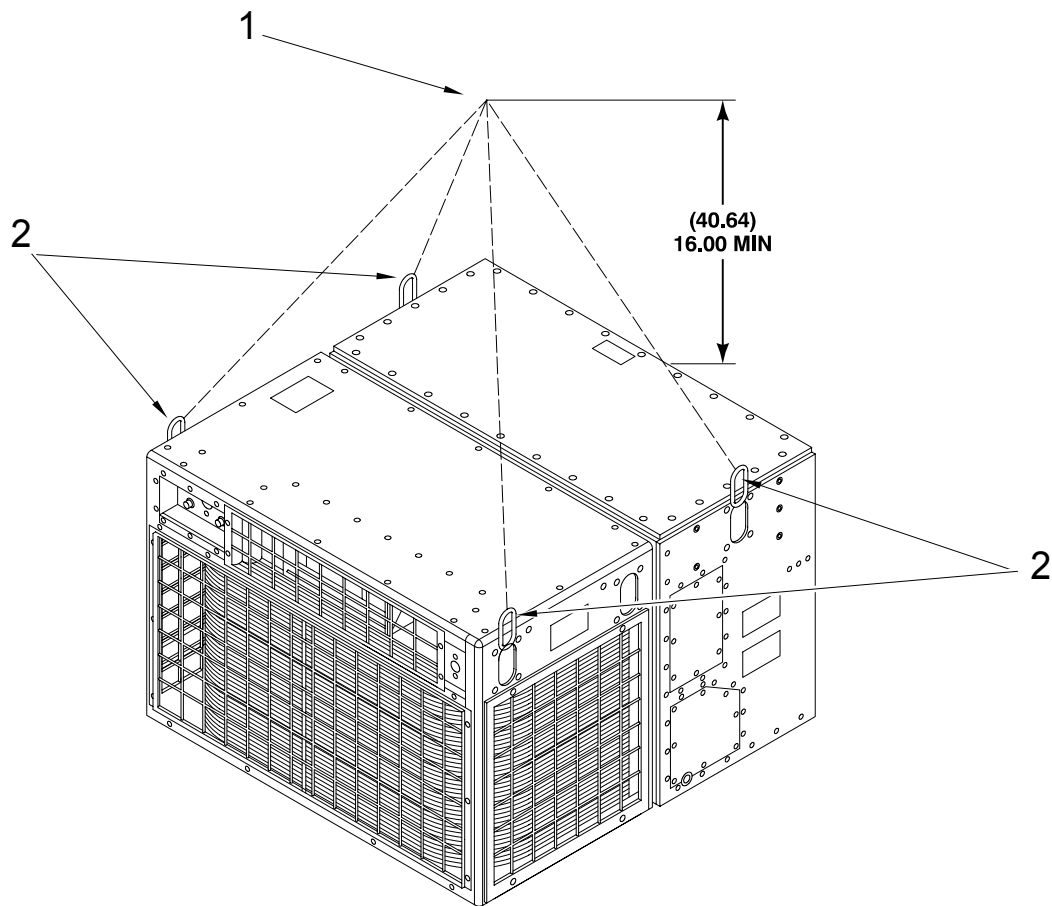

Figure 5. HOISTING INFORMATION.

WARNING

The ECU weighs in excess of 300 pounds. Do not allow anyone under equipment suspended from a lifting device. Do not allow the unit to swing while suspended from a lifting device. Failure to observe this warning may result in injury to personnel and damage to the equipment.

CAUTION

Use care in handling to avoid damage to the Environmental Control Unit. If an overhead lifting device must be used, use an appropriate sling so that the weight of the unit is borne by the base of the shipping container.

11. Lift the Environmental Control Unit off of the mounting shelf and place on transport carrier or on ground.
12. Disconnect sling from Environmental Control Unit. Remove mounting hardware and resilient mounts from mounting shelf and retain for reuse, if they are in good condition.

NOTE

Normally it is not necessary to remove the remote control assembly. When necessary remove the remote control assembly from the inside of the shelter by loosening the four captive screws and disconnecting the remote control cable.

ASSEMBLY AND PREPARATION FOR USE**NOTE**

The Environmental Control Unit is packaged in a container designed for shipment and handling with the cabinet in an upright position. The base of the container is constructed as a shipping pallet with provisions for the insertion of the forks on materials handling equipment.

UNPACKING

1. General. Normally, the Environmental Control Unit should be moved into the immediate area in which it is to be installed before it is unpacked.
2. Remove all blocking and tiedowns that may have been used to secure the container to the carrier.
3. Use a forklift truck, overhead hoist, wrecker, or other suitable material handling equipment to remove the packaged unit from the carrier

NOTE

The shipping container and pallet are of such a design that they may be retained for reuse for mobility purposes if frequent relocation of the Environmental Control Unit is anticipated.

4. Remove Shipping Container. Remove all bands and retaining devices that secure the upper container to the base pallet. Lift the container vertically and remove it from the base pallet.
5. Remove Packaging. Remove the cushioning around the top of the cabinet and retain if reuse is anticipated. Remove the preservation barrier, if applicable, by tearing around the bottom of the Environmental Control Unit cabinet. Remove the technical publications envelope and accessory sack that are taped to the cabinet, and put them in a safe place.

NOTE

It is recommended that the cabinet be left bolted to the shipping pallet until time to place it in the installation position. All receiving inspection actions can be conducted without removal from the pallet.

6. See that all packing material and shipping pallet have been removed from the Environmental Control Unit and remote control panel. Remove drain plugs or tape. Retain drain plugs for use in NBC operations.

NOTE

The unit weight (less shipping pallet) is 320 pounds (145.3 kg). When lifting or moving the unit on the shipping pallet, a forklift, or overhead lifting device may be used. When removing the unit from the shipping pallet, or lifting the unit into position, an overhead lifting device must be used.

7. See "INSTALLATION SITE PREPARATION" and "SHELTER REQUIREMENTS" earlier in this work package for general information pertaining to site preparation and additional items required for installation that are not provided with the Environmental Control Unit.
8. Check to see that power cable and remote control cable have been inserted through the Environmental Control Unit to shelter access panel. Place them so that they will not be damaged when the Environmental Control Unit is lifted into position.
9. Check to see that power to Environmental Control Unit power cable has been turned off/disconnected at the main shelter circuit breaker.
10. Remove the fresh air duct.
11. Align mounting hardware that is used between Environmental Control Unit and mounting shelf with slotted mounting holes. Loosely tape in place toward the front of the slotted holes.
12. Position lifting device so that lifting hook (1) is centered over Environmental Control Unit. See Figure 4

WARNING

The ECU weighs in excess of 300 pounds. Do not allow anyone under equipment suspended from a lifting device. Do not allow the unit to swing while suspended from a lifting device. Failure to observe this warning may result in injury to personnel and damage to the equipment.

WARNING

During lifting operations, the mechanic(s) must be visible to the lifting device operator and in a position to physically guide the Environmental Control Unit as it is lifted into position.

CAUTION

During lifting procedures, take care that shock mounts are not damaged.

13. Connect sling to the four outside corners (2) Environmental Control Unit lifting rings and the lifting device. See Figure 4.
14. Carefully lift the Environmental Control Unit into position over the mounting shelf approximately 5 to 6 inches (12.7 to 15.2 cm) away from Environmental Control Unit adapter opening.
15. Connect power cable to connectors J1 (7) and remote control cable J2 (6) on front of Environmental Control Unit. See Figure 7. Slowly lower air conditioner into position, align and loosely attach remaining installation hardware.
16. With the Environmental Control Unit slightly supported by lifting device, push air conditioner firmly toward shelter to compress weather seal. At the same time, release tension on lifting device and secure the installation hardware.
17. Remove sling attachments from Environmental Control Unit and move lifting device out of the way.
18. Install the rain shield around the Environmental Control Unit to shelter joint. (See Shelter Manual)
19. Install the fresh air duct (8). See Figure 7.
20. Connect all drain lines or hoses, if applicable.

WARNING

Ensure Remote Control Unit mode selector knob is in the "OFF" position prior to connecting.

21. Check to see that power cable and remote control cable are connected at shelter access panel.
22. Install the remote control assembly in the shelter if removed.
23. Separate receptacle and plug. Mate plug with receptacle on rear of control box. Isolate and store receptacle.

24. Complete installation of control box assembly in shelter utilizing existing fasteners.

CAUTION

Under normal operating conditions, before starting the Environmental Control Unit in any mode, make sure that all screens and guards are in place and unobstructed. If there is a loud banging noise coming from the condenser section when the unit is operated in the COOL mode, immediately turn the MODE SELECTOR SWITCH to OFF. Allow at least one hour of time to elapse before attempting a restart in the COOL mode.

25. Turn power to Environmental Control Unit on at shelter circuit breaker.
26. Check Environmental Control Unit operation in all modes. (See WP 0005 00)

INITIAL ADJUSTMENTS, BEFORE USE AND SELF TEST

1. Check to see that the POWER ON INDICATOR LAMP illuminates when power is connected to the unit and an operation MODE is selected. See Figure 6.

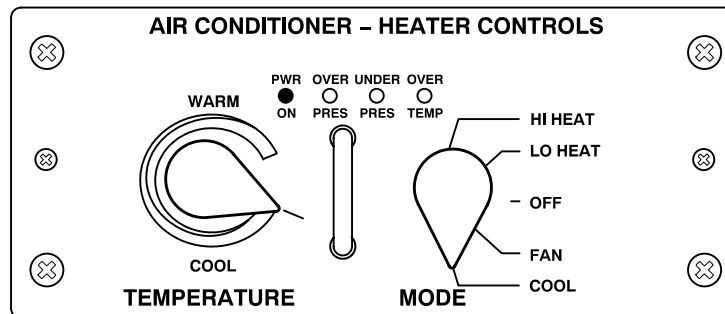

Figure 6. POWER ON INDICATOR LAMP

2. Check that all air intake (1) and discharge openings (2) are clear. See Figure 7.
3. Condensate drains (3) must not be plugged. Assure that both drains are either open or piped to a satisfactory location with a proper drain system. See Figure 7.

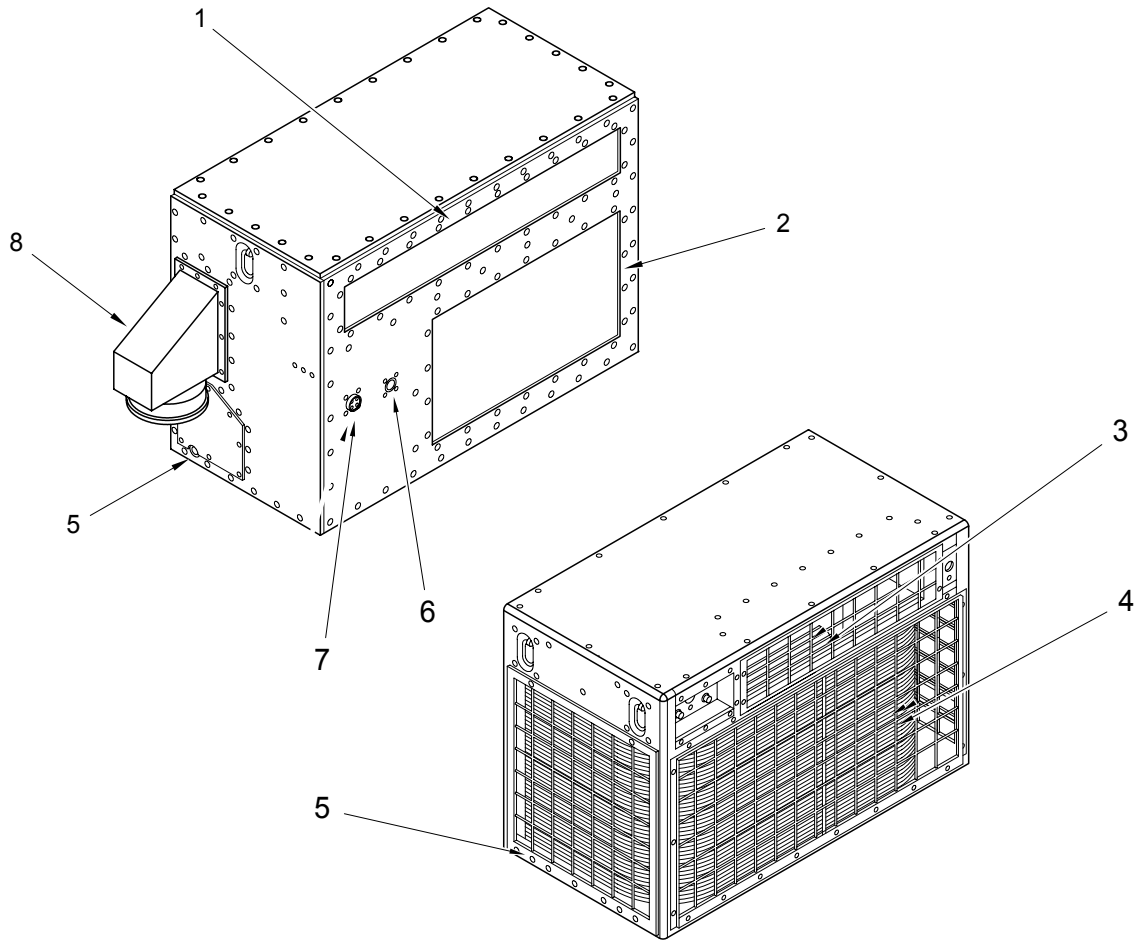

Figure 7. INTAKE AND DISCHARGE OPENINGS AND DRAINS.

OPERATING PROCEDURES

OPERATION IN COOL MODE

1. Turn MODE SELECTOR SWITCH to COOL. After 5 seconds, airflow can be felt at the conditioned air outlets inside the shelter.

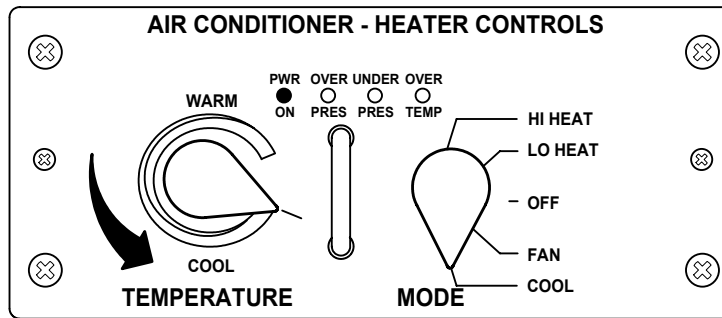

Figure 8. OPERATION IN COOL MODE.

2. Turn TEMPERATURE CONTROL towards COOL. After 2 minutes, air from conditioned air outlets inside the shelter will feel cooler than ambient air.

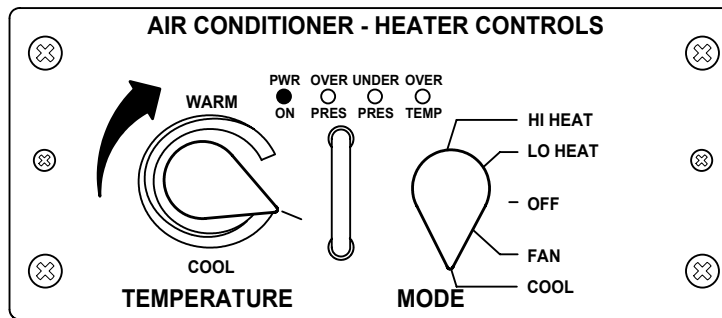

Figure 9. ADJUSTMENT - COOL (COOL MODE).

3. When the room or shelter temperature drops to the desired level, slowly turn the TEMPERATURE CONTROL knob towards WARM. Cooling will stop when you reach the approximate room temperature.

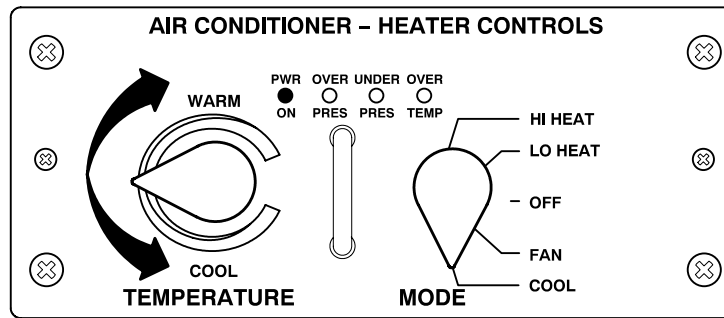

Figure 10. ADJUSTMENT - WARM (COOL MODE).

4. Further adjustment can be made by turning the TEMPERATURE CONTROL knob slightly toward the WARM or COOL setting until a constant desired room or shelter temperature is maintained.

OPERATION IN THE LO HEAT MODE

1. Turn MODE SELECTOR SWITCH to LO HEAT. After 5 seconds, airflow can be felt.

NOTE

In the LO HEAT mode, the condenser (rear) section blower does not operate.

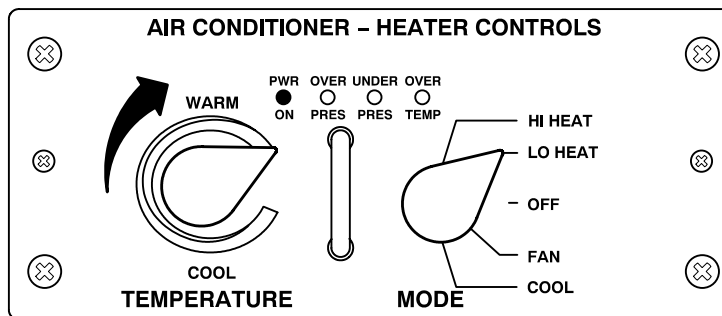

Figure 11. OPERATION IN LO HEAT MODE.

2. Turn TEMPERATURE CONTROL knob towards WARM. After 2 minutes, air from conditioned air outlets will feel warmer than the ambient air.

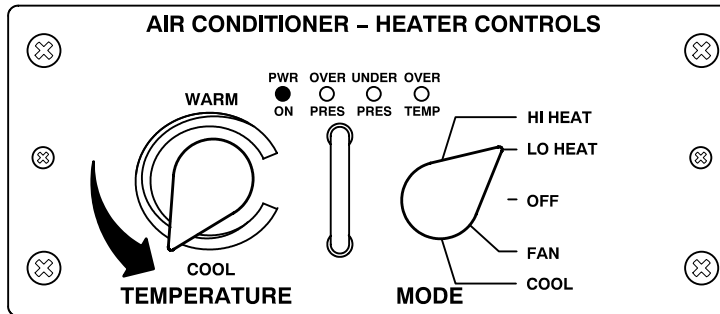

Figure 12. ADJUSTMENT - WARM (LO HEAT MODE).

3. When the room or shelter air temperature rises to the desired level, slowly turn the TEMPERATURE CONTROL knob towards COOL. Heating will stop when you reach the approximate room temperature.

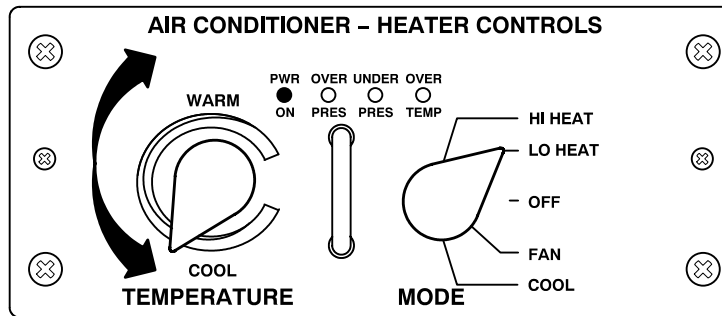

Figure 13. ADJUSTMENT - COOL (LO HEAT MODE).

4. Further adjustment can be made by turning the TEMPERATURE CONTROL knob slightly towards the WARM or COOL setting until a constant desired room or shelter temperature is maintained.

OPERATION IN THE HI HEAT MODE

NOTE

Use HI HEAT mode when LO HEAT mode fails to heat room or shelter, or for faster warm up after a period of shutdown.

1. Turn MODE SELECTOR SWITCH to HI HEAT. After 5 seconds, airflow can be felt.

NOTE

In the HI HEAT mode, the condenser (rear) section blower does not operate.

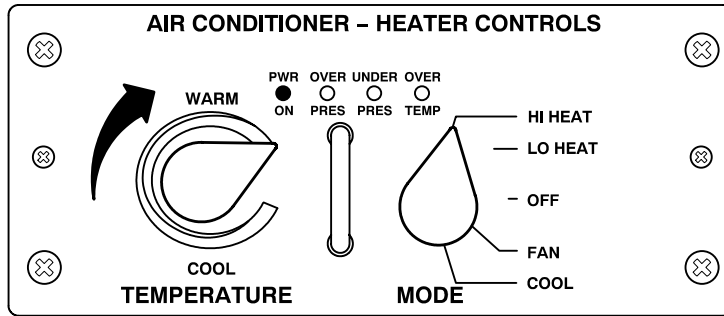

Figure 14. OPERATION IN THE HI HEAT MODE.

2. Turn TEMPERATURE CONTROL knob towards WARM. After 2 minutes, air from conditioned air outlets will feel warmer than the ambient air.

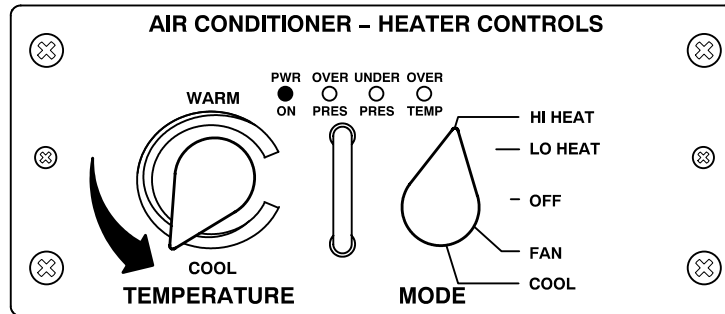

Figure 15. ADJUSTMENT - WARM (HI HEAT MODE).

3. When the room or shelter air temperature rises to the desired level, slowly turn the TEMPERATURE CONTROL knob towards COOL.

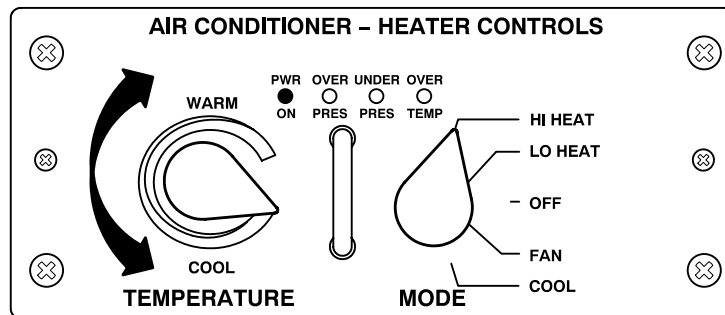

Figure 16. ADJUSTMENT - COOL (HI HEAT MODE).

NOTE

During LO HEAT mode operation, one bank of three heating elements operates. Three additional elements operate when the HI HEAT mode of operation is selected. The TEMPERATURE CONTROL will control the range of heat supplied for each bank(s) selected by the mode selection knob.

4. Turn the TEMPERATURE CONTROL knob slightly towards the WARM or COOL setting until a constant desired room or shelter temperature is maintained.

OPERATING THE UNIT FOR VENTILATION ONLY (No heating or cooling desired.)

1. Turn the MODE SELECTOR SWITCH to the FAN position.
2. Turn the TEMPERATURE CONTROL as far as it will go towards the COOL position.

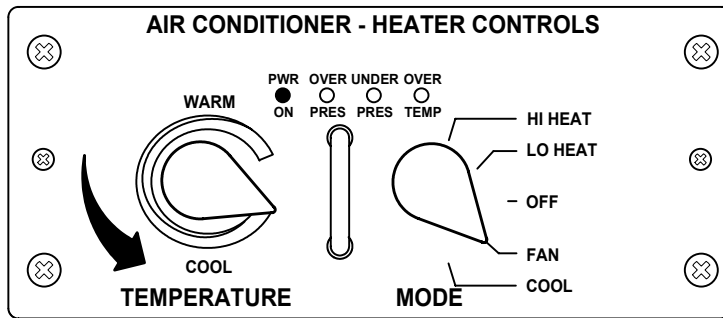

Figure 17. VENTILATION ONLY.

SHUTDOWN

1. Turn the MODE SELECTOR SWITCH to OFF

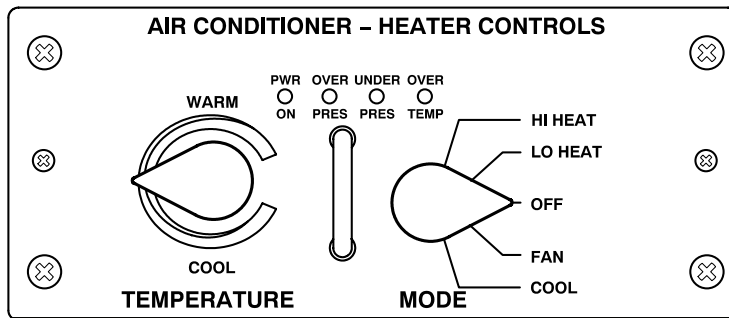

Figure 18. OFF (SHUTDOWN).

OPERATOR

24,000 BTUH, SPLIT PACK ENVIRONMENTAL CONTROL UNIT (ECU)

**NSN 4120-01-516-4715
F24H4-2**

OPERATION UNDER UNUSUAL CONDITIONS

0006 00

There are no special instructions for operation under unusual conditions. The operator should, however, be aware of the following general practice type suggestions.

UNUSUAL ENVIRONMENT AND WEATHER

The following will apply to all extreme weather conditions.

- Keep all doors and other openings in the room or shelter tightly closed when not in use.
- Limit traffic in and out of doors as much as possible.
- Under extreme cold climatic conditions, such as blowing snow, or freezing rain, which might enter, and damage condenser section, the unit may be operated in the LO HEAT or HI HEAT mode.
- Frequency of maintenance must also be increased for most extreme weather conditions. This is the responsibility of field maintenance at the organizational level.

INTERIM NUCLEAR, BIOLOGICAL, AND CHEMICAL (NBC) DECONTAMINATION PROCEDURES

In the presence of NBC agents, the using unit conducts decontamination as soon as possible. The decision to perform hasty or deliberate decontamination will depend on the situation, the extent of contamination, decontamination resources, and the mission. Only that which is necessary to accomplish the mission is decontaminated.

NOTE

Install drain plugs in drain holes located on each side of evaporator assembly. Roll cover down over condenser grille. Insure seams along each edge are sealed using hook and loop fasteners.

END OF WORK PACKAGE

Chapter 3

OPERATOR

24,000 BTUH, SPLIT PACK ENVIRONMENTAL CONTROL UNIT (ECU)

NSN 4120-01-516-4715

F24H4-2

CHAPTER 3
FIELD LEVEL
TROUBLESHOOTING PROCEDURES

WORK PACKAGE INDEX

<u>Title</u>	<u>WP Sequence No.</u>
TROUBLESHOOTING PROCEDURES	0007 00
OPERATIONAL CHECKOUT AND TROUBLESHOOTING PROCEDURES	0008 00

FIELD LEVEL

24,000 BTUH, SPLIT PACK ENVIRONMENTAL CONTROL UNIT (ECU)

NSN 4120-01-516-4715
F24H4-2

MALFUNCTION/SYMPTOM INDEX

0007 00

INTRODUCTION

1. This table lists the common malfunctions that you may find with your equipment. Perform the tests, inspections, and corrective actions in the order they appear in the table.
2. This table cannot list all the malfunctions that may occur, all the tests and inspections needed to find the fault, or all the corrective actions needed to correct the fault. If the equipment malfunction is not listed or actions listed do not correct the fault, notify your supervisor.
3. Troubleshooting by the operator is limited to checking operation of the environmental control unit. Any failure in performance or suspected problem should be reported to field and/or sustainment level maintenance.
4. The malfunction/symptom index is a quick reference index for finding troubleshooting procedures. Associated with each symptom name is a work package sequence number representing the starting point in a troubleshooting sequence. Should any one symptom require more than one troubleshooting sequence to arrive at the most likely area of investigation, the additional starting point numbers are presented.
5. As the troubleshooting activity progresses through to the conclusion of a particular sequence, a reference is made to the next logical troubleshooting sequence by work package sequence number. This type of activity continues until successful fault isolation is achieved.

TROUBLESHOOTING PROCEDURES INDEX

<u>Malfunction</u>	<u>WP / Page No.</u>
1. Environmental Control Unit will not start in any mode	0008 00-2
2. No Cooling - No indicator lamp illuminated	0008 00-5
3. Over pressure and under pressure lamps are illuminate in cool mode	0008 00-10
4. Insufficient heating, no indicator lamp illuminates	0008 00-11
5. Insufficient heat with over temperature lamp illuminated	0008 00-12
6. Over pressure indicator lamp illuminated	0008 00-14
7. Under pressure indicator lamp illuminated	0008 00-15

END OF WORK PACKAGE

FIELD LEVEL

24,000 BTUH, SPLIT PACK ENVIRONMENTAL CONTROL UNIT (ECU)

NSN 4120-01-516-4715
F24H4-2

OPERATIONAL CHECKOUT AND TROUBLESHOOTING PROCEDURES

0008 00

INITIAL SETUP:

Equipment Condition

ECU installed in shelter. See WP 0005 00,
INSTALLATION SITE PREPARATION

Personnel Required

Field level technician (2)

Reference

TM9-4120-429-24P
WP 0005, OPERATING PROCEDURES

Tools And Special Tools

Tool Kit, Refrigeration Ordnance
5180-00-5961474

Multimeter (1)

WARNING



Remove electrical power when performing work inside of equipment that does not require the use of power for the procedure being performed. Use extreme care when performing procedures requiring application of power to the equipment.

NOTE

Where indicated, remove the environmental control unit from the shelter. Configure the unit for troubleshooting and/or testing. Where necessary, the ECU should be connected to a main power source with proper voltages applied and remote control unit. (See WP 0005 00, INSTALLATION SITE PREPARATION). Refer to the applicable work package for reassembly after maintenance service.

NOTE

Preferred repair methods consist of replacing wires terminals, connectors, etc., rather than splicing wires, bending ends to form terminals, and other makeshift procedures; although the latter may be appropriate for emergency field repairs. For all troubleshooting and wire repairs, refer to the Wire List (WP 0039 00) and to the Wiring Diagram (WP 0046 00, Figure 1).

NOTE

Environmental Control Unit schematic diagrams do not depict shelter electrical connectors. Evaporator Main Power connector (J1) and Remote Control connector (J2) connect to vehicle shelter Main Power cable connector (J8) and Remote Control cable connector (J7) . Remote Control Unit connector (P2) connects to vehicle shelter Remote Control cable connector (J14).

NOTE

Perform Operating Procedures in WP 0005 00 after faults have been corrected.

FAULT PROCEDURE 1 - ENVIRONMENTAL CONTROL UNIT WILL NOT START IN ANY MODE**SYMPTOM**

Environmental Control Unit will not start when mode selector knob is engaged.

INDICATION/CONDITION

Power "ON" indicator lamp illuminates in "FAN" mode.

CORRECTIVE ACTION

Replace Remote Control Unit

STEP**INDICATION/CONDITION**

Power "ON" indicator lamp fails to illuminate when mode selector knob is engaged.

INDICATION/CONDITION

No power to Environmental Control Unit.

WARNING

Disengage shelter circuit breaker prior to handling power cable

CORRECTIVE ACTION

1. **Check main power connections.**
 - Inspect power cable for cuts or burns.
 - Check 208 VAC, 3 phase, 400 hertz main power cable connection
 - Inspect Remote Control Unit Cable for cuts or burns
 - Check Remote Control Unit cable connections

FAULT PROCEDURE 1 - ENVIRONMENTAL CONTROL UNIT WILL NOT START IN ANY MODE (Con't)

- a. Repair or replace main power cable if damaged.
- b. Connect main power cable if loose.
- c. Connect Remote Control Unit cable if loose.

STEP**INDICATION/CONDITION**

Evaporator internal circuit breaker, CB1 (1) engages when main power is applied. Figure 1

MALFUNCTION

Faulty Circuit Card Assembly

CORRECTIVE ACTION

1. If circuit breaker, CB1 engages, observe circuit card assembly for LED illumination.
2. If LED(s) illuminate, replace circuit card assembly.
3. If LED(s) fail to illuminate, refer to WP 0017 00.

STEP**INDICATION/CONDITION**

Circuit breaker CB1 (1) fails to engage. Figure 1

CORRECTIVE ACTION

1. Replace Circuit Breaker CB1
 - a. Remove air inlet cover located above the access cover from evaporator.
 - b. Remove screws securing CB1 from the exterior of the evaporator.
 - c. Remove CB1 through the air inlet opening.
 - d. Tag and remove wires from CB1.
 - e. Replace CB1 and install in reverse order listed in steps above.

FAULT PROCEDURE 1 - ENVIRONMENTAL CONTROL UNIT WILL NOT START IN ANY MODE (Con't)**EVAPORATOR ASSEMBLY**

Figure 1. CIRCUIT BREAKER, POWER AND REMOTE CONTROL UNIT CONNECTIONS.

STEP**INDICATION/CONDITION**

Evaporator fan fails to operate with power is applied and "FAN" mode selected.

CORRECTIVE ACTION

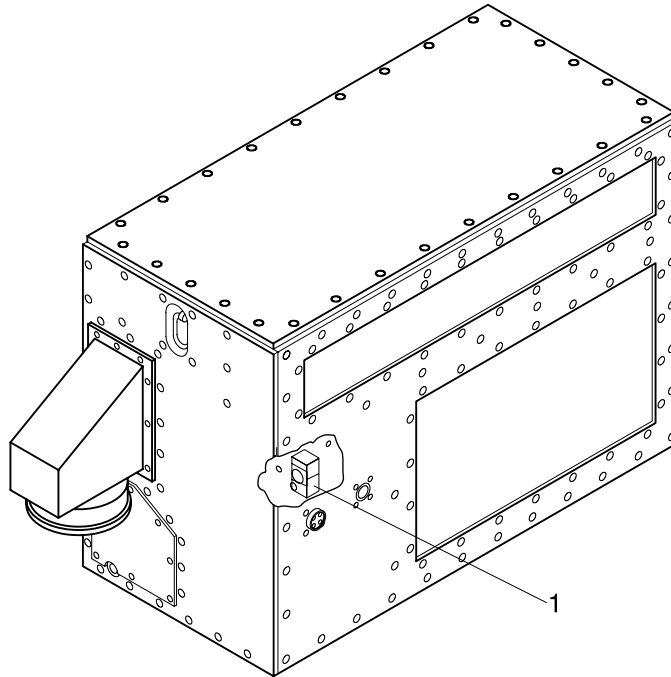
1. With power removed and "FAN" mode selected, check continuity on Remote Control Unit connector P2 between Pin E and Pin A. If there is no continuity, notify next higher level maintenance to replace Remote Control Unit.

FAULT PROCEDURE 1 - ENVIRONMENTAL CONTROL UNIT WILL NOT START IN ANY MODE (Con't)**STEP****INDICATION/CONDITION**

Fan fails to operate when power is applied and "FAN" mode selected.

CORRECTIVE ACTION

1. See WP0017 00, EVAPORATOR BLOWER AND MOTOR ASSEMBLY.

FAULT PROCEDURE 2 - NO COOLING - NO INDICATOR LAMP ILLUMINATED**SYMPTOM**

No cool air from ECU or indicator lamp illuminated when "COOL" mode selected.

STEP**INDICATION/CONDITION**

No cool air from ECU when "COOL" mode selected.

CORRECTIVE ACTION

1. Check Remote Control Unit settings.
 - a. Check that mode selector knob is in the "COOL" position.
 - b. Check that temperature control knob is adjusted for cooler setting.
2. Check Condenser Assembly covers.
 - a. Inspect condenser section for loose, damaged, or missing covers and screws.
 - b. Tighten loose screws.
 - c. Install missing covers and screws.
 - d. Repair or change damaged covers.
 - e. Check for airflow restrictions.

FAULT PROCEDURE 2 - NO COOLING - NO INDICATOR LAMP ILLUMINATED (Con't)

3. Check continuity.
 - a. With power removed and "COOL" mode selected, check continuity on Remote Control Unit connector P2 between Pin E and Pin H.
 - b. If continuity is not present, replace Remote Control Unit.
 - c. Measure for resistance of $5K \pm 10\%$ between Pin M and ground.
 - d. If resistance measured is incorrect or not present, replace Remote Control Unit. (See Wiring Diagram, WP 00 45 00)

STEP**INDICATION/CONDITION**

Relay K4 operation.

CORRECTIVE ACTION

1. Disconnect connector J6 from P6 (See WP 0045 00).
 - a. Check for nominal 208 VAC between pins 1 and 2, 1 and 3, and 2 and 3 on J6.
 - b. If 197 to 229 VAC is present in all three phases, replace relay K4.

STEP**INDICATION/CONDITION**

Out put Voltage, EMI filter FL1. (See WP 0021 00, EVAPORATOR HARNESS ASSEMBLIES).

CORRECTIVE ACTION

1. Disconnect connector J6 from P6 (See WP 0045 00).
 - a. Visually inspect EMI filter FL2 for damage to terminals or broken wiring.
 - b. Check for nominal 208 VAC between pins A and B, A and C, and B and C on load side of EMI filter FL1.
 - c. If 197 to 229 VAC is present in all three phases, replace circuit breaker CB1.
 - d. If inadequate or no voltage is present, replace EMI filter.

STEP**INDICATION/CONDITION**

Digital display on Variable Frequency Device indicates three dashes.

CORRECTIVE ACTION

1. Observe light emitting diode D23 on Circuit Card Assembly PC2 (See WP 0017 00).
2. If light emitting diode D23 is illuminated, replace Variable Frequency Device (See WP 0018 00, VARIABLE FREQUENCY DEVICE).
3. If light emitting diode D23 is not illuminated disconnect P108 from circuit card assembly PC2.
4. Measure resistance of 800 ohms to 30K ohms between pins 7 and 8 on P108.
 - a. If good, replace circuit card assembly PC2.
 - b. If infinite or short reading replace return air temperature sensor RV2.
5. Measure resistance of 800 ohms to 30K ohms between pins 9 and 10 on P108.
 - a. If good, replace circuit card assembly PC2.
 - b. If infinite or short reading replace evaporator coil temperature sensor TS1.

STEP**INDICATION/CONDITION**

Fault message "LF" displayed on the variable frequency device digital display. (See WP 0018 00, VARIABLE FREQUENCY DEVICE).

CORRECTIVE ACTION

1. Check for nominal 208 VAC between pins L1 and L2, L2 and L3, and L1 and L3 on the VFD.
 - a. If 197 to 229 VAC is present in all three phases, replace VFD.
 - b. Inadequate or no voltage at L1, L2 or L3 of the VFD.
2. Disconnect connector J9 from P9.
3. Check for nominal 208 VAC between pins 1 and 2, 1 and 3, and 2 and 3 of connector P9. If 197 to 229 VAC is present in all three phases, replace filter FL2.

STEP**INDICATION/CONDITION**

Measure Condenser Assembly compressor motor winding continuity (See WP 0045 00).

CORRECTIVE ACTION

1. Check continuity between:
 - P3-A and P3-B
 - P3-B and P3-D
 - P3-A and P3-D
2. If continuity is not present, replace the condenser compressor.
(See WP 0034 00)

FAULT PROCEDURE 2 - NO COOLING - NO INDICATOR LAMP ILLUMINATED (Con't)**STEP****INDICATION/CONDITION**

Measure Condenser Assembly P3 to Compressor for continuity (See WP 0045 00).

CORRECTIVE ACTION

1. Check continuity between:
 - P3-A and Compressor T1
 - P3-B and Compressor T2
 - P3-C and Compressor T3
 - a. If continuity is present, replace compressor assembly.
 - b. If continuity is not present, replace condenser junction box (See WP 0024 00).

FAULT PROCEDURE 2 - NO COOLING - NO INDICATOR LAMP ILLUMINATED (Con't)**NOTE**

Additional fault messages listed in (Table 1, Variable Frequency Device (VFD) fault message table.) may be shown on the variable frequency device display. For fault messages other than "LF" Low DC Bus Voltage Fault. Line Voltage is too low, replace the VFD. (See WP 0018 00, VARIABLE FREQUENCY DEVICE)

Table 1. Variable Frequency Device (VFD) Fault Message Table

AF	High Temperature Fault: Ambient temperature is too high. Cooling fan has failed.
LF	Low DC Bus Voltage Fault: Line Voltage is too low.
PF	Current Overload Fault: VFD is undersized for the application. Mechanical problem with the driven equipment
F2-F9, Fo	Internal Faults: The control board has sensed a problem.

FAULT PROCEDURE 3 - OVER PRESSURE AND UNDER PRESSURE LAMPS ARE ILLUMINATED IN COOL MODE.**SYMPTOM**

Faulty Condenser Assembly, coil temperature thermistor.

INDICATION/CONDITION

Over pressure and under pressure lamps on remote control unit illuminate simultaneously when cool mode is selected.

CORRECTIVE ACTION

1. Replace condenser coil assembly (See WP 0026 00).

FAULT PROCEDURE 4 - INSUFFICIENT HEATING, NO INDICATOR LAMPS ILLUMINATED.**SYMPTOM**

Insufficient heating with no indicator lamp illuminated on remote control unit when LO or HI heat mode is selected.

INDICATION/CONDITION

Insufficient heat with no indicator lamp illuminated on remote control unit.

CORRECTIVE ACTION

1. Increase temperature control to maximum heat position.
2. Check shelter duct system for obstructions.
3. Check fresh and return inlets/outlets for air flow.
4. Check continuity between P2 - C and P2 - E on the remote control unit in the HI HEAT mode and P2 - D and P2 - E on the remote control unit in the LO HEAT mode. If no continuity is measured in either mode, replace the remote control unit.

STEP**INDICATION/CONDITION**

Heater Assembly low heat bank element not operating in LO heat mode.

CORRECTIVE ACTION

1. Check K2 relay (See WP 0045 00) for 16 ± 3 ohms of resistance between:
T1 and T2
T2 and T3
T1 and T3
2. If no continuity is present, replace low heater bank elements. (See WP 0016 , HEATER ASSEMBLY)

STEP**INDICATION/CONDITION**

Heater Assembly high heat bank element not operating in HI heat mode.

CORRECTIVE ACTION

1. Check K3 relay (See WP 0045 00) for 23 ± 3 ohms of resistance between:
 - T1 and T2
 - T2 and T3
 - T1 and T3
2. If no continuity is present, replace high heater bank elements. (See WP 0016 00, HEATER ASSEMBLY)

STEP**INDICATION/CONDITION**

Relays K2 (LO heat) and K3 (HI heat) fail to engage when modes selected.

CORRECTIVE ACTION

1. Disconnect connector P108 from circuit board PC2.
2. Check continuity between P108 - 7 and P108 - 8.

NOTE

Thermistor RV2 is attached to the evaporator frame assembly adjacent to the front of the evaporator coil.

3. If shorted, replace RV2. (RV2 normally reads open).

FAULT PROCEDURE 5 - INSUFFICIENT HEAT WITH OVER TEMPERATURE LAMP ILLUMINATED**SYMPTOM**

Insufficient heating with "OVER TEMPERATURE" indicator lamp illuminated on remote control unit when LO or HI heat mode is selected.

FAULT PROCEDURE 5 - INSUFFICIENT HEAT WITH OVER TEMPERATURE LAMP ILLUMINATED (Con't)**INDICATION/CONDITION**

Insufficient heating and "OVER TEMPERATURE" indicator lamp illuminated on remote control unit when LO or HI heat mode is selected.

CORRECTIVE ACTION

1. Increase temperature control to maximum heat position.
2. Check shelter duct system for obstructions.
3. Check fresh and return inlets/outlets for air flow.
4. Check Blower and Motor Assembly for airflow.
5. Separate P105 from Circuit Board Assembly PC2.
6. Check continuity between P105 - 1 and P105 -2. If continuity is not present, remove blower and motor assembly from evaporator (See WP 0017 00, EVAPORATOR BLOWER AND MOTOR ASSEMBLY).
7. Remove connector from one side of SW2 (See WP 0045 00).
8. Check continuity between terminals of SW2. If continuity is not present, replace SW2.
9. Remove connector from one side of SW3 (See WP 0045 00).
10. Check continuity between terminals of SW3. If continuity is not present, replace SW3.
11. If continuity is present for SW2 and SW3, replace Circuit Card Assembly PC2.

FAULT PROCEDURE 6 - OVER PRESSURE INDICATOR LAMP ILLUMINATED**SYMPTOM**

Over pressure indicator lamp on remote control unit is illuminated.

INDICATION/CONDITION

Over pressure indicator lamp on remote control unit is illuminated during operation.

CORRECTIVE ACTION**NOTE**

Power the environmental control unit down. To permit time for the compressor internal pressure switch to reset, allow the compressor to sit idle a minimum thirty minutes. After wait time has elapsed, start the ECU.

1. Inspect coil assembly for obstructed airflow.
2. Remove terminal lead for one side of high pressure switch SW5.
3. Check continuity between terminals 1 and 2 on SW5. If continuity is not present, replace high pressure switch SW5.
4. Observe blower motor for engagement. If blower motor fails to start, replace blower motor. (See WP 0027 00, CONDENSER BLOWER AND MOTOR ASSEMBLY).

FAULT PROCEDURE 7 - UNDER PRESSURE INDICATOR LAMP ILLUMINATED**SYMPTOM**

Under pressure indicator lamp on remote control unit is illuminated.

INDICATION/CONDITION

Under pressure indicator lamp on remote control unit is illuminated during operation.

CORRECTIVE ACTION

1. Inspect coil assembly for obstructed airflow.
2. Check refrigerant pressure at service ports. (WP 0039 00, REFRIGERANT PRESSURE CHECK)

FAULT PROCEDURE 7 - UNDER PRESSURE INDICATOR LAMP ILLUMINATED (Con't)

3. Remove terminal lead for one side of low pressure switch SW4.
4. Check continuity between terminals 1 and 2 on SW4. If continuity is not present, replace low pressure switch SW4.
5. Inspect system for leaks (See WP 0040 00, LEAK TESTING THE REFRIGERANT R410-A SYSTEM). If leakage of the under pressure switch is observed, replace SW4 (See WP 0032 00 LOW PRESSURE SWITCH).
6. Repair leaks. (See WP 0040, WP 0041 and WP 0042).

END OF WORK PACKAGE

Chapter 4

FIELD LEVEL

24,000 BTUH, SPLIT PACK ENVIRONMENTAL CONTROL UNIT (ECU)

**NSN 4120-01-516-4715
F24H4-2**

CHAPTER 4
FIELD LEVEL
MAINTENANCE INSTRUCTIONS

WORK PACKAGE INDEX

<u>Title</u>	<u>WP Sequence No.</u>
SERVICE UPON RECEIPT	0009 00
PMCS PROCEDURES	0010 00
MAINTENANCE INSTRUCTIONS	0011 00
EVAPORATOR ASSEMBLY AND CONDENSER ASSEMBLY SEPARATION AND RECONNECTION	0012 00
EVAPORATOR ASSEMBLY	0013 00
EVAPORATOR HOUSING ASSEMBLY	0014 00
EVAPORATOR COIL ASSEMBLY	0015 00
HEATER ASSEMBLY	0016 00
EVAPORATOR MOTOR AND BLOWER ASSEMBLY	0017 00
VARIABLE FREQUENCY DEVICE (VFD)	0018 00
EVAPORATOR COVERS	0019 00
HARMONIC FILTER FL2	0020 00
EVAPORATOR HARNESS ASSEMBLIES	0021 00
EXPANSION (THERMOSTATIC) VALVE	0022 00
CONDENSER ASSEMBLY	0023 00
JUNCTION BOX ASSEMBLY	0024 00
CONDENSER COVERS	0025 00
CONDENSER COIL ASSEMBLY	0026 00
CONDENSER BLOWER AND MOTOR ASSEMBLY	0027 00
CONDENSER HOUSING	0028 00

FIELD LEVEL

24,000 BTUH, SPLIT PACK ENVIRONMENTAL CONTROL UNIT (ECU)

NSN 4120-01-516-4715
F24H4-2

SERVICE UPON RECEIPT

0009 00

Perform service upon receipt of the Environmental Control Unit in the following manner.

1.
 - a. Inspect the equipment for damage incurred during shipment. If the equipment has been damaged, report damage on DD Form 6, Packaging Improvement Report.
 - b. Check the equipment against the packing slip to see if the shipment is complete. Report all discrepancies in accordance with the instructions of TM 38-750 The Army Maintenance Management System (TAMMS).

INTRODUCTION

GENERAL. Systematic, periodic, preventive maintenance checks, and services (PMCS) are essential to ensure that the Environmental Control Unit is ready for operation in any mode at all times. The purpose of a preventive maintenance program is to discover and correct defects and deficiencies before they can cause serious damage or complete failure of the equipment. Any effective preventive maintenance program must begin with the training of operators to report all unusual conditions noted during daily checks or actual operation to unit maintenance. All defects and deficiencies discovered during maintenance inspections must be recorded, together with corrective action taken, on DA Form 2404 (Equipment Inspection and Maintenance Worksheet).

INSPECTION AND SERVICE SCHEDULING

1. A schedule for unit preventive maintenance inspection and service should be established immediately after installation of the Environmental Control Unit . A quarterly interval, equal to three calendar months or 250 hours of operation, whichever occurs first, is recommended for usual operating conditions. When operating under unusual conditions, such as a very dusty or sandy environment, it may be necessary to reduce the interval to monthly or even less if conditions are extreme.
2. The following table lists the unit preventive maintenance checks and services that should be performed at quarterly (or otherwise established) intervals. The PMCS items in the table have been arranged and numbered in a logical sequence to provide for greater personnel efficiency and least amount of required maintenance downtime.

END OF WORK PACKAGE

FIELD LEVEL

24,000 BTUH, SPLIT PACK ENVIRONMENTAL CONTROL UNIT (ECU)

NSN 4120-01-516-4715

F24H4-2

FIELD PREVENTIVE MAINTENANCE CHECKS AND SERVICES (PMCS)

0010 00

INITIAL SETUP:

Personnel Required

Field level Technician (2)

Equipment Condition

Environmental Control Unit (shut down)

NOTE

Preventive Maintenance Checks and Services are performed in conjunction with shelter preventive maintenance intervals.

Table 1. Preventive Maintenance Checks and Services

ITEM NO.	INTERVAL	MAN-HOUR	ITEM TO BE CHECKED OR SERVICE	CREW MEMBER PROCEDURE	EQUIPMENT NOT READY / AVAILABLE IF:
1		0.1	Fresh Air Cover	<p style="text-align: center;">NOTE</p> <div style="border: 1px solid black; padding: 5px; margin: 10px auto; width: fit-content;"> <p>Check all air filters at least weekly for airflow blockage</p> </div> <p>a. Check that there are no major dents, punctures, cracks, or missing hardware.</p> <p>b. Check that gaskets are in good condition and that they seal properly. Gaskets on this item act both as an air seal and as an EMI seal.</p>	
2		0.1	Top Cover	<p>a. Check that there are no major dents, punctures, cracks, or missing hardware.</p> <p>b. Check that gaskets are in good condition and that they seal properly. Gaskets on this item act both as an air seal and as an EMI seal.</p>	

Table 1. Preventive Maintenance Checks and Services (continued)

ITEM NO.	INTERVAL	MAN-HOUR	ITEM TO BE CHECKED OR SERVICE	<u>CREW MEMBER PROCEDURE</u>	EQUIPMENT NOT READY / AVAILABLE IF:
3		0.1	Evaporator Housing (Exposed portions only)	a. Check that there are no major dents, punctures, cracks, or missing hardware. b. Check that gaskets are in good condition and that they seal properly. Gaskets on this item act both as an air seal and as an EMI seal.	
4		0.1	Access Cover	a. Check that there are no major dents, punctures, cracks, or missing hardware. b. Check that gaskets are in good condition and that they seal properly. Gaskets on this item act both as an air seal and as an EMI seal.	
5		0.1	Information and Identification Plates	a. Check that all Warning, information and identification plates are in place and legible.	
6		0.1	Evaporator Front Cover	a. Check that there are no major dents, punctures, cracks, or missing hardware. b. Check that EMI screens for dents, punctures, cracks and that they seal properly.	
7		0.1	Evaporator Drain Holes	a. Ensure drains are free of debris and obstructions.	
8		0.1	Condenser Guard	a. Check that there is no damage. b. Check for blockage or obstruction.	
9		0.1	Condenser Discharge Grille	a. Check that there is no damage. b. Check for blockage or obstruction.	
10		0.1	Condenser Intake EMI Screens	a. Observe for damages, such as punctures, cuts, or dented areas. b. Observe for air flow blockage.	
11		0.1	Condenser Discharge EMI Screen	a. Observe for damages, such as punctures, cuts, or dented areas. b. Observe for air flow blockage.	
12		0.1	Knobs, Remote Control	Check that remote control knobs are in place and not broken.	

Table 1. Preventive Maintenance Checks and Services (continued)

ITEM NO.	INTERVAL	MAN-HOUR	ITEM TO BE CHECKED OR SERVICE	CREW MEMBER PROCEDURE	EQUIPMENT NOT READY / AVAILABLE IF:
13		0.1	Remote Control Cable (Visible Portions)	a. Check that cable is in good condition. b. Check that cable is placed so that it will not be damaged or create problems for operating personnel.	
14		0.1	Power Cable (Visible Portions)	a. Check that cable is in good condition. b. Check that cable is placed so that it will not be damaged or create problems for operating personnel.	
15		0.3	Operational Checks	a. Be sure the mode selector switch is in the OFF position b. Perform functional check of the ECU in all operational modes in accordance with the instructions in WP 0005 00, INITIAL ADJUSTMENTS, BEFORE USE AND SELF TEST . <p style="text-align: center;">CAUTION</p> <div style="border: 1px solid black; padding: 5px;"> <p>If military operational considerations allow the time, it will help extend the life of the compressor if the ECU is not turned on for its check of operation in the COOL mode until after a sufficient time to eliminate any danger of liquid refrigerant accumulation in the compressor. Except in extremely cold conditions, if input power has been is connected for a period of less than six hours, an equal warm-up period is desirable. If the disconnected period has been more than six hours, a full six-hour warm-up period is recommended.</p> </div>	

Table 1. Preventive Maintenance Checks and Services (continued)

ITEM NO.	INTERVAL	MAN-HOUR	ITEM TO BE CHECKED OR SERVICE	<u>CREW MEMBER PROCEDURE</u>	EQUIPMENT NOT READY / AVAILABLE IF:
16		0.1	Power On Indicator Lamp	a. Lamp should be illuminated in all operating modes. b. Lamp should remain off with MODE SELECTOR SWITCH in OFF position.	
17		0.1	Sight Glass	a. Operate ECU at least 15 minutes in COOL MODE with TEMPERATURE CONTROL set at COOLER. b. Center indicator on sight glass should be green. Refrigerant should be clear with no bubbles. c. If center indicator is yellow, or refrigerant is milky, or bubbles are seen, report condition to direct support maintenance.	
18		0.3	Condensate Drain	After ECU has been running in cool mode, check it to see that no water is dripping, except through drain. Set-up the ECU for the desired operational mode. Record performance of quarterly PMCS, including all corrective actions taken. <p style="text-align: center;">NOTE</p> <div style="border: 1px solid black; padding: 5px; margin: 5px auto; width: fit-content;"> <p>If the ECU has been in operation under unusual conditions, the above PMCS items may be modified as necessary to meet the further requirements due to the unusual conditions.</p> </div>	

END OF WORK PACKAGE

FIELD LEVEL

24,000 BTUH, SPLIT PACK ENVIRONMENTAL CONTROL UNIT (ECU)

NSN 4120-01-516-4715
F24H4-2

MAINTENANCE INSTRUCTIONS

0011 00

INITIAL SETUP:

Tools And Special Tools

Recovery and Recycle Unit 5250-01-338-2707
Heat Gun 4940-01-042-4855
Multimeter 6625-01-265-6000
Nitrogen Regulator 4935-00-040-9916
Vacuum Pump 4310-00-098-5272
Soldering Iron 3439-00-930-1638

The procedures in this section have been arranged in the order in which the items appear in the unit (O) maintenance level column on the Maintenance Allocation Chart (MAC). Procedures have been provided for actions authorized to be performed by maintenance personnel in the order in which they appear on the MAC. Actions authorized to be Field and Sustainment support maintenance have been duly noted. For authorized common tools and equipment, refer to the Modified Table of Organization and Equipment (MTOE) applicable to your unit. Test, maintenance, and diagnostic equipment (TMDE) and support equipment include electrical test equipment, standard pressure and vacuum gages, vacuum pumps, and charging manifolds found as standard equipment in any direct support refrigeration shop. Repair parts are listed and illustrated in the Repair Parts and Special Tools (RPSTL) TM 9 4120-429-24P covering field and sustainment maintenance for this equipment. Tool Kit, Service, Refrigeration Unit, NSN 5180-00-597-1474 contains hand tools and equipment used for Environmental Control Unit maintenance. The following common items not contained in the refrigeration unit tool kit are also required for Environmental Control Unit maintenance.

END OF WORK PACKAGE

FIELD LEVEL

24,000 BTUH, SPLIT PACK ENVIRONMENTAL CONTROL UNIT (ECU)

NSN 4120-01-516-4715
F24H4-2

EVAPORATOR ASSEMBLY AND CONDENSER ASSEMBLY SEPARATION AND RECONNECTION

0012 00

INITIAL SETUP:

Personnel Required

Field Level Technician (2)

Equipment Condition

ECU removed from shelter. See WP 0005 00, INSTALLATION SITE PREPARATION
Access cover removed. See WP 0019 00, EVAPORATOR ACCESS AND FRESH AIR COVERS
Right end condenser screen guard removed. See WP 0025 00, CONDENSER COVERS
Left end condenser screen guard removed. See WP 0025 00, CONDENSER COVERS
top cover removed. See WP 0025 00, CONDENSER COVERS.

References:

TM 9-4120-429-24P

DISASSEMBLY

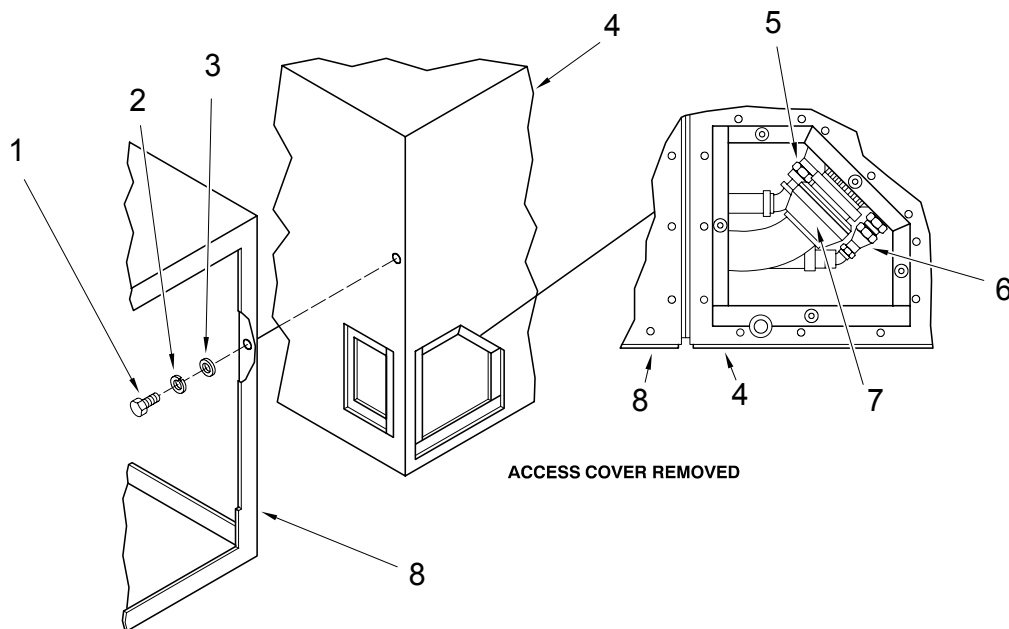

Figure 1. EVAPORATOR /CONDENSER ASSEMBLY - SEPARATION AND RECONNECTION.

1. Remove cap screws (1), lockwashers (2), and flat washers (3) that hold the evaporator (4) and condenser (8) assemblies together. See Figure 1.
2. Disconnect the P3 (7) connector.

CAUTION

Use a wrench to hold lower portion of compression fittings to prevent loosening of fittings or twisting of copper tubing.

3. Carefully disconnect the low (5) and high (6) condenser to evaporator refrigerant metal hose line connectors from the evaporator assembly (4) half couplings.
4. Carefully pull the evaporator assembly (4) away from the condenser assembly (8).

ASSEMBLY

1. On a level surface, place the back of the evaporator assembly (4) next to the back of the condenser (8) section.
2. Carefully guide the refrigerant metal hose assemblies and connector P3 (7) through the evaporator housing opening and slide the evaporator (4) and condenser (8) assemblies together.
3. Align the four evaporator/condenser mounting holes.
4. Connect the low (5) and high (6) pressure condenser to evaporator assembly (4) refrigerant line couplings.
5. Leak test the connections. (See WP 0040 00, LEAK TESTING THE REFRIGERANT R-410A SYSTEM)
6. Connect P3 (7) connector.
7. Attach evaporator (4) and condenser (8) assemblies together with four each hex head cap screws (1), lockwashers (2), and flat washers (3).
8. Install left end condenser screen guard.
9. Install right end condenser screen guard.
10. Install access cover.
11. Install ECU on shelter. (See WP 0005 00, OPERATION UNDER USUAL CONDITIONS).

END OF WORK PACKAGE

FIELD LEVEL

24,000 BTUH, SPLIT PACK ENVIRONMENTAL CONTROL UNIT (ECU)

NSN 4120-01-516-4715
F24H4-2

EVAPORATOR ASSEMBLY

0013 00

INITIAL SETUP:

Discharge Screen Assembly 178K0096-1
Evaporator Coil Assembly 178K0015-1
Evaporator Assembly 001T0011-1

Tools And Special Tools

Tool Kit, Refrigeration Ordnance
5180-00-596-1474

Equipment Condition

ECU removed from shelter (See WP 0005 00,
INSTALLATION SITE PREPARATION)

Personnel Required

Unit Level Technician (1)

References:

TM 9-4120-429-24P

Materials/Parts

Return Screen Assembly 178K0152-1
Overheat Switch Assembly 178K0084-1
Heater Assembly 001T0016-1
Harmonic Filter Assembly 500T2592
Copper Tubing 178K0036-1
Cover Assembly 178K0307-1
EMI Filter Assembly 178K00312-1

NOTE

Unless otherwise indicated, all hardware and fasteners removed during removal procedures shall be retained for use in reinstallation of new or existing components.

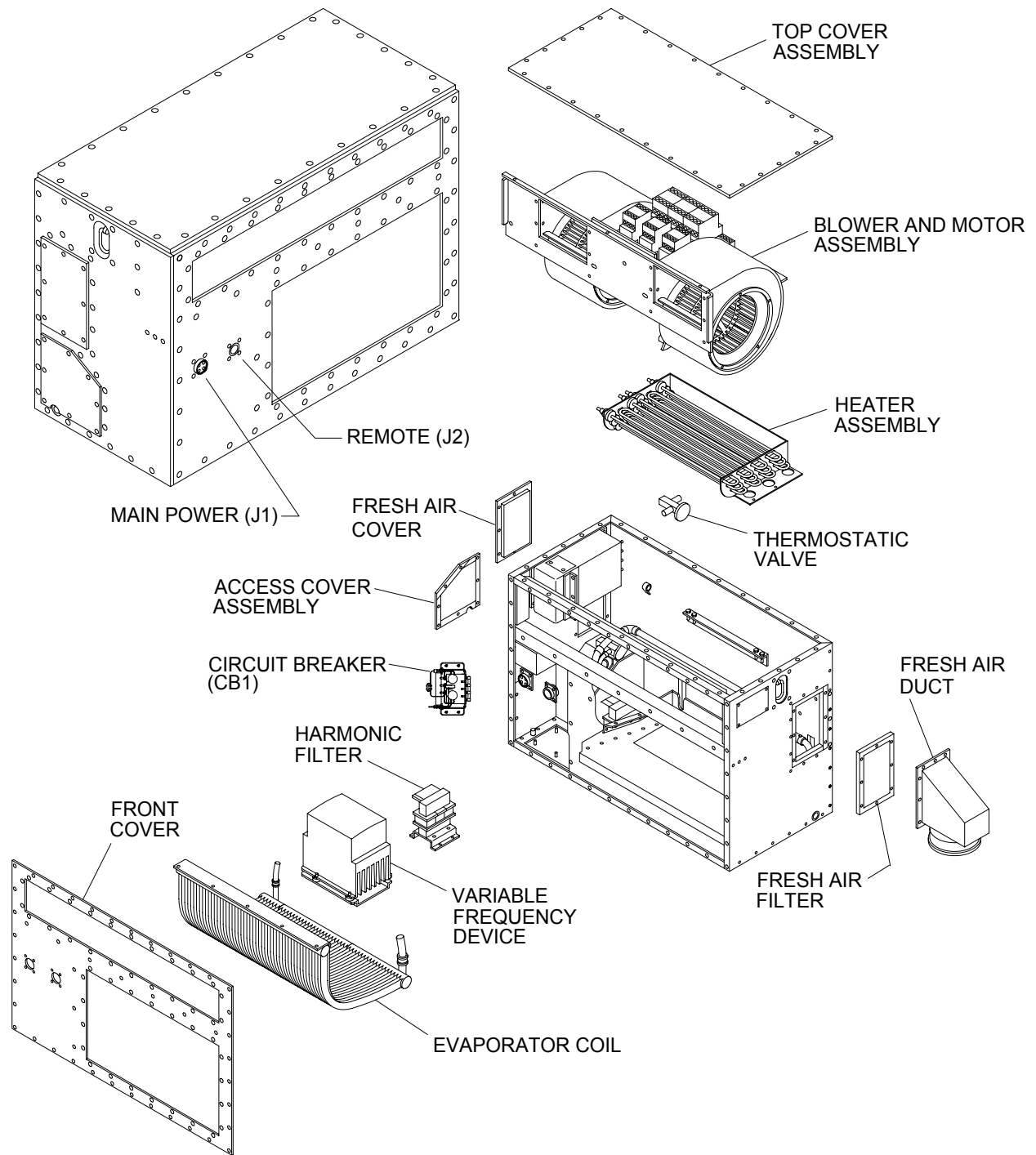

Figure 1. EVAPORATOR ASSEMBLY.

DRAIN PLUGS

The unit is shipped from the factory with drain plugs. These plugs must be removed prior to operation.

CAUTION

Failure to remove drain plugs will cause water to collect in the bottom of the evaporator section assembly and possible spillage into shelter.

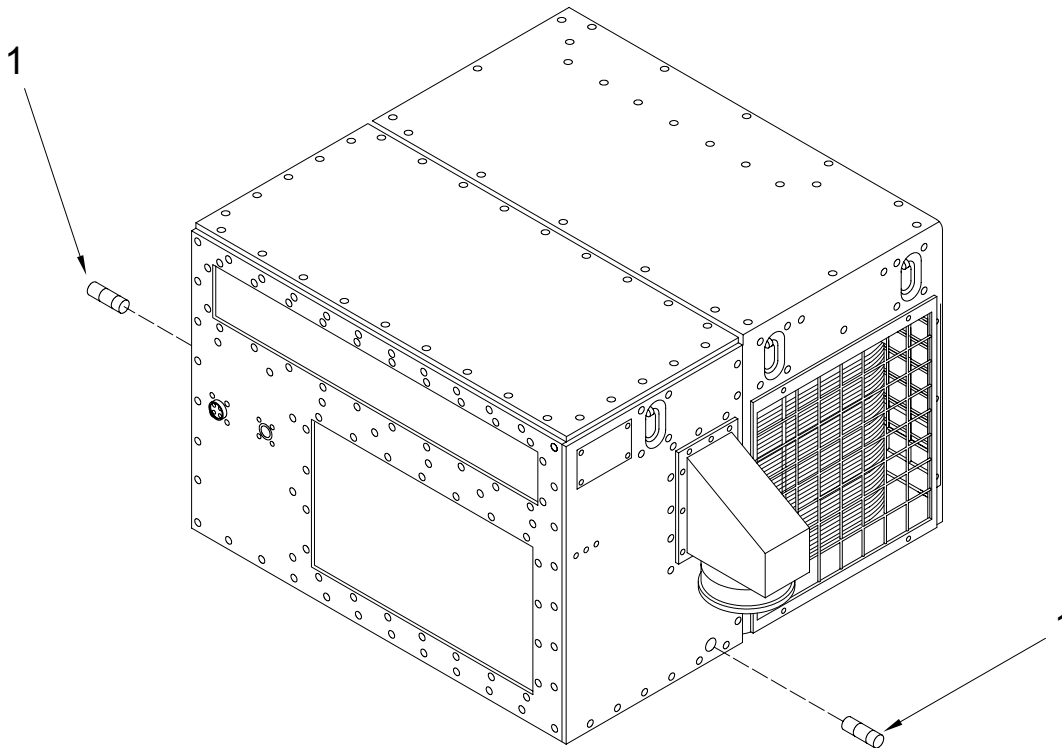

Figure 2. DRAIN PLUG REMOVAL/INSTALLATION.

REMOVAL

1. Prior to operation, remove drain plugs (1) from both sides of air conditioner. See Figure 2.

INSTALLATION

For shipment or extended storage, drain plugs (1) must be reinstalled or drain holes taped closed.

PROTECTIVE ELECTRICAL CAPS

INSPECTION

1. Check that internal threads are not damaged, and that chains (1) are in place. If cap (2) will not screw on connector, or chains are missing, the cap should be replaced.

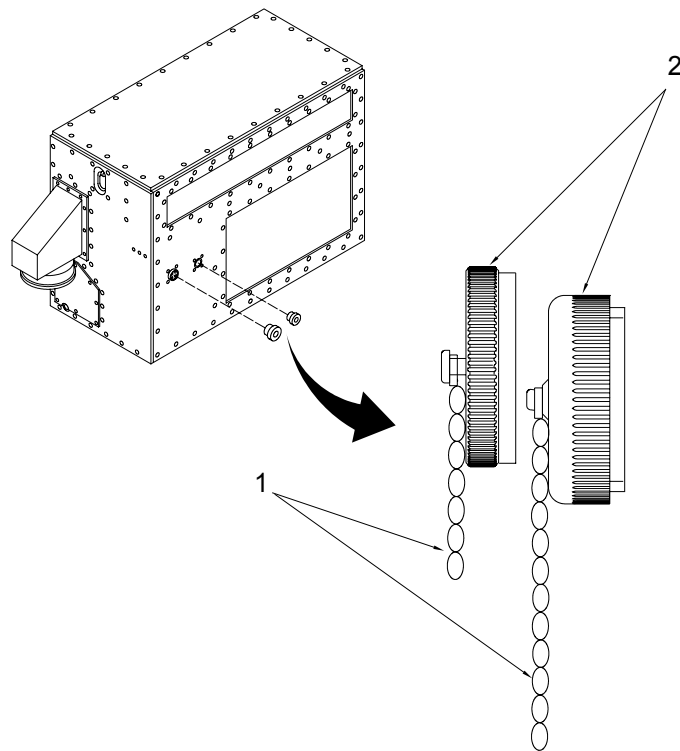

Figure 3. PROTECTIVE ELECTRICAL CAPS.

REMOVAL

1. Remove the screw from the end of the chain.
2. Unscrew cap from the connector.

INSTALLATION

1. Screw the cap in place on the connector.
2. Attach the end of the chain to the front evaporator cover.
3. Install air conditioner on shelter. (See WP 0005 00, INSTALLATION SITE PREPARATION)

FILTER RADIO FREQUENCY INTERFERENCE (EMI)

WARNING



Voltage (208 vac) remains present when the circuit breaker on front of the evaporator panel is in the off position. Electrical power can be removed by disconnecting the main power cable from J1 on front of the evaporator assembly.

NOTE

Environmental Control Unit schematic diagrams do not depict shelter electrical connectors. Evaporator Main Power connector (J1) and Remote Control connector (J2) connect to vehicle shelter Main Power cable connector (J8) and Remote Control cable connector (J7). Remote Control Unit connector (P2) connects to vehicle shelter Remote Control cable connector (J14).

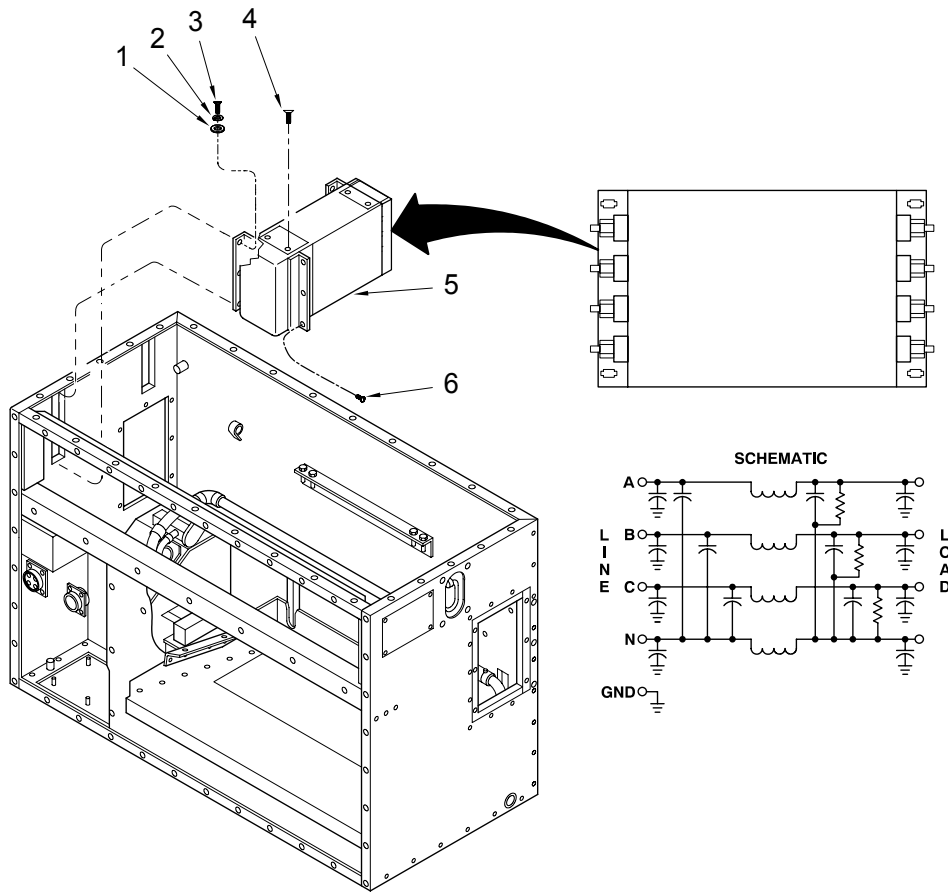

Figure 4. FILTER RADIO FREQUENCY INTERFERENCE (EMI).

INSPECTION

1. Check the radio frequency filter housing (5) for physical damage such as dents, punctures, cuts, and ruptured seams. Replace if damaged. See Figure 4.
2. Look for evidence of overheating. Replace if overheating is indicated.
3. Check that connectors are secure and contacts are tight and not damaged. Replace if connectors are loose or damaged.

REMOVAL

1. Insuring main power is disconnected, remove screws from the evaporator top cover. Remove top cover.
2. Remove screws (4) securing covers on input and output ends of the EMI filter.
3. Remove nuts and washers securing wiring to line and load terminals. Label each wire as removed to assist in reinstalling the wires.

CAUTION

Failure to remove drain plugs will cause water to collect in the bottom of the evaporator section assembly and possible spillage into shelter.

4. Remove mounting screws (3), lockwashers (2), and flat washers (1) securing the EMI filter to the evaporator assembly housing. See Figure 4.
5. Remove the EMI filter.

INSTALLATION

1. Locate the EMI filter in the evaporator housing assembly and align mounting holes.
2. Install mounting screws (3), lockwashers (2) and flat washers (1) to secure the EMI filter to the evaporator housing assembly. See Figure 4.
3. Install wiring to the line and load terminals using nuts and washers. Refer to wiring diagram (WP 0045 00, Figure 1) to verify correct wire placement.
4. Align line end covers and install using screws (4).
5. Line up screw holes in top cover and evaporator housing assembly.
6. Install top cover with screws.
7. Install air conditioner on shelter (See WP 0005 00, INSTALLATION SITE PREPARATION) .

TESTING

1. Continuity test the filter. Replace if found bad.
2. Continuity test J1 to line side of EMI, A to A, B to B, C to C, D to N. (See WP 0045 00).

NOTE

Continuity testing does not necessarily predict the behavior of capacitors under load. If the filter still does not operate properly after passing the continuity test, substitute a filter known to be good

END OF WORK PACKAGE

FIELD LEVEL

24,000 BTUH, SPLIT PACK ENVIRONMENTAL CONTROL UNIT (ECU)

NSN 4120-01-516-4715
F24H4-2

EVAPORATOR HOUSING ASSEMBLY

0014 00

INITIAL SETUP:

Personnel Required

Field Level Technician (2)

Equipment Condition

Tools And Special Tools

Stiff Brush (1)

ECU removed from shelter (See WP 0005 00, INSTALLATION SITE PREPARATION)
Covers removed from Evaporator Housing as necessary.

Materials/Parts

Frame housing 178K0160-1
Dry Cleaning Solvent P-D-680 Type III
Adhesive, Sealant MIL-A-46106 Type I
Insulation Frame Assembly 178K0161-1
Modified Lifting Ring 13219E9553

(WP 0019 00, EVAPORATOR ACCESS AND FRESH AIR COVERS).

References

TM 9-4120-429-24P

INSPECTION

1. Check that reflective panels and insulation are securely attached. Repair if loose.
 - a. Check that insulation is not damaged or missing. Replace if missing, burned, or damaged.

NOTE

Prior to removal of old insulation, cut the new replacement material to size using the old item as a pattern.

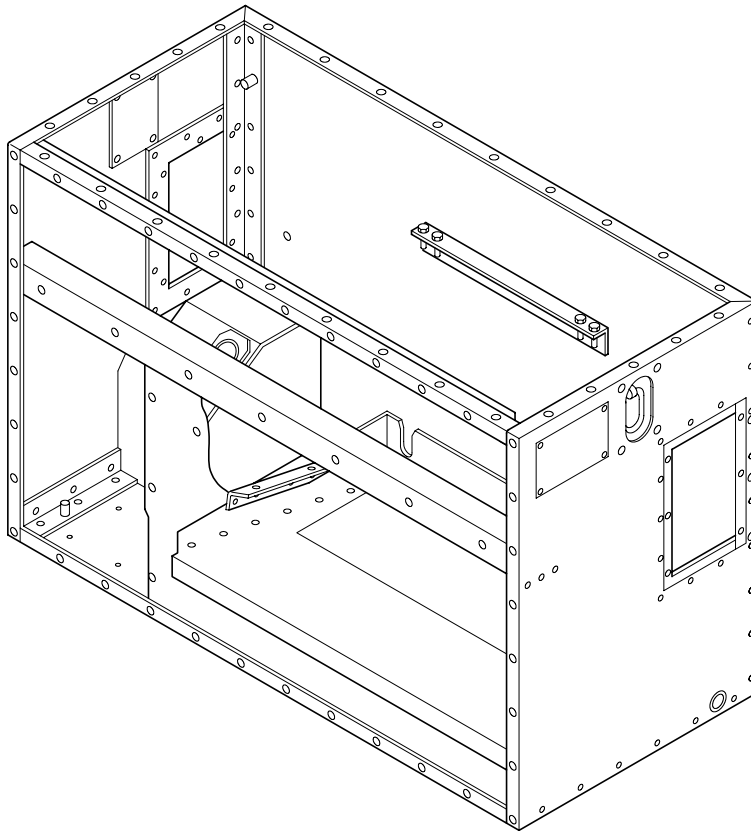

Figure 1. EVAPORATOR HOUSING ASSEMBLY.

REMOVAL

1. Remove as much old insulation material as possible by pulling or scraping it away from the metal surface.

WARNING



Dry Cleaning Solvent is flammable, and its vapors can be explosive. Repeated or prolonged skin contact or inhalation of vapors can be toxic. Use a well-ventilated area, and keep away from sparks or flame. Use goggles, gloves, and apron when appropriate.

2. Soften and remove old adhesive and gasket residue, using dry cleaning solvent and a stiff brush.

INSTALLATION

1. Cut to size.
2. Be sure that the surface to which the insulation is to be applied is clean and free of paint and old adhesive material.
3. Coat the mating surfaces of the metal and the insulation with adhesive. Let both surfaces air dry until the adhesive is tacky, but will not stick to the fingers.

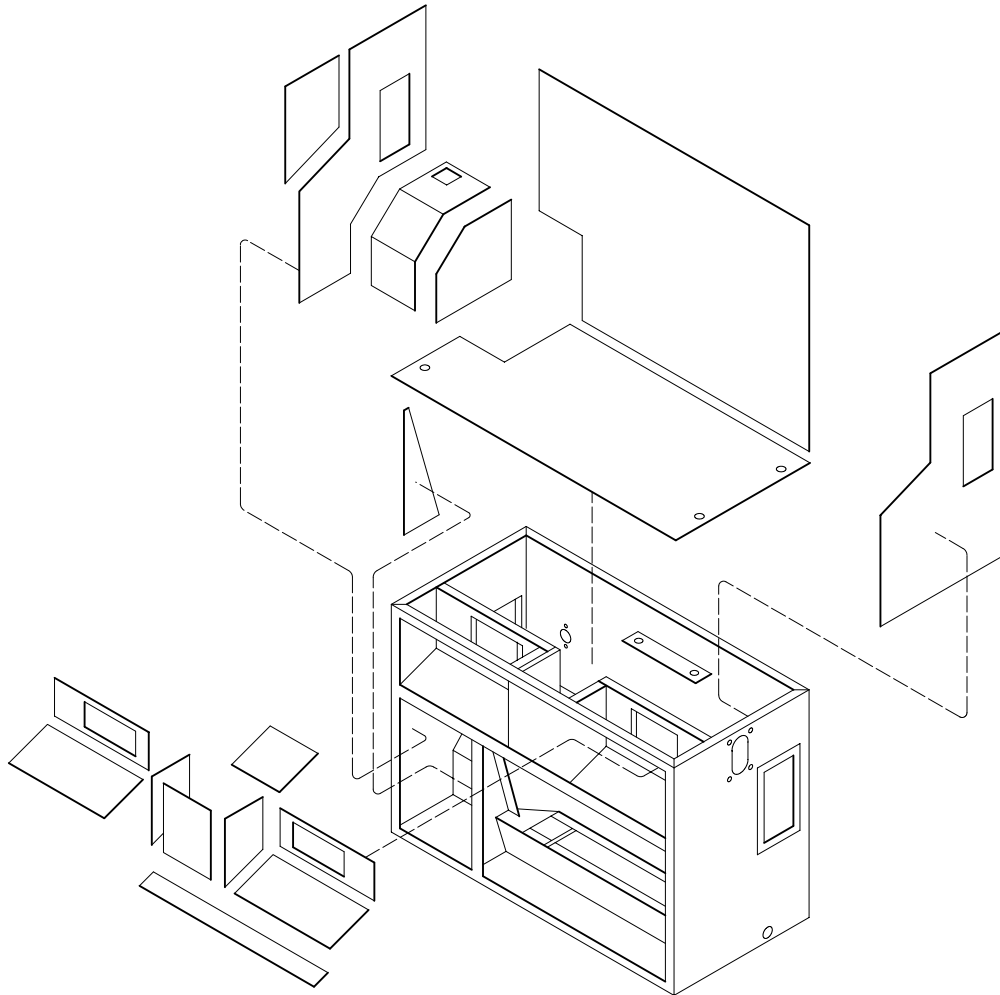

Figure 2. EVAPORATOR HOUSING ASSEMBLY - INSULATION.

4. Starting with an end, carefully attach the insulation to the metal. Press into firm contact all over.
5. Install all parts and covers that were removed.
6. Install Environmental Control Unit on shelter. (See WP 0005 00, INSTALLATION SITE PREPARATION).

END OF WORK PACKAGE

FIELD LEVEL

24,000 BTUH, SPLIT PACK ENVIRONMENTAL CONTROL UNIT (ECU)

NSN 4120-01-516-4715
F24H4-2

EVAPORATOR COIL ASSEMBLY

0015 00

INITIAL SETUP:

Personnel Required

Field Level Technician (2)

Tools And Special Tools

Tool Kit, Refrigeration Ordnance
5180-00-596-1474

Materials/Parts

Coil Assembly, Evaporator 001T0015
Bracket 178K0063-1
Bracket 178K0065-1
Adhesive 62-2216-0530-6
Coil panel perforated 178K0330-1
ACCESS AND FRESH AIR COVERS)
Front cover removed (See WP 0019 00,
EVAPORATOR ACCESS AND FRESH AIR
COVERS) Radio frequency filter
(See WP 0013 00, FILTER RAIDIO
FREQUENCY INTERFERENCE (EMI))
INSTALLATION SITE PREPARATION) Top
cover removed (See WP 0019 00,
EVAPORATOR Heater assembly removed (See
WP 0016 00, HEATER ASSEMBLY)

Equipment Condition

ECU removed from shelter (See WP 0005 00,
Blower and motor assembly removed (See WP
0017 00,
EVAPORATOR BLOWER AND MOTOR
ASSEMBLY)
Refrigerant R-410A system discharged
(See WP 0041 00, EVACUATING THE
REFRIGERANT R-410A SYSTEM)

References

TM 9-4120-429-24P

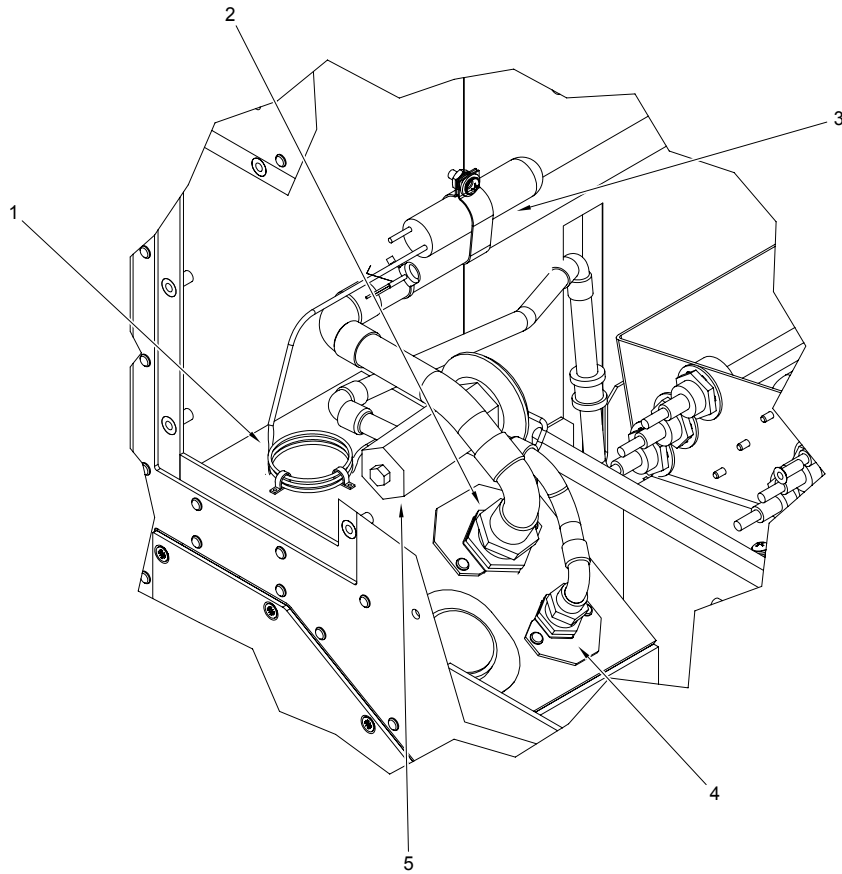

Figure 1. EVAPORATOR COIL - MALE COUPLING HALF AND THERMOSTATIC VALVE.

WARNING



When handling coils, wear gloves to avoid cuts and reduce fin damage on the coil.

CAUTION

Do not use steam to clean coil.

INSPECTION

1. Check coil for accumulated dirt. Clean if an accumulation of dirt is evident.
2. Check fins for dents, bent edges, or any condition that would distort airflow. Straighten all damaged fins with a plastic fin comb.

The coupling half fittings (hose disconnect fittings) used for joining the interconnecting Refrigerant R-410A metal hoses, contain a poppet valve assembly to prevent Refrigerant R-410A loss and to keep air from entering the line when hoses are disconnected. The following instructions apply to both the suction (low pressure) and discharge (high pressure) couplings.

3. Check couplings for cracks, breaks, loose connections, and evidence of leakage. Replace if damaged.
4. Leak test in accordance with WP 0040 00, LEAK TESTING THE REFRIGERANT R-410A SYSTEM.
5. Inspect thermostatic valve for evidence of leaks, kinked or otherwise damaged capillary line (1), and loose or missing valve stem cap. See Figure 1.

REMOVAL

WARNING



When handling coils, wear gloves to avoid cuts and reduce fin damage on the coil.

CAUTION

Use care to not damage or kink the capillary.

1. Remove the screws that hold the clamps that support the thermostatic valve (5) and thermostatic valve capillary line (1). See Figure 1.
2. Carefully disconnect the low (4) and high (2) condenser to evaporator Refrigerant R-410A metal hose line connectors from the coupling halves. See Figure 1.
3. Remove the two each jam nuts and gasket seals from the inside of the access area.
4. Remove screws and washers while supporting the evaporator coil (7). See Figure 2.
5. Using gloves to protect your hands and coil fins, carefully lift the coil (7) and tubing up and out front of the unit. See Figure 2.
6. Unwrap insulation tape (black cork tape) from joints that are to be debrazed and from the sensing bulb (3). See Figure 1.
7. Loosen the screws and nuts in the bulb straps that attach the sensing bulb (3) to the suction line, and pull the bulb (3) and thermistor TS1 (2) out of the straps. Take care to note the position (center top of suction line) of the bulb. See Figure 2.
8. Note exact position of thermostatic valve (6) on Refrigerant R-410A line. See Figure 2.

9. Wrap wet rags around thermostatic valve (6) body and distributor tubes. See Figure 2
10. Using torch, debraze and separate the distributor, elbow and equalizer line tubing from the thermostatic valve.
11. Remove thermostatic valve (6). See Figure 2.
12. Remove tape (black cork tape) securing thermistor RV2 (1). See Figure 2.
13. Remove RV2 (1). Figure 2.

WARNING

Compressed air used for cleaning purposes will not exceed 30 PSI (2.1 kg/cm²). Do not direct compressed air against the skin. Use goggles or full-face shield.

WARNING

When handling coils, wear gloves to avoid cuts and reduce fin damage on the coil.

CLEANING

1. Clean coil with a soft bristled brush, vacuum cleaner and brush attachment, or use compressed air at 30 psi or less from the inside of the coil to blow the dirt out. Take care to avoid fin damage. When using compressed air, wear safety glasses or goggles.
2. Rinse thoroughly in water.
3. Dry excess water prior to installation.

REPAIR OR REPLACEMENT

1. Coil repair is limited to replacement of rivets, plate nuts, and the straightening of dented fins.
2. Plate nuts may be removed by drilling out the old rivets using a drill bit slightly smaller than the diameter of the rivet.
3. Install new plate nut(s) and rivets.
4. If fins are dented or dented so that the airflow across the coil would be blocked, straighten them using a plastic fin comb.

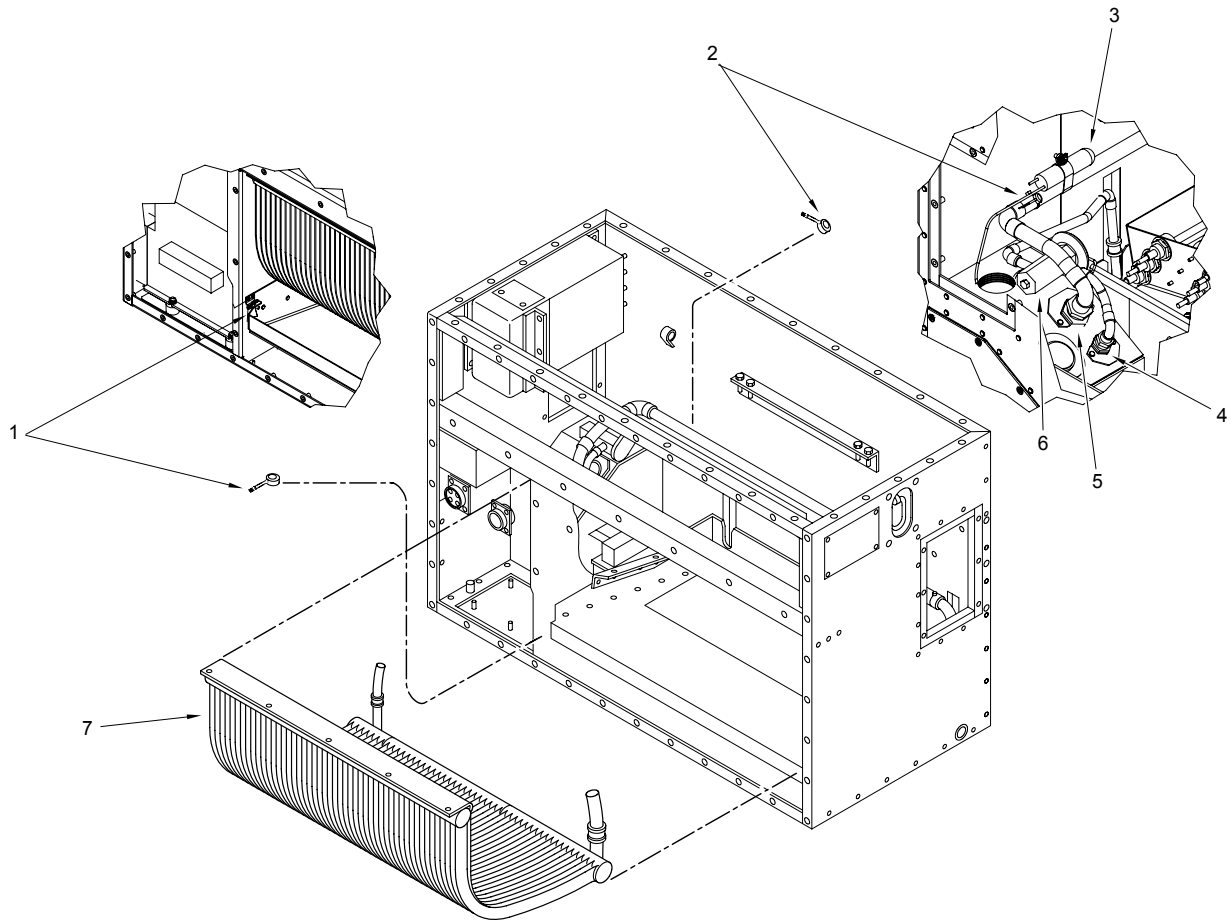

Figure 2. EVAPORATOR COIL ASSEMBLY

5. Carefully disconnect the low and high condenser to evaporator Refrigerant R-410A metal hose line connectors from the coupling halves. (See WP 0012 00, EVAPORATOR/CONDENSER ASSEMBLY - SEPARATION AND RECONNECTION).

WARNING

When handling coils, wear gloves to avoid cuts and reduce fin damage on the coil.

INSTALLATION

1. Tubing should be nitrogen purged during all brazing/debrazing operations.
2. Clean and prepare distributor, tubing and elbow prior to installing new thermostatic valve.
3. Place thermostatic valve (5) in original position and check that fittings and tubing fit properly into thermostatic valve solder cups. See Figure 1.
4. Wrap wet rags around thermostatic valve (6) body and distributor tubes. See Figure 2.
5. Braze the three thermostatic valve joints in accordance with WP 0043 00, BRAZING/DEBRAZING PROCEDURES.
6. Slip the sensing bulb (3) and thermistor TS1 (2) into its mounting straps. Be sure the bulb is on top of the suction line in original position and tighten the nuts and screws. Be sure the sensing bulb is making good metal-to-metal contact with the suction line. See Figure 2.
7. Replace the insulation tape that was removed from the sensing bulb (3) and thermostatic valve (6) connections.

CAUTION

Use care to not damage or kink the capillary.

8. Carefully place the evaporator coil, tubing, and fittings into the housing. See Figure 2.
9. Braze distributor to thermostatic valve joint.
10. Wrap wet rags around evaporator coil header.
11. Braze elbow in place on header in original position. (See WP 0043, BRAZING/DEBRAZING PROCEDURES).
12. Reaching in access area, and using care, push half couplings through holes in access.
13. Line up coil assembly (7) and housing screw holes. See Figure 2.
14. Fasten coil (7) to housing with screws and washers.
15. Fasten cushioned loop clamps to housing with screws.
16. Install jam nuts on half couplings in access. See Figure 1.
17. Carefully reconnect the low (4) and high (2) condenser to evaporator Refrigerant R-410A metal hose line connectors to the coupling halves.
18. Install thermistor RV2 (1) at lower left side of coil. See Figure 2.
19. Replace the filter dryer assembly. (See WP 0030 FILTER-DRYER REFRIGERANT).

20. Leak test the coil, the dehydrator, the newly brazed joints, and the joints in the area of the newly brazed joints per WP 0040 00, LEAK TESTING THE REFRIGERANT R-410A SYSTEM.
21. Evacuate and charge the refrigeration system in accordance with WP 0041 00, EVACUATING THE REFRIGERANT R-410A SYSTEM and WP 0042 00, CHARGING THE REFRIGERANT R-410A SYSTEM.
22. Install the heater assembly. (See EVAPORATOR COIL ASSEMBLY).
23. Install the blower and motor assembly. (See WP 0017 00, EVAPORATOR BLOWER AND MOTOR ASSEMBLY).
24. Install the front evaporator cover and radio frequency (EMI) filter. (See WP 0019 00, EVAPORATOR ACCESS AND FRESH AIR COVERS and WP 0013 00, EVAPORATOR ASSEMBLY).
25. Install the access cover. (See WP 0019 00, EVAPORATOR ACCESS AND FRESH AIR COVERS).
26. Install Environmental Control Unit on shelter. (See WP 0005 00, INSTALLATION SITE PREPARATION).

ADJUSTMENT

1. The thermostatic valve (6), as supplied with the unit, is preset at the factory. This valve should not be adjusted unnecessarily. When adjustment is necessary, see the following instructions. See Figure 1.
2. Remove insulation from a spot on the suction line near the sensing bulb of the thermal thermostatic valve to be adjusted.
3. Install an accurate thermometer or the probe of a thermocouple on a bare spot, using a small amount of the thermal mastic, if available, to improve conductivity. Tape the thermometer bulb or thermocouple junction in position, and cover with insulating material.
4. Connect LOW SIDE hose of charging manifold to unit LOW SIDE service valve.
5. Check that manifold valves are closed.
6. Loosen the hose connections at the charging manifold slightly.
7. Slightly open the unit LOW SIDE service valve to allow a small amount of Refrigerant R-410A to purge the hose. Tighten the hose connection at the manifold.
8. Fully open the LOW SIDE service valve.
9. Hold the front cover harnesses and cables in place in mounted position on the unit to minimize air leaks.
10. Operate the ECU in the cooling mode for about 30 minutes, briefly removing front panel and observing the thermometer or thermocouple dial to see that the temperature has stabilized. When the temperature remains unchanged for at least two minutes, record the temperature and pressure.
11. The temperature measured should register approximately 12° F (6.7° C) higher than the temperature listed on the table.
12. If adjustment is necessary, remove the cap from the thermostatic valve and turn the adjusting stem counterclockwise to decrease the superheat and clockwise to increase the superheat. When adjusting the valve, make no more than one turn of the stem at a time and observe the change in the superheat closely to prevent overshooting the desired setting. Allow unit to stabilize before taking reading.
13. When the proper setting is obtained, turn off Environmental Control Unit and replace the cap on the valve adjusting stem.
14. Remove the thermometer or thermocouple probe from the suction line, and replace the insulating material. Close the LOW SIDE service valve, remove the charging manifold and hose, and install the cap on the service valve gage port.

TESTING

1. Unwrap the insulation from the evaporator coil suction line so that thermal sensing bulb (3) is exposed. See Figure 1.
2. Loosen the screws and nuts in the bulb straps that attach the sensing bulb to the suction line, and pull the bulb out of the straps. Take care to note the position (center top of suction line) of the bulb.
3. Connect a remote control module and a power cable to the Environmental Control Unit.

CAUTION

Turn the Environmental Control Unit to OFF as soon as a definite drop in temperature is felt on the suction return line. If the test conditions are continued more than a few seconds the thermostatic valve will fully open and an excessive flood-back of liquid Refrigerant R-410A may damage or destroy the compressor.

4. Turn on power to Environmental Control Unit.

WARNING

AC power tests must be conducted with the power on. Exercise extreme caution.

5. Place the sensing bulb (3), Figure 1 in a container of ice water or crushed ice so that it is reduced to a temperature near 32°F (0° C).
6. Set the temperature thermostat control knob fully counterclockwise to COOLER position, place one hand on the exposed suction line, and start the Environmental Control Unit in COOL mode. If a drop in temperature is felt on the suction return line, the thermostatic valve is not closing fully and should be adjusted or replaced.
7. With one hand still on the suction return line, remove the sensing bulb (3) from the container and warm it in the other palm. If a temperature drop is not felt in the suction return line by the time the sensing bulb no longer feels cold to the hand, the thermostatic valve is not opening and should be adjusted or replaced. As soon as a temperature drop is felt, turn the Environmental Control Unit to OFF.

END OF WORK PACKAGE

FIELD LEVEL

24,000 BTUH, SPLIT PACK ENVIRONMENTAL CONTROL UNIT (ECU)

NSN 4120-01-516-4715
F24H4-2

HEATER ASSEMBLY

0016 00

INITIAL SETUP:

References

TM 9-4120-429-24P

Personnel Required

Unit Level Technician (1)

Equipment Condition

ECU removed from shelter (See
WP 0005 00, INSTALLATION SITE
PREPARATION
Top evaporator cover removed (See
WP 0019 00, EVAPORATOR ACCESS AND
FRESH
AIR COVERS
Blower and motor assembly removed (See
WP 0017 00, EVAPORATOR BLOWER AND
MOTOR
ASSEMBLY
Power disconnected

Tools And Special Tools

Tool Kit, Refrigeration Ordnance
5180-00-596-1474

Materials/Parts

Heating Element 500T2585-1
Heating Element 500T2585-2
Frame Heater 178K0223-1

INSPECTION

WARNING



Allow heaters to cool before touching. Severe burns can result from touching hot heaters.

1. Visually inspect each heater for obvious damage, deformation, cracked or broken sheath, burnt out spots and loose, broken, or otherwise damaged leads. Replace if any damage is found.
2. Check heater mounting bracket for cracks, breaks, and severe dents. Replace if damaged.

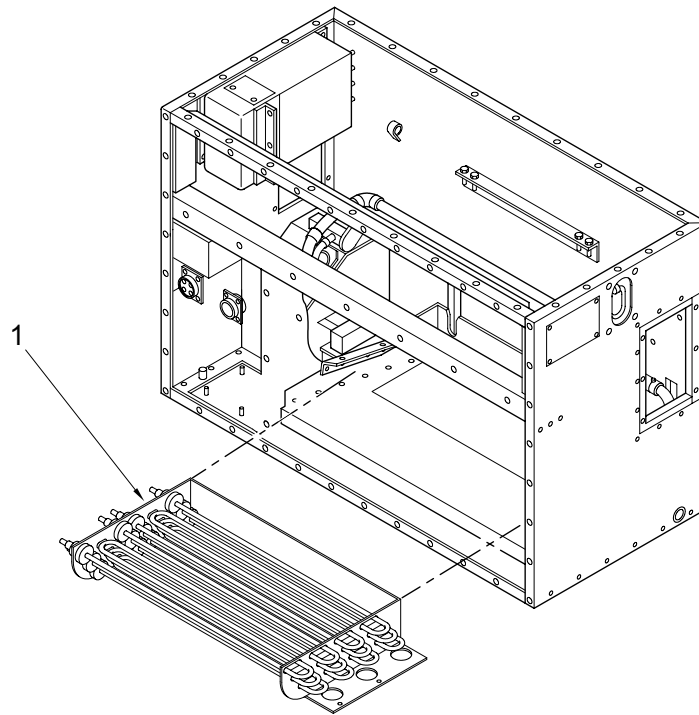

Figure 1. HEATER ASSEMBLY.

REMOVAL

1. Remove the four screws from the mounting bracket flanges.
2. Carefully lift the heater assembly (1) up and out front of the unit.

DISASSEMBLY

NOTE

The following disassembly instructions cover removal of only one heater element. Should more than one or all of the elements have to be removed, repeat steps listed for each heater to be removed.

1. Remove nut from threaded end of heater. Tag wiring to be removed for each terminal.
2. Carefully slip nut, lockwasher, and washers over and off of leads.
3. Slip heater far enough to pull leads through heater mounting hole. Take care that leads are not damaged if heater is to be reinstalled.

4. Slip heater to the side and pull it away from the bracket hole.
5. If mounting bracket is to be replaced, remove all six heaters.

ASSEMBLY

1. Slip the smooth end of the heater through the hole far enough that leads can be placed through the matching hole on the opposite side of the bracket.
2. Carefully slide the leads and the threaded end of the heater into the matching hole in the far end of the bracket.
3. Carefully slip the washers, lockwasher, and nut over the leads and onto the threaded heater end. Refer to tags applied during removal and wiring diagram.
4. Secure the heater nut. Remove tags.

INSTALLATION

1. Carefully slip the heater assembly down into the unit.
2. Secure the heater assembly to the flanges of the evaporator coil with screws.
3. Install blower and motor assembly (See WP 0017 00, EVAPORATOR BLOWER AND MOTOR ASSEMBLY).

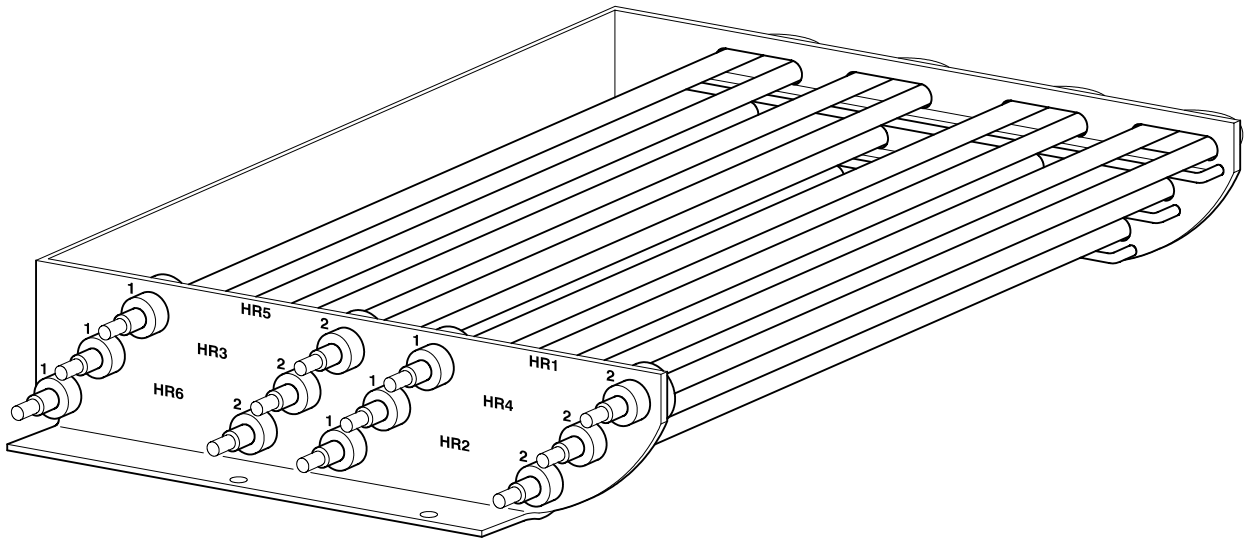

Figure 2. HEATER ELEMENT - TEST.

TESTING

1. Remove heater wiring harness connector P7 from connector J7 on relay assembly.
2. Using multimeter, measure resistance between element terminals as follows:

Table 1. Element Test Table.

FROM TERMINAL	TO TERMINAL	RESISTANCE MEASUREMENT
HR1-T1	HR1-T2	6 TO 10 OHMS
HR2-T1	HR2-T2	6 TO 10 OHMS
HR3-T1	HR3-T2	6 TO 10 OHMS
HR4-T1	HR4-T2	8 TO 12 OHMS
HR5-T1	HR5-T2	8 TO 12 OHMS
HR6-T1	HR6-T2	8 TO 12 OHMS

3. If any of the above tests show a failure, replace heater element.
4. Install top evaporator cover. (See WP 0019 00, EVAPORATOR COVERS).
5. Connect power.

END OF WORK PACKAGE

FIELD LEVEL

24,000 BTUH, SPLIT PACK ENVIRONMENTAL CONTROL UNIT (ECU)

NSN 4120-01-516-4715
F24H4-2

EVAPORATOR BLOWER AND MOTOR ASSEMBLY

0017 00

INITIAL SETUP:

Relay Assembly 178K0163-1
Motor, AC 500K2610

Personnel Required

Field Level Technician (2)

Overheat Switch Assembly 178K0084-1
DC Converter 500T2662

Tools And Special Tools

Tool Kit, Refrigeration Ordnance
5180-00-596-1474

Equipment Condition

Environmental Control Unit removed from
shelter (See
WP 0005 00, INSTALLATION SITE
PREPARATION)
Top evaporator cover removed
Power disconnected

Materials/Parts

Blower Frame 178K0164-1
Impeller, Right 500K2441
Impeller, Left 500K2495
Shaft, Extension 13219E9561-5
Transformer 500K2602
Circuit Board 001T0136-1

References

TM9-4120-429-24P

INSPECTION

1. Check that fan inlet is not damaged. Replace if it is bent, badly dented, or cracked.
2. Check that fan inlet hardware is in place and secure.
3. Check that impeller is in good condition. Replace if it is out of round, dented, broken, or if the hub is loose.
4. Check to see that the setscrew is not missing.
5. After the impellers are installed, check to see that the rotation is correct.
6. Check that blower housing is not damaged. Replace if it is bent, badly dented, or cracked.
7. Check that housing hardware is in place and secure.
8. Check that extension shaft is straight and not cracked or broken. Replace if damaged.
9. Check that shaft is free of nicks and rough edges. Using abrasive cloth or hand file, dress smaller nicks and rough edges or burrs off of shaft. Replace if sanding or filing cannot remove nick.

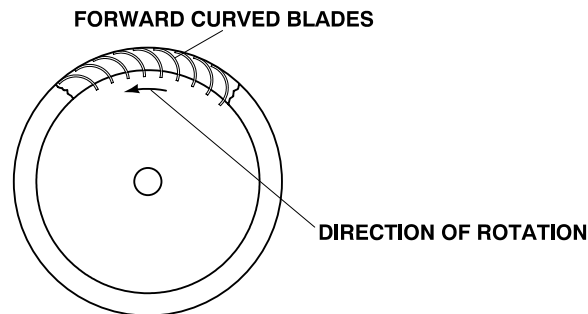

Figure 1. FAN IMPELLER DIRECTION OF ROTATION.

10. Check that setscrews are not lost. Replace if missing.
11. Check that base is not bent, dented, cracked or punctured. Replace if damaged.
12. Check that blind rivet nuts (rivnuts) are secure and threads not damaged. Replace the ones that are loose or damaged.
13. Check motor to see that it rotates freely without excessive lateral end play.
14. Check motor for visible evidence of overheating.
15. Check connector plug J5/P5 for loose, damaged, or missing pins.

TESTING

WARNING



Disconnect input power to the Environmental Control Unit before performing any Maintenance to the electrical system. Voltages used can be lethal. The Evaporator circuit breaker does not disconnect power to the various components of the Environmental Control Unit.

1. Remove connector plug P5 from connector J5.
2. Using multimeter, check for continuity on P5 between pins 5 and 6.
3. Using multimeter, check resistance of 3 phase motor windings at P5, pins 1 to 2, 2 to 3, 1 to 3. Each resistance should be above zero, but below 12 ohms.
4. If motor fails any of the above tests, replace it. If motor passes all of the tests above, check wiring connections between J5 and K1. (See WP 0045 00, WIRING DIAGRAM).

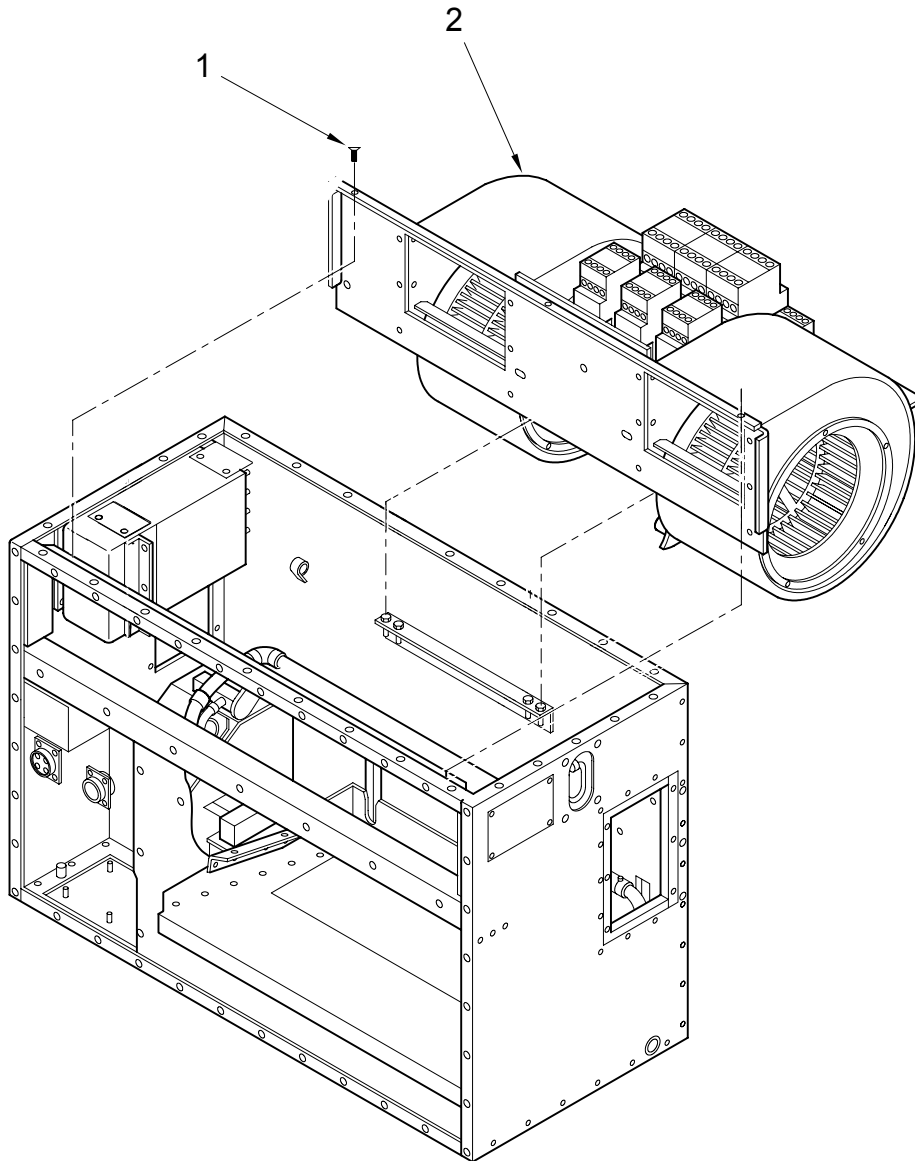

Figure 2. EVAPORATOR BLOWER AND MOTOR ASSEMBLY - LOCATION

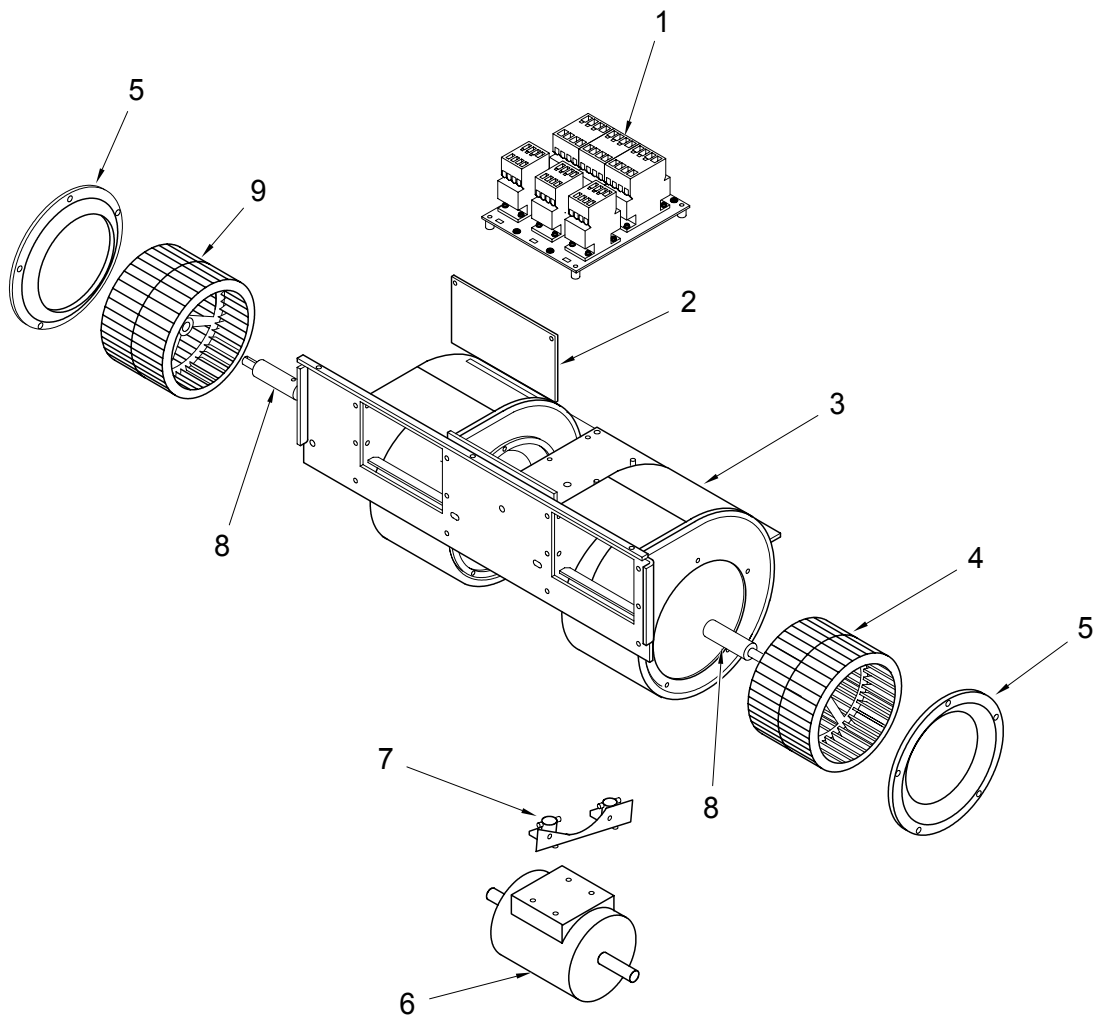

Figure 3. EVAPORATOR BLOWER AND MOTOR ASSEMBLY - COMPONENTS

EVAPORATOR BLOWER AND MOTOR ASSEMBLY COMPONENTS

1. Relay assembly
2. Circuit Card Assembly (PC2)
3. Blower frame
4. Impeller right
5. Inlet ring
6. Motor alternating current
7. Overheat switch assembly and bracket
8. Shaft extension
9. Impeller left

REMOVAL

1. Disconnect connectors (J5/P5, J6/P6, J7/P7, J8/P8, J9/P9) from the relay assembly and (J101, J102, J104, J105, J106 and J108) from circuit card assembly PC2.
2. Remove the screws (1) securing the front face of the blower and motor assembly (2) to the evaporator housing. See Figure 1.
3. Support the evaporator blower and motor assembly and remove the remaining screws, from the rear shelf area. See Figure 1.
4. Carefully lift the evaporator blower and motor assembly up and out of the unit.
5. Remove the relay assembly (1). See Figure 2.
6. Remove screws and washers from outer impeller inlet ring.
7. Remove the outer fan inlet ring (5).
8. Remove the screws and washers from the overheat switch assembly (7).
9. Move the overheat switch assembly (7) out of the way.
10. Loosen the setscrews in the extension shaft (8).
11. Slip the impeller (4) or (9) and extension shaft (8) out of the blower housing. If both impellers are to be removed, mark or tag them to avoid reversing the impellers.
12. Remove the screws and locknuts from the blower housing.
13. Remove the blower housing (3) from the mounting plate.
14. Loosen the impeller setscrew.
15. Slip the impeller (4) or (9) off the extension shaft (8). If the impeller does not come off the shaft easily, do not hit or twist the impeller. Impellers are easily damaged. Secure the free end of the extension shaft in a vise or similar tool. Use a screwdriver through the impeller setscrew access opening, and place tip between impeller hub and extension shaft shoulder and twist screwdriver.
16. If the extension shaft on the other impeller is to be removed, go back to step 12.
17. Note position of rotation arrow on motor (for installation).
18. Remove cap screws, lockwashers, and flat washers, and carefully remove the motor from the base.

REPAIR OR REPLACEMENT

1. Minor bends or dents in base can be repaired using standard sheet metal practices.
2. Blind rivet nuts (rivnuts) can be replaced by drilling the old one out with a drill slightly smaller than the body diameter of the old nut. Then install a new one.
3. Repair of the evaporator fan motor is limited to the replacement of the electrical connector. For further information on electric motor repair, refer to FM 20-31 (Electric Motor and Generator Repair)

INSTALLATION

1. Be sure the motor rotation is correct. (See Removal, step 11)
2. Carefully slip motor into place.
3. Secure the motor (6) to the base with cap screws, lockwashers, and flat washers.
4. Align impeller setscrew with flat surface on extension shaft.

5. Slip impeller (4) or (9) on extension shaft (8) as far as possible and tighten setscrew.
6. Be sure that the direction of rotation arrows on motor and fans agree. Take care that impellers are not reversed.
7. Install inner fan inlet rings to housings with screws and flat washers.
8. Secure the blower housings (3) to the base with screws and locknuts.
9. Slip impeller (4) or (9) and extension shaft (8) assembly on motor shaft.
10. Check to see that the impellers are located an equal distance between the two walls of the blower housing.
11. Tighten the extension shaft setscrews.
12. Spin the impeller by hand to check for interference.
13. Install the outer fan inlet rings (5) and secure each with screws and washers.
14. Carefully lower the evaporator blower and motor assembly (2) down into the unit and align the holes.
Figure 2
15. Secure with cap screws, lockwashers, and flat washers.
16. Place the relay assembly in position and align the mounting screws.
17. Secure the mounting screws.
18. Connect the relay assembly connectors (J5/P5, J6/P6, J7/P7, J8/P8, J9/P9) and circuit card assembly PC2 connectors (J101, J102, J104, J105, J106 and J108).
19. Install top evaporator cover.

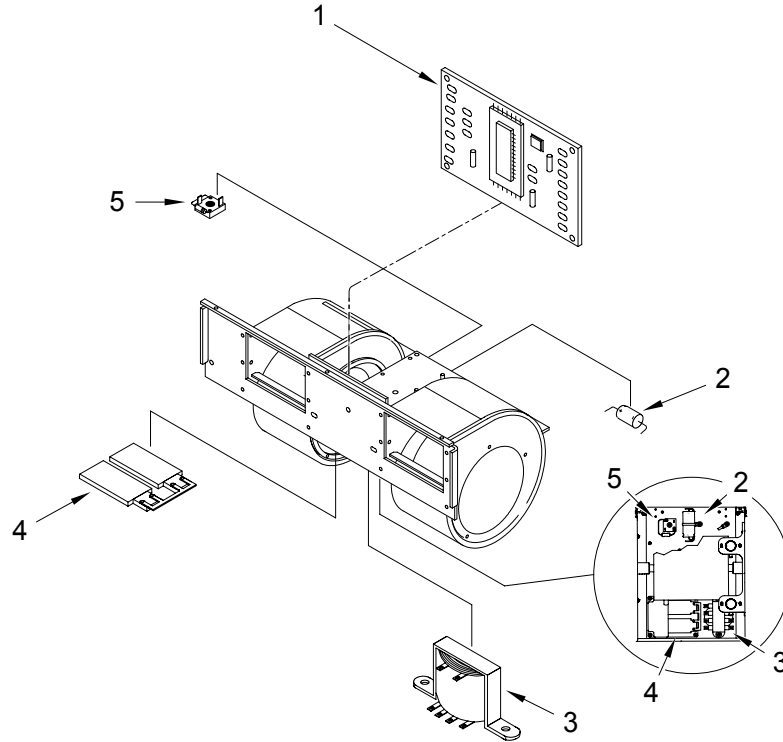

Figure 4. PRINTED CIRCUIT BOARD.

INSPECTION**NOTE**

The Circuit Card Assembly can be replaced without removing the blower assembly.

1. Check that circuit board (1) is not bent, cracked, or burnt. Replace if damaged.
2. Check that wires to terminals, plugs and receptacles are not broken, cut, loose, or missing. Repair if damaged.
3. Referring to WP 0045 00, WIRING DIAGRAM, check that unit energizes when appropriate selection is selected on the remote control unit. Refer to malfunction index if unit fails to engage.
4. Check that cable and harness connections are tight.
5. Check for accumulated dirt and mildew. Clean if necessary.

REMOVAL

1. Remove and label each wire from terminals, plugs and receptacles.
2. Remove screws securing circuit card assembly to the blower assembly. Retain hardware for installation.
3. Remove the circuit card assembly.

INSTALLATION

1. Refer to WP 0045 00, WIRING DIAGRAM and tags applied during removal. Attach connectors to terminals, plugs and receptacles as applicable.
2. Remove all tags.
3. Align printed circuit board with slot in mounting plate and secure with screws retained in removal.

TESTING

1. Measure continuity between J101-6 and J105-8.
2. If continuity, replace C1(2), T1 (3), PS1 (4) and CR1/R2 (5). Figure 1 (See WP 0045 00, WIRING DIAGRAM)
3. If no continuity, replace circuit card assembly.

NOTE

Relays can be replaced without removing mounting plate from atop the blower assembly

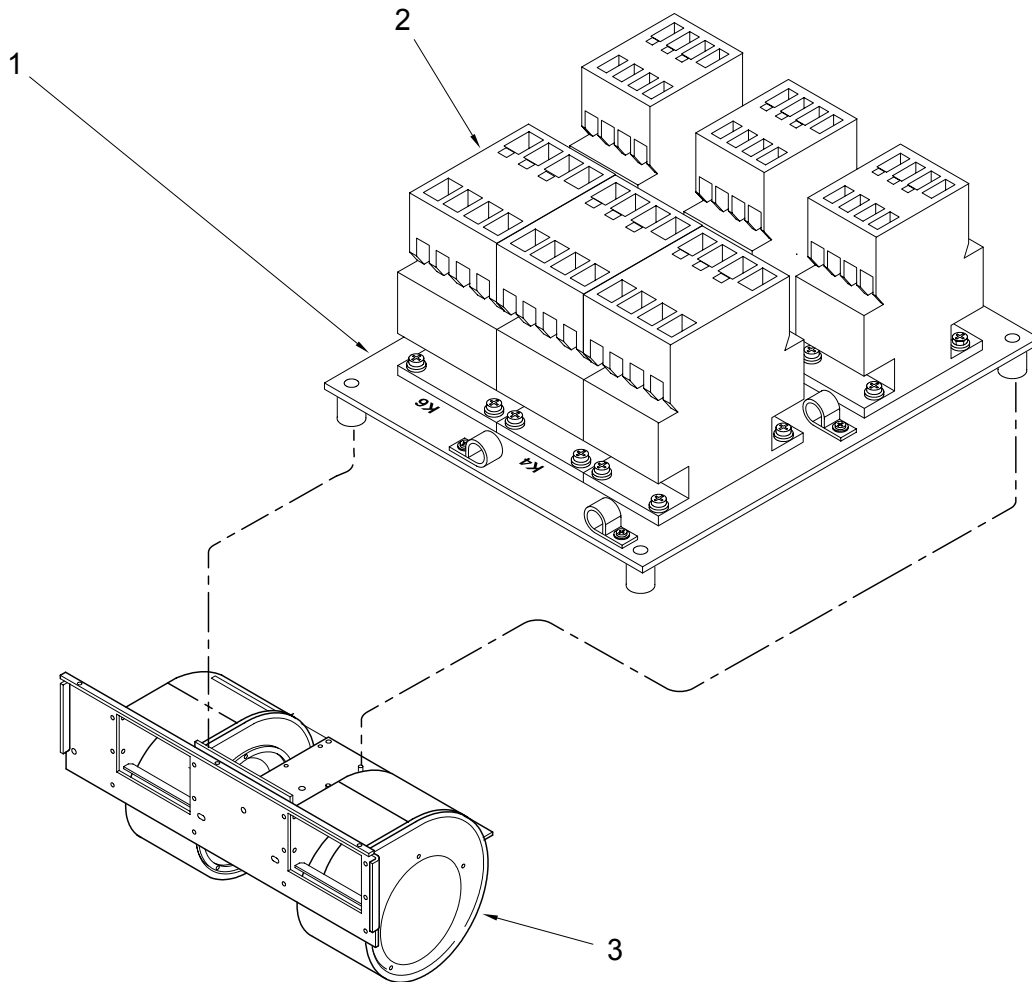

Figure 5. RELAY ASSEMBLY.

NOTE

It is not necessary to remove blower and motor assembly (3) for relay inspection.

INSPECTION

1. Check that the relays (2) are not cracked or burnt. Replace if damaged.
2. Check wires to the relay terminals are not broken, cut, loose, or missing. Repair if damaged.
3. Referring to WP 0045 00, WIRING DIAGRAM, check that relays energize when appropriate selection is selected on the remote control unit. Replace if relay fails to engage.
4. Check that cable and harness connections are tight.
5. Check for accumulated dirt and mildew. Clean if necessary.

REMOVAL

1. Remove and label each wire from screw terminals on the affected relay.
2. Remove screws securing relay to the mounting plate (1). Retain hardware for installation.
3. Remove the affected relay.

INSTALLATION

1. Align relay with holes in mounting plate (1) and secure with screws retained in removal.
2. Refer to WP 0045 00, WIRING DIAGRAM and tags applied during removal. Attach wiring to the terminals.
3. Remove all tags.
4. Test relay for operation.

END OF WORK PACKAGE

FIELD LEVEL

24,000 BTUH, SPLIT PACK ENVIRONMENTAL CONTROL UNIT (ECU)

NSN 4120-01-516-4715
F24H4-2

VARIABLE FREQUENCY DEVICE (VFD)

0018 00

INITIAL SETUP:

Personnel Required

Field Level Technician (2)

Front cover removed (See WP 0019 00,
EVAPORATOR ACCESS AND FRESH AIR
COVERS)

Tools And Special Tools

Tool Kit, Refrigeration Ordnance
5180-00-596-1474

Top cover removed (See WP 0019 00,
EVAPORATOR COVERS)

Blower and motor assembly removed (See WP
0017 00, EVAPORATOR BLOWER AND
MOTOR ASSEMBLY)

Materials/Parts

Variable Frequency Drive 500T2504
Mount 6821-4
Bracket 178K0083-1

References

TM 9-4120-429-24P

Equipment Condition

ECU removed from shelter (See WP 0005 00,
INSTALLATION SITE PREPARATION)

INSPECTION

1. Visually inspect the VFD for broken or loose parts and signs of excessive heat. See Figure 1.
2. If damage is observed, replace the VFD.

REMOVAL

1. Remove screws (1) located on bottom of the evaporator that secures the VFD assembly (2) in place. See Figure 2.
2. Disconnect wiring from L1, L2 and L3 and T1, T2 and T3 terminal strips. Tag wiring for correct placement during reinstallation.
3. Carefully remove the VFD assembly (2) through the front of the evaporator. See Figure 2.
4. Remove screws and separate the VFD from the mounting plate. Retain the plate and screws for reinstallation.

INSTALLATION

1. Attach the VFD to the mounting plate retained in removal.
2. Insert the VFD assembly (2) through the front of the evaporator assembly. See Figure 2.
3. Connect wiring to L1, L2 and L3 and T1, T2 and T3 terminal strips. Refer to tags and wiring diagram (See WP 0045 00, WIRING DIAGRAMS)
4. Align VFD to mounting holes in bottom of the evaporator.
5. Use screws (1) retained in removal to secure the VFD assembly (2).
6. Replace evaporator covers.

TESTING

1. Test the VFD as described in Operational Checkout and Troubleshooting Procedures. (See WP 0008 00, OPERATIONAL CHECKOUT AND TROUBLESHOOTING PROCEDURES)

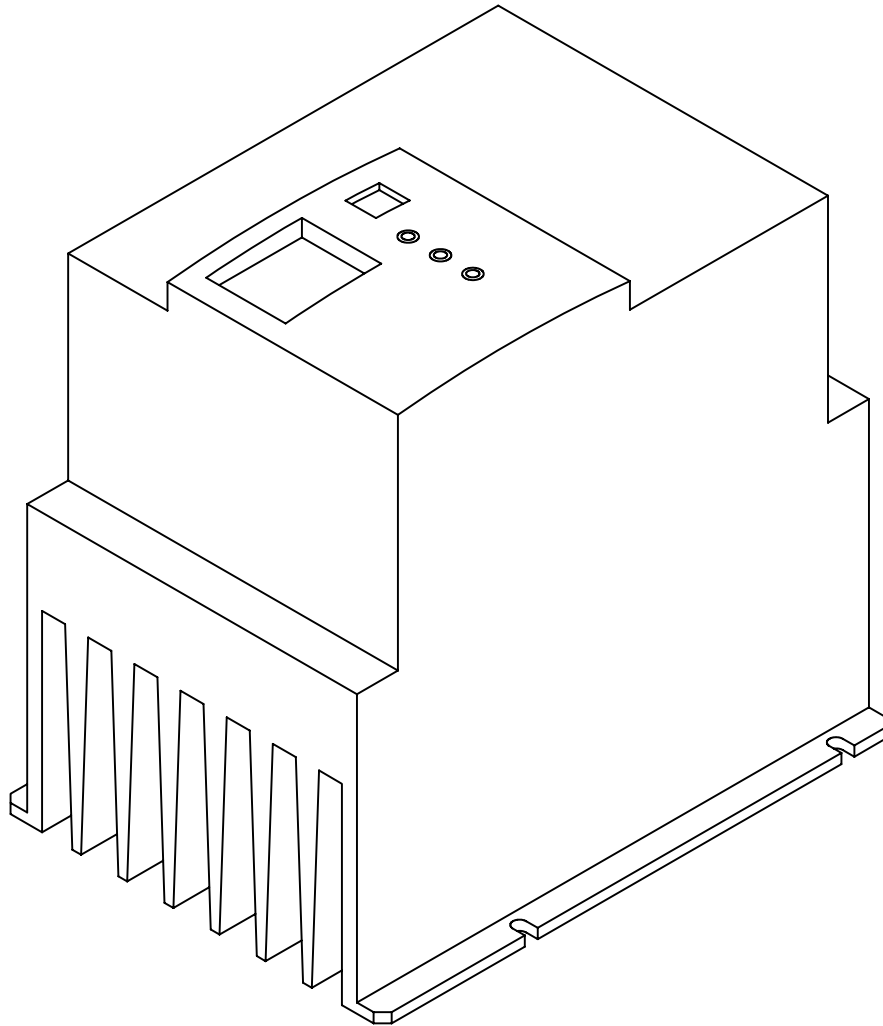

Figure 1. VARIABLE FREQUENCY DEVICE.

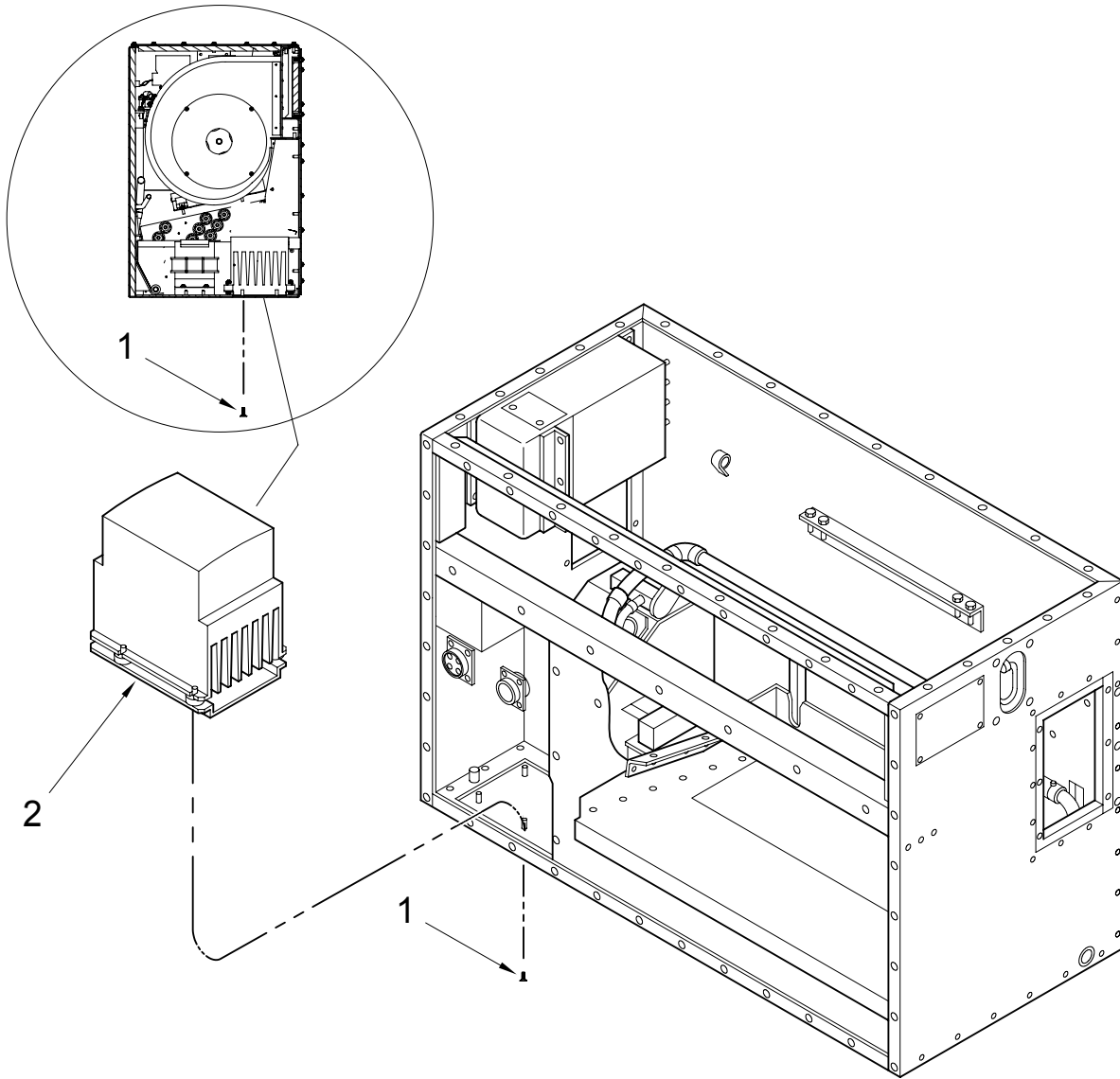

Figure 2. VARIABLE FREQUENCY DEVICE - LOCATION.

END OF WORK PACKAGE

FIELD LEVEL

24,000 BTUH, SPLIT PACK ENVIRONMENTAL CONTROL UNIT (ECU)

NSN 4120-01-516-4715
F24H4-2

EVAPORATOR COVERS

0019 00

INITIAL SETUP:

Access Cover 178K0021

Fresh Air Cover 1321E9486

Tools Personnel Required

Field Level Technician (2)

Adhesive, Sealant 13211E8304

Adhesive EMI 111K1904

Top Evaporator Cover 178K0024

Tools And Special Tools

Tool Kit, Refrigeration Ordnance

5180-00-596-1474

Equipment Condition

ECU turned off at shelter circuit breaker

Materials/Parts

Front Cover Assembly 178K0020-1

References

TM9-4120-429-24P

INSPECTION

1. Check that covers are not bent or punctured. Repair or replace if damaged.
2. Check that EMI gaskets are not cracked, loose, or missing. Repair if damaged.

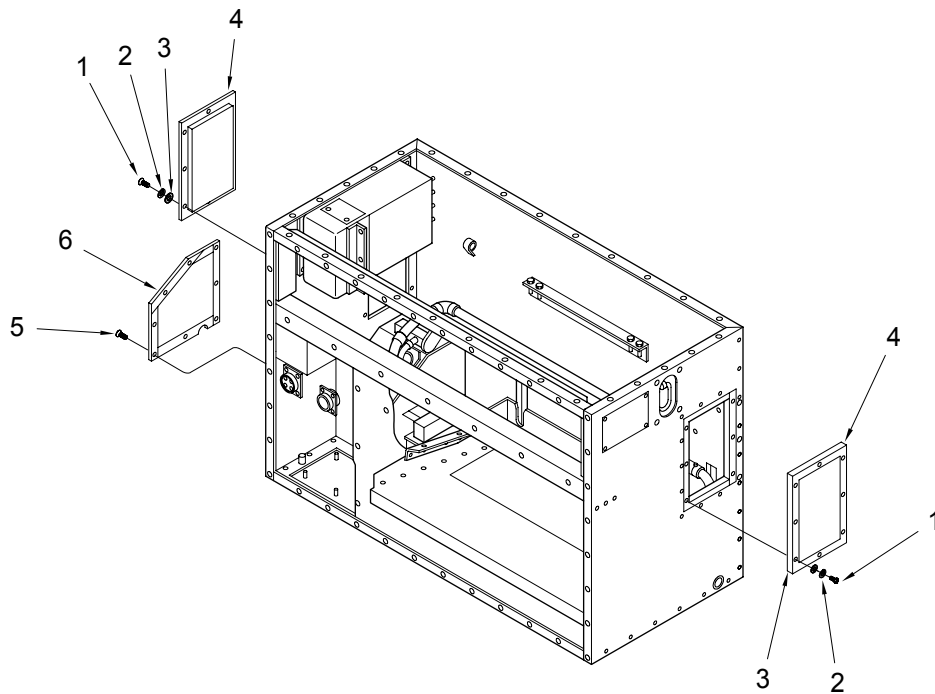

Figure 1. EVAPORATOR ACCESS AND FRESH AIR COVERS.

FRESH AIR COVERS

REMOVAL

WARNING



Disconnect input power to the Environmental Control Unit before performing any maintenance to the electrical system. Voltages used can be lethal. The Evaporator circuit breaker does not disconnect power to the various components of the Environmental Control Unit.

1. Remove screws (1), lockwashers (2), and flat washers (3) from either fresh air cover (4). See Figure 1.
2. Lift either fresh air cover from the Environmental Control Unit.
3. Remove screws (5) from access cover (6). See Figure 1.
4. Carefully remove the access cover (6).

NOTE

Prior to removal of old gasket material or insulation, cut the new replacement material to size using the old item as a sample.

5. Remove as much old gasket or insulation material as possible by pulling or scraping it away from the metal surface.

WARNING



Dry Cleaning Solvent is flammable, and its vapors can be explosive. Repeated or prolonged skin contact or inhalation of vapors can be toxic. Use a well-ventilated area, and keep away from sparks or flame. Use goggles, gloves, and apron when appropriate.

6. Soften and remove old adhesive and gasket residue, using dry cleaning solvent and a stiff brush.
7. Minor dents and bent edges can be straightened using common sheet metal repair procedures. Panels that are badly dented, bent, or punctured should be replaced.
8. Should touch up or refinishing be necessary, see WP 0044 00, FINISH REPAINTING AND REFINISHING GENERAL .
9. EMI gasket material specified for this unit is supplied with adhesive backing.
10. Cut gasket to size. Be sure that EMI gasket corners are mitered so that good continuous edge contact is made.
11. Be sure that surface to which gasket is to be applied is clean and free of paint and old adhesive material.
12. Remove backing material from adhesive side and immediately press gasket in place. Be sure that good edge-to-edge contact is made on the EMI gaskets.
13. Cut insulation to size.
14. Ensure that the surface to which the insulation is to be applied is clean and free of paint and old adhesive material.
15. Coat the mating surfaces of the metal and the insulation with adhesive. Let both surfaces air dry until the adhesive is tacky but will not stick to the fingers.
16. Starting with an end, carefully attach the insulation to the metal. Press into firm contact all over.

INSTALLATION

1. Line up screw holes in access cover (6) and Environmental Control Unit Housing. See Figure 1.
2. Install cover with screws (5).
3. Line up screw holes in fresh air cover (4) and Environmental Control Unit housing.
4. Install cover with screws (1), lockwashers (2), and flat washers (3). See Figure 1.
5. Connect power cable at access panel and turn Environmental Control Unit on.

TOP COVER

INSPECTION

1. Check that top cover (1) is not bent or punctured. Replace if damaged.
2. Check that EMI and other gaskets and insulation are not cracked, loose, or missing. Replace if damaged.
3. Check that data plate is readable and in place. Replace if damaged.

REMOVAL

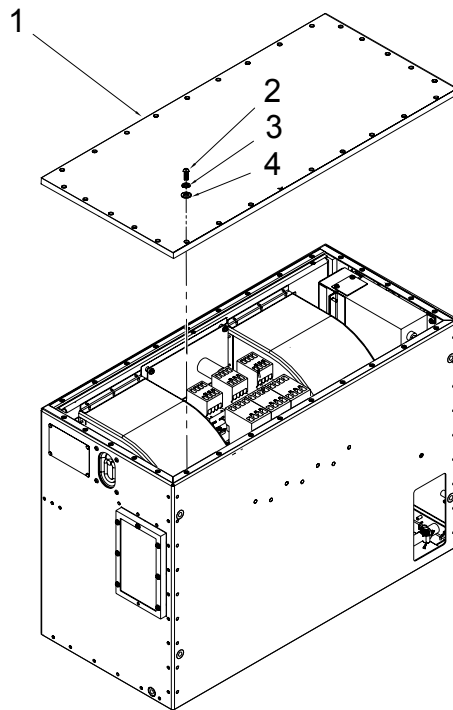

Figure 2. EVAPORATOR TOP COVER.

WARNING

Disconnect input power to the Environmental Control Unit before performing any maintenance to the electrical system. Voltages used can be lethal. The Evaporator circuit breaker does not disconnect power to the various components of the Environmental Control Unit.

1. Remove screws (2), lockwashers (3), and flat washers (4). See Figure 2.
2. Carefully lift the top cover (1) from the Environmental Control Unit.

REPAIR OR REPLACEMENT**NOTE**

Prior to removal of old gasket material or insulation, cut the new replacement material to size using the old item as a sample.

1. Remove as much old gasket or insulation material as possible by pulling or scraping it away from the metal surface.

WARNING

Dry Cleaning Solvent is flammable, and its vapors can be explosive. Repeated or prolonged skin contact or inhalation of vapors can be toxic. Use a well-ventilated area, and keep away from sparks or flame. Use goggles, gloves, and apron when appropriate.

2. Soften and remove old adhesive and gasket residue, using dry cleaning solvent and a stiff brush.
3. To replace danger plate, use a drill bit slightly smaller than the diameter of the rivet being removed.
4. Drill the rivets out and remove the old plate.
5. Align holes in replacement part and cover and install new rivets.
6. Minor dents and bent edges can be straightened using common sheet metal repair procedures. Panels that are badly dented, bent, or punctured should be replaced.
7. Should touch up or refinishing be necessary, see WP 0044 00, FINISH REPAINTING AND REFINISHING GENERAL.

8. EMI gasket material specified for this unit is supplied with adhesive backing.
9. Cut gasket to size. Be sure that EMI gasket corners are mitered so that good continuous edge contact is made.
10. Be sure that surface to which gasket is to be applied is clean and free of paint and old adhesive material.
11. Cut insulation to size (See WP 0014 00, EVAPORATOR HOUSING ASSEMBLY).
12. Be sure that the surface to which the insulation is to be applied is clean and free of paint and old adhesive material.
13. Coat the mating surfaces of the metal and the insulation with adhesive. Let both surfaces air dry until the adhesive is tacky but will not stick to the fingers.
14. Starting with an end, carefully attach the insulation to the metal. Press into firm contact all over.

INSTALLATION

1. Line up screw holes in cover and Environmental Control Unit housing. See Figure 2.
2. Install cover with screws.
3. Install Environmental Control Unit on shelter.
4. Connect power cable at access panel and turn Environmental Control Unit shelter circuit breaker on.

INSPECTION

1. Check that cover is not bent or punctured. Replace if damaged.
2. Check that EMI and other gaskets and insulation are not cracked, loose, or missing. Replace if damaged.
3. Check EMI screens are not bent or punctured. Replace if damaged. See Figure 3.
4. Check that danger plate is readable and in place. Replace if damaged (See WP 0002 00, DECALS AND INSTRUCTION PLATES).

REMOVAL

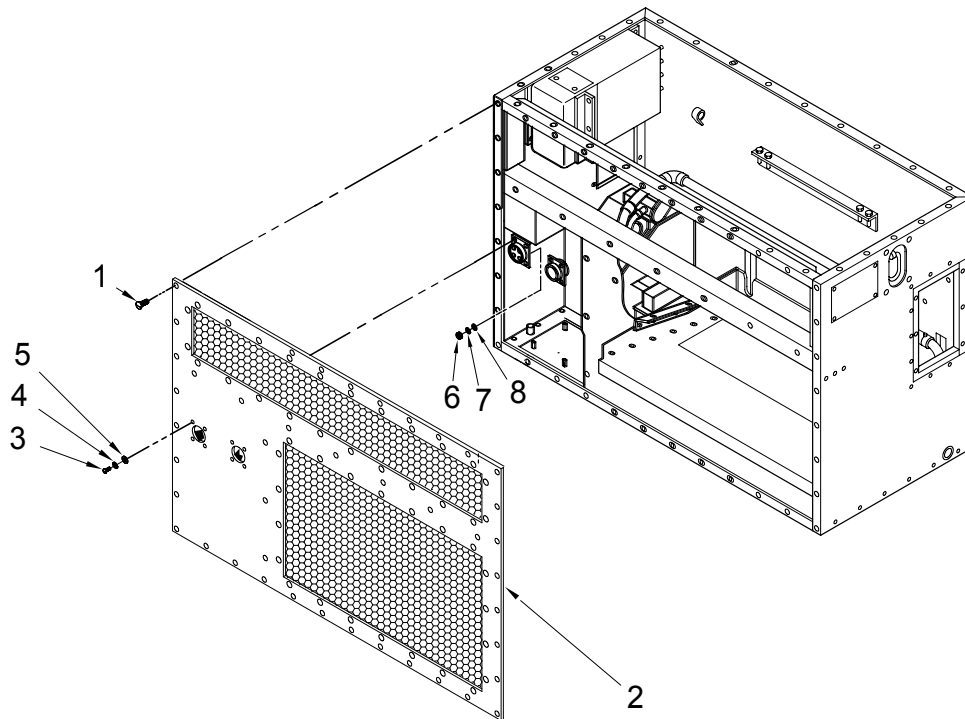

Figure 3. EVAPORATOR ASSEMBLY FRONT COVER.

WARNING

Disconnect input power to the Environmental Control Unit before performing any maintenance to the electrical system. Voltages used can be lethal. The Evaporator circuit breaker does not disconnect power to the various components of the Environmental Control Unit.

CAUTION

Exercise care that EMI screens are not damaged during removal of front cover assembly.

1. Remove screws (1), front cover. Retain screws and washers for installation. See Figure 3.
2. Carefully separate the front cover from the Environmental Control Unit using care not to damage wiring.
3. Remove screws (3), lockwashers (4), flat washers (5) and nuts(6), lockwashers (7) and flat washers (8) from connector J1 and J2. Retain screws, washers and nuts for installation. Remove connectors J1, J2 and ground wires from cover. See Figure 3.
4. Remove front cover.

REPAIR OR REPLACEMENT

WARNING



Disconnect input power to the Environmental Control Unit before performing any maintenance to the electrical system. Voltages used can be lethal. The Evaporator circuit breaker does not disconnect power to the various components of the Environmental Control Unit.

NOTE

Prior to removal of old gasket material or insulation, cut the new replacement material to size using the old item as a sample.

1. Remove as much old gasket or insulation material as possible by pulling or scraping it away from the metal surface.
2. Soften and remove old adhesive and gasket residue, using dry cleaning solvent and a stiff brush.
3. To replace data plates, use a drill bit slightly smaller than the diameter of the rivet being removed.
4. Drill the rivets out and remove the old plate.
5. Align holes in replacement part and cover and install new rivets.
6. Minor dents and bent edges can be straightened using common sheet metal repair procedures. Panels that are badly dented, bent, or punctured should be replaced.
7. Should touch up or refinishing be necessary, see WP 0044 00, FINISH REPAINTING AND REFINISHING GENERAL .
8. Use only approved replacement material.
9. EMI gasket material specified for this unit is supplied with adhesive backing.
10. Cut gasket to size. Be sure that EMI gasket corners are mitered so that good continuous edge contact is made.
11. Be sure that surface to which gasket is to be applied is clean and free of paint and old adhesive material.
12. Remove backing material from adhesive side and immediately press gasket in place. Be sure that good edge-to-edge contact is made on the EMI gaskets.

13. Cut insulation to size (See WP 0014 00, EVAPORATOR HOUSING ASSEMBLY).
14. Be sure that the surface to which the insulation is to be applied is clean and free of paint and old adhesive material.
15. Coat the mating surfaces of the metal and the insulation with adhesive. Let both surfaces air dry until the adhesive is tacky but will not stick to the fingers.
16. Starting with an end, carefully attach the insulation to the metal. Press into firm contact all over.

NOTE

When installing connectors, ensure keyways are positioned at the top.

INSTALLATION

1. Insert connectors J1 and J2 in front cover and align mounting holes.
2. Attach connectors J1, J2 and ground wires using screws, washers and nuts retained during removal.
3. Align front cover with mounting holes and install cover with screws and washers retained during removal.
4. Install Environmental Control Unit on shelter (See WP 0005 00, INSTALLATION SITE PREPARATION).
5. Connect power cable at access panel and turn Environmental Control Unit at shelter circuit breaker.

END OF WORK PACKAGE

FIELD LEVEL

24,000 BTUH, SPLIT PACK ENVIRONMENTAL CONTROL UNIT (ECU)

NSN 4120-01-516-4715
F24H4-2

HARMONIC FILTER FL2

0020 00

INITIAL SETUP:

Personnel Required

Field level technician (2)

Tools And Special Tools

Tool Kit, Refrigeration Ordnance
5180-00-596-1474

Materials/Parts

Harmonic Filter 102060
Channel Bracket 178K0325-1

Equipment Condition

ECU removed from shelter (See WP 0005 00,
INSTALLATION SITE PREPARATION)
Top cover removed (See WP 0019 00, EVAPORATOR COVERS)
Blower and motor assembly removed (See WP 0017 00, EVAPORATOR BLOWER AND
MOTOR ASSEMBLY)

References

TM 9-4120-429-24P

INSPECTION

1. Check the harmonic filter housing for physical damage such as dents, punctures, cuts, and ruptured seams. Replace if damaged.
2. Look for evidence of overheating. Replace if overheating is indicated.
3. Check that connectors are secure and contacts are tight and not damaged. Replace if connectors are loose or damaged.

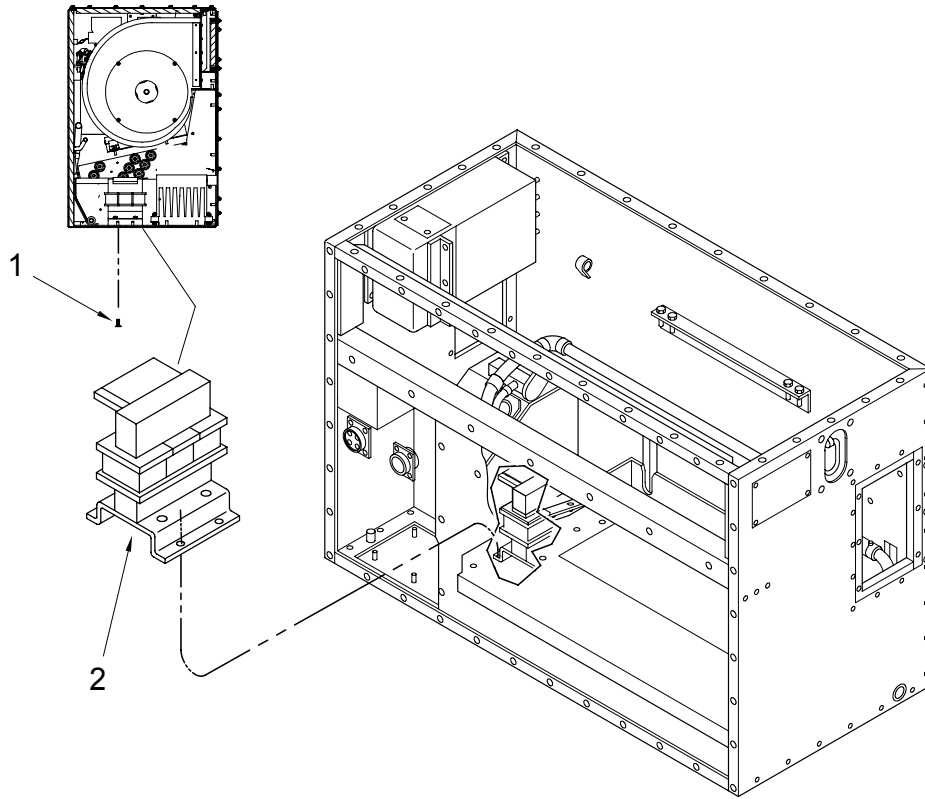

Figure 1. HARMONIC FILTER ASSEMBLY FL2.

REMOVAL

1. Remove screws (1) from the bottom of the evaporator securing the harmonic filter assembly (2). Retain screws for installation. See Figure 1.
2. Disconnect connector J9/P9.
3. Tag and remove wires from A, B and C terminals atop the harmonic filter.
4. Carefully slide the harmonic filter assembly (2) out the top of the evaporator assembly. Figure 1.
5. Measure for continuity between J9-1 and FL2-A1, J9-2 and FL2-B2, and J9-3 and FL2-C2. If continuity is not present, replace the harmonic filter FL2 (See WP 0020 00).
6. Remove screws attaching the harmonic filter to the mounting plate. Retain plate and screws for reinstallation.

FIELD LEVEL

24,000 BTUH, SPLIT PACK ENVIRONMENTAL CONTROL UNIT (ECU)

NSN 4120-01-516-4715
F24H4-2

EVAPORATOR HARNESS ASSEMBLIES

0021 00

INITIAL SETUP:

Personnel Required

Field level technician (2)

Tools And Special Tools

Tool Kit, Refrigeration Ordnance
5180-00-596-1474

Materials/Parts

Wiring Harness 178K0106-1
Wiring Harness 178K0107-1
Wiring Harness 178K0110-1

Equipment Condition

ECU removed from shelter (See WP 0005 00, INSTALLATION SITE PREPARATION)
Access cover removed (See WP 0019 00, EVAPORATOR ACCESS AND FRESH AIR COVERS)
Front cover removed (See WP 0019 00, EVAPORATOR ACCESS AND FRESH AIR COVERS)
Top cover removed (See WP 0019 00, EVAPORATOR ACCESS AND FRESH AIR COVERS)
Power Removed

Reference

TM 9-4120-429-24P

REMOVAL

NOTE

Remove cable clamps and wire ties where necessary. Retain clamps and hardware for installation.

1. To remove the P3 to TB1 wiring harness (1), disconnect the plug P3 from the J3 connector inside the evaporator access compartment. See Figure 1
2. Separate the evaporator from the condenser assembly. (See WP 0012 00, EVAPORATOR/CONDENSER ASSEMBLY - SEPARATION AND RECONNECTION)
3. Tag each wire attached to TB1 in the condenser junction box assembly. Remove wiring from the terminal strip.
4. To remove the J1 to FL1 wiring harness (3), remove screws, washers and nuts from the J1 connector inside the evaporator front cover assembly. Remove the J1 connector. See Figure 1
5. Tag each wire attached to terminals A,B,C, and N in the EMI filter FL1. Remove wiring from the terminals.
6. To remove the J2 to J102 wiring harness (2), remove screws, washers and nuts from the J2 connector inside the evaporator front cover assembly. Remove the J2 connector. See Figure 1
7. Remove P102 from the circuit card assembly PC2 located atop the blower and motor assembly.

REPAIR OR REPLACEMENT

1. See WP 0037 00, ELECTRICAL WIRING REPAIR GENERAL for general wire repair instructions.
2. See wire list for wire lengths and terminal information when individual wires are replaced.

TEST AND INSPECTION

1. Check connectors for general condition, loose, broken, or missing contacts. Replace connectors if damaged.
2. Check individual wires for loose solder connections, cut or frayed insulation, and cut or broken wire.
3. See wiring diagram and continuity test individual wires. Repair or replace wires with no continuity.
4. Check that gaskets are in good condition. Replace them if they are torn, missing or otherwise damaged.

INSTALLATION

1. To install cable harness P3 to TB1 (1), Install wiring in condenser junction box assembly where removed. See wiring diagrams (WP 0045 00, Figure 1). Connect P3 to J3 (See WP 0012 00, EVAPORATOR/CONDENSER ASSEMBLY - SEPARATION AND RECONNECTION) when reconnecting the evaporator and condenser assemblies.
2. To install the J1 receptacle, line up the holes in the gasket, receptacle, and evaporator housing. Install the four screws and locknuts. Reconnect the J1 connector to the receptacle.
3. Route wire and connect to terminals on the EMI filter FL1. Replace hardware and tighten.

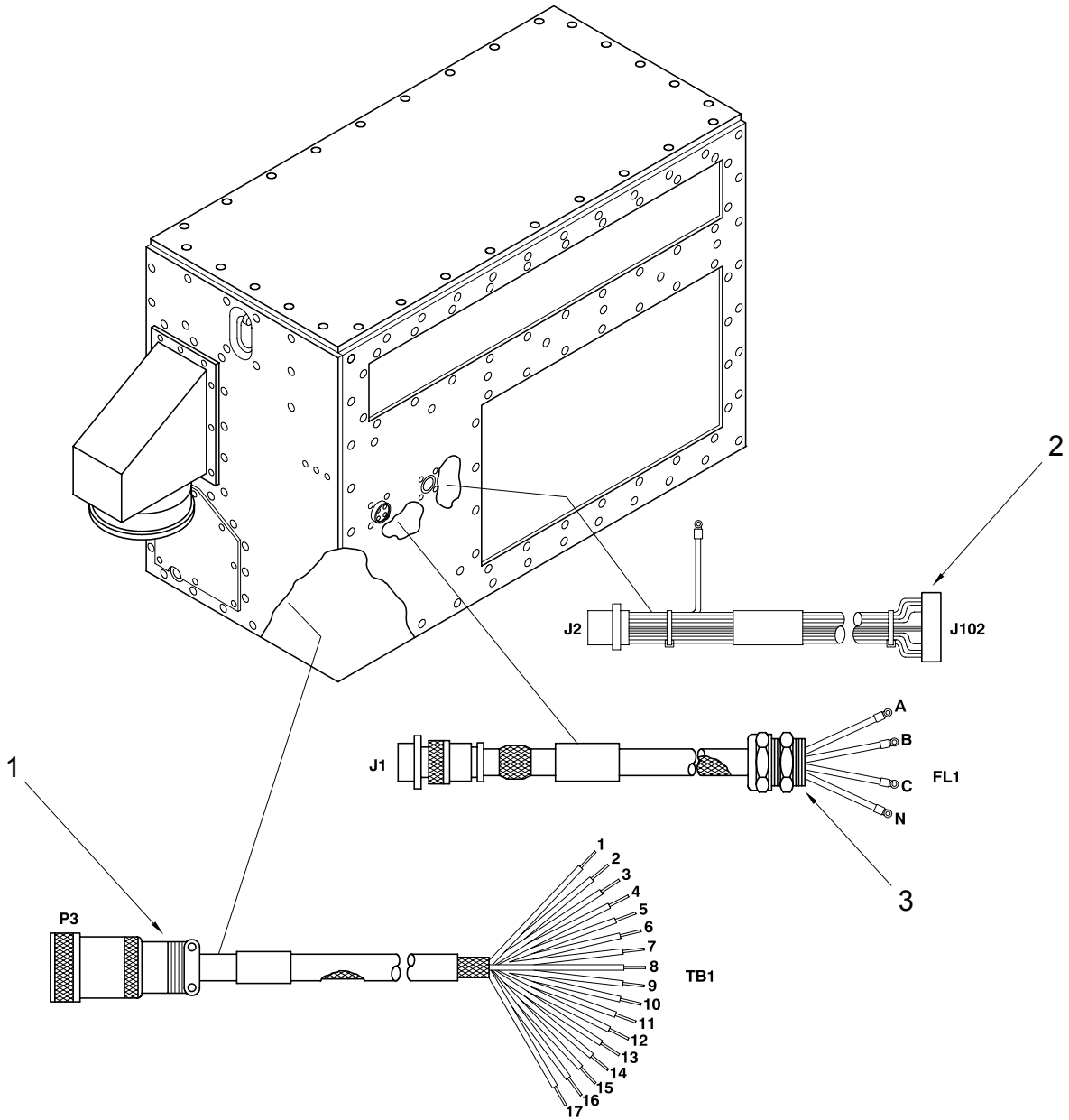

Figure 1. EVAPORATOR HARNESS ASSEMBLIES

4. To install the J2 receptacle, line up the holes in the gasket, receptacle, and evaporator housing. Install the four screws and locknuts. Reconnect the J2 connector to the receptacle.
5. Route cable harness and connect P102 to circuit card assembly J102.
6. Install front evaporator cover. (See WP 0019 00, EVAPORATOR ACCESS AND FRESH AIR COVERS)
7. Install top evaporator cover. (See WP 0019 00, EVAPORATOR ACCESS AND FRESH AIR COVERS)
8. Install access cover. (See WP 0019 00, EVAPORATOR ACCESS AND FRESH AIR COVERS)
9. Install ECU on shelter. (See WP 0005 00, INSTALLATION SITE PREPARATION)

END OF WORK PACKAGE

FIELD LEVEL

24,000 BTUH, SPLIT PACK ENVIRONMENTAL CONTROL UNIT (ECU)

NSN 4120-01-516-4715
F24H4-2

EXPANSION (THERMOSTATIC) VALVE

0022 00

INITIAL SETUP:

Personnel Required

Field level technician (2)

Tools And Special Tools

Tool Kit, Refrigeration Ordnance
5180-00-596-1474

Materials/Parts

Valve Regulator System Pressure (500T2418)

Equipment Condition

ECU removed from shelter (See WP 0005 00,
INSTALLATION SITE PREPARATION)

Access cover removed (See WP 0019 00,
EVAPORATOR ACCESS AND FRESH AIR
COVERS)

Top cover removed (See WP 0019 00,
EVAPORATOR ACCESS AND FRESH AIR
COVERS)

References

TM 9-4120-429-24P

INSPECTION

1. Inspect for evidence of leaks, kinked or otherwise damaged capillary line, and loose or missing valve stem cap.
2. Check sensing bulb (1) to see that it is secured to the compressor inlet suction line. See Figure 1.
3. If a leak is suspected or indicated, test per WP 0040 00, LEAK TESTING THE REFRIGERANT R-410A SYSTEM .

REMOVAL

1. Remove insulation from compressor inlet tube to detach sensing bulb (1). See Figure 1.
2. Remove the screw (3), lockwasher (2), locknut (5), and clamp (4) that secures thermostatic valve (6) to the housing. See Figure 1.
3. Discharge the Refrigerant R-410A system per WP 0041 00, EVACUATING THE REFRIGERANT R-410A SYSTEM.
4. Wrap wet rags around thermostatic valve body, if it is to be reinstalled.
5. While purging the system with nitrogen, apply heat and separate the tubing. (See WP 0043 00, BRAZING/DEBRAZING PROCEDURES).
6. Remove thermostatic valve from unit.

INSTALLATION

1. Position thermostatic valve in unit.
2. Wrap wet rags around thermostatic valve body.
3. While purging the system with nitrogen, braze the tubing joints.
4. Secure sensing bulb to compressor inlet suction line with insulation. Apply in spiral with overlapping edges. Be sure sensing bulb is making good metal-to-metal contact with compressor inlet suction line.

0022 00-1

5. Coil excess capillary tubing above thermostatic valve.
6. Secure thermostatic valve to housing with screw (3), lockwasher (2), locknut (5), and clamp (4).
7. Replace the filter-dryer assembly. (See WP 0030 00, FILTER-DRYER REFRIGERANT).
8. Leak test all newly connected joints and those in the repair area. (See WP 0040 00, LEAK TESTING THE REFRIGERANT R-410A SYSTEM).
9. Evacuate and charge the Refrigerant R-410A system. (See WP 0041 00, EVACUATING THE REFRIGERANT R-410A SYSTEM and WP 0042 00, CHARGING THE REFRIGERANT R- 410A SYSTEM).
10. Install covers. (See WP 0019 00, EVAPORATOR ACCESS AND FRESH AIR COVERS).
11. Install ECU on shelter. (See WP 0005 00, INSTALLATION SITE PREPARATION).
12. Connect power.

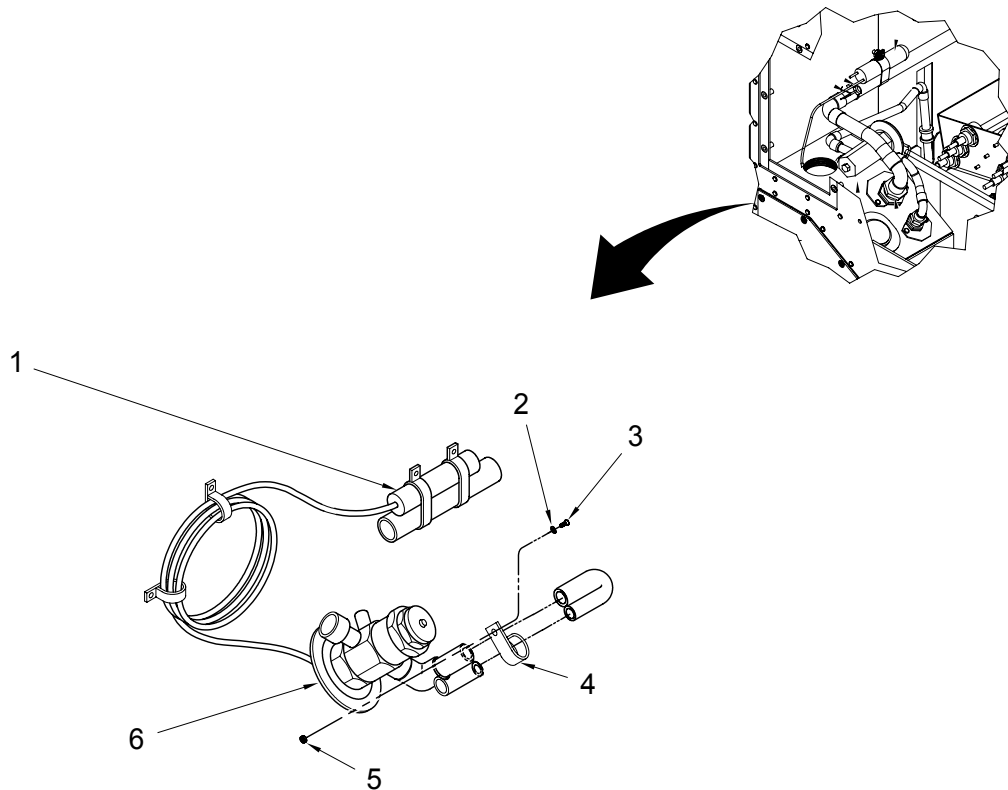

Figure 1. THERMOSTATIC VALVE.

END OF WORK PACKAGE

FIELD LEVEL
24,000 BTUH, SPLIT PACK ENVIRONMENTAL CONTROL UNIT (ECU)
NSN 4120-01-516-4715
F24H4-2

CONDENSER ASSEMBLY

0023 00

INITIAL SETUP:

Personnel Required

Field level technician (2)

Tools And Special Tools

Tool Kit, Refrigeration Ordnance
5180-00-596-1474

Materials/Parts

Condenser Top Cover 178K0026
Dry Cleaning Solvent P-D-680 Type III (1)
Adhesive, Sealant MIL-A-46106 Type I

Equipment Condition

ECU turned off at shelter circuit breaker (See
WP 0008 00, OPERATIONAL CHECKOUT AND
TROUBLESHOOTING PROCEDURES)
Power cable disconnected at access panel (See
WP 0008 00, OPERATIONAL CHECKOUT AND
TROUBLESHOOTING PROCEDURES)
ECU removed from shelter (See WP 0005 00,
INSTALLATION SITE PREPARATION)

References

TM 9-4120-429-24P

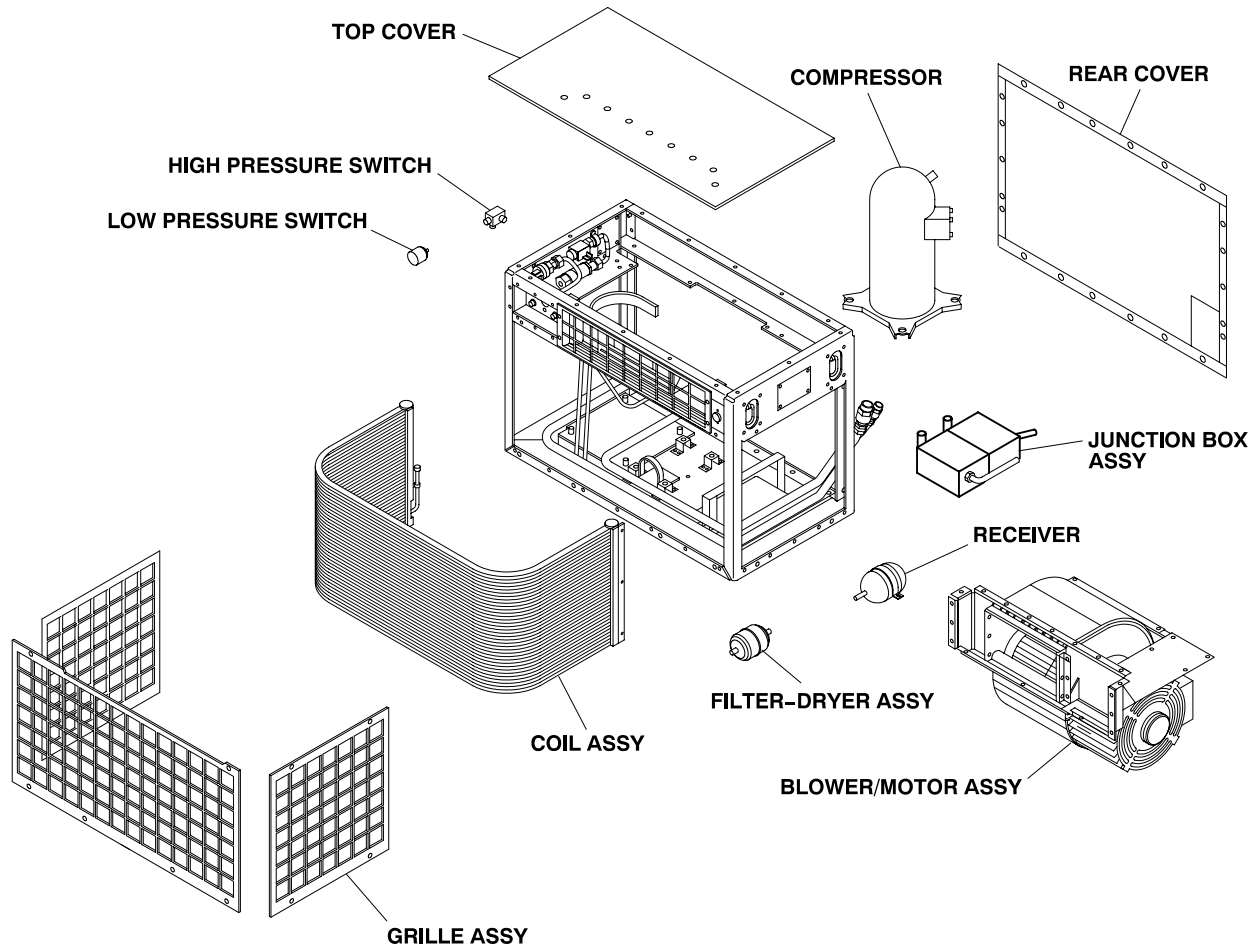

Figure 1. CONDENSER ASSEMBLY.

INSPECTION

1. Check that the rear and top condenser covers are not bent, cracked, or punctured. Replace if damaged.
2. Check that the EMI and other gaskets are not cracked, loose, or missing. Repair if damaged.
3. Check that information plate on top cover is readable and in place. Replace if damaged (See WP 0002 00, DECALS AND IDENTIFICATION PLATES).
4. Check for accumulated dirt and mildew. Clean if necessary.

REMOVAL

1. Remove screws from top condenser cover. See Figure 1.
2. Carefully remove the top condenser cover. See Figure 1.

REPAIR OR REPLACEMENT

NOTE

Prior to removal of old gasket material or insulation, cut the new replacement material to size using the old item as a sample.

WARNING



Dry Cleaning Solvent is flammable, and its vapors can be explosive. Repeated or prolonged skin contact or inhalation of vapors can be toxic. Use a well-ventilated area, and keep away from sparks or flame. Use goggles, gloves, and apron when appropriate.

1. Remove as much old gasket or insulation material as possible by pulling or scraping it away from the metal surface.
2. Soften and remove old adhesive and gasket residue, using dry cleaning solvent and a stiff brush.
3. To remove floating nut plates, use a drill bit slightly smaller than the diameter of the rivet being removed.
4. Drill the rivets out and remove the old plate nut.
5. Align holes in replacement plate nut and cover and install new rivets.
6. To replace information plate, use a drill bit slightly smaller than the diameter of the rivet being removed.
7. Drill the rivets out and remove the old plate.
8. Align holes in replacement plate and cover and install new rivets.
9. Minor dents and bent edges can be straightened using common sheet metal repair procedures. Panels that are badly dented, bent, or punctured should be replaced.
10. Should touch up or refinishing be necessary, see WP 0044 00, FINISH REPAINTING AND REFINISHING GENERAL .
11. EMI gasket material specified for this unit is supplied with adhesive backing.
12. Cut gasket to size. Be sure that EMI gasket corners are mitered so that good continuous edge contact is made.
13. Be sure that surface to which gasket is to be applied is clean and free of paint and old adhesive material
14. Remove backing material from adhesive side and immediately press gasket in place. Be sure that good edge-to-edge contact is made on the EMI gaskets.

INSTALLATION

1. Line up screw holes in top condenser cover.
2. Install cover with screws.
3. Reconnect evaporator and condenser section assemblies. (See WP 0012 00, EVAPORATOR/CONDENSER ASSEMBLY - SEPARATION AND RECONNECTION).
4. Install Environmental Control Unit on shelter. (See WP 0005 00, INSTALLATION SITE PREPARATION).

END OF WORK PACKAGE

FIELD LEVEL

24,000 BTUH, SPLIT PACK ENVIRONMENTAL CONTROL UNIT (ECU)

NSN 4120-01-516-4715
F24H4-2

JUNCTION BOX ASSEMBLY

0024 00

INITIAL SETUP:

Personnel Required

Unit Level Technician (1)

Tools And Special Tools

Tool Kit, Refrigeration Ordnance
5180-00-596-1474

Materials/Parts

Junction Box Assembly 001T0104-1

Equipment Condition

ECU removed from shelter (See WP 0005 00,
INSTALLATION SITE PREPARATION)
Top cover removed (See WP 0025 00,
CONDENSER COVERS)
Power Removed from ECU (See WP 0008 00,
OPERATIONAL CHECKOUT AND
TROUBLESHOOTING PROCEDURES)
Blower and motor assembly removed (See WP
0027 00, CONDENSER BLOWER AND MOTOR
ASSEMBLY)
EVAPORATOR ACCESS COVER REMOVED
(See WP 0019 00)

References

TM 9-4120-429-24P

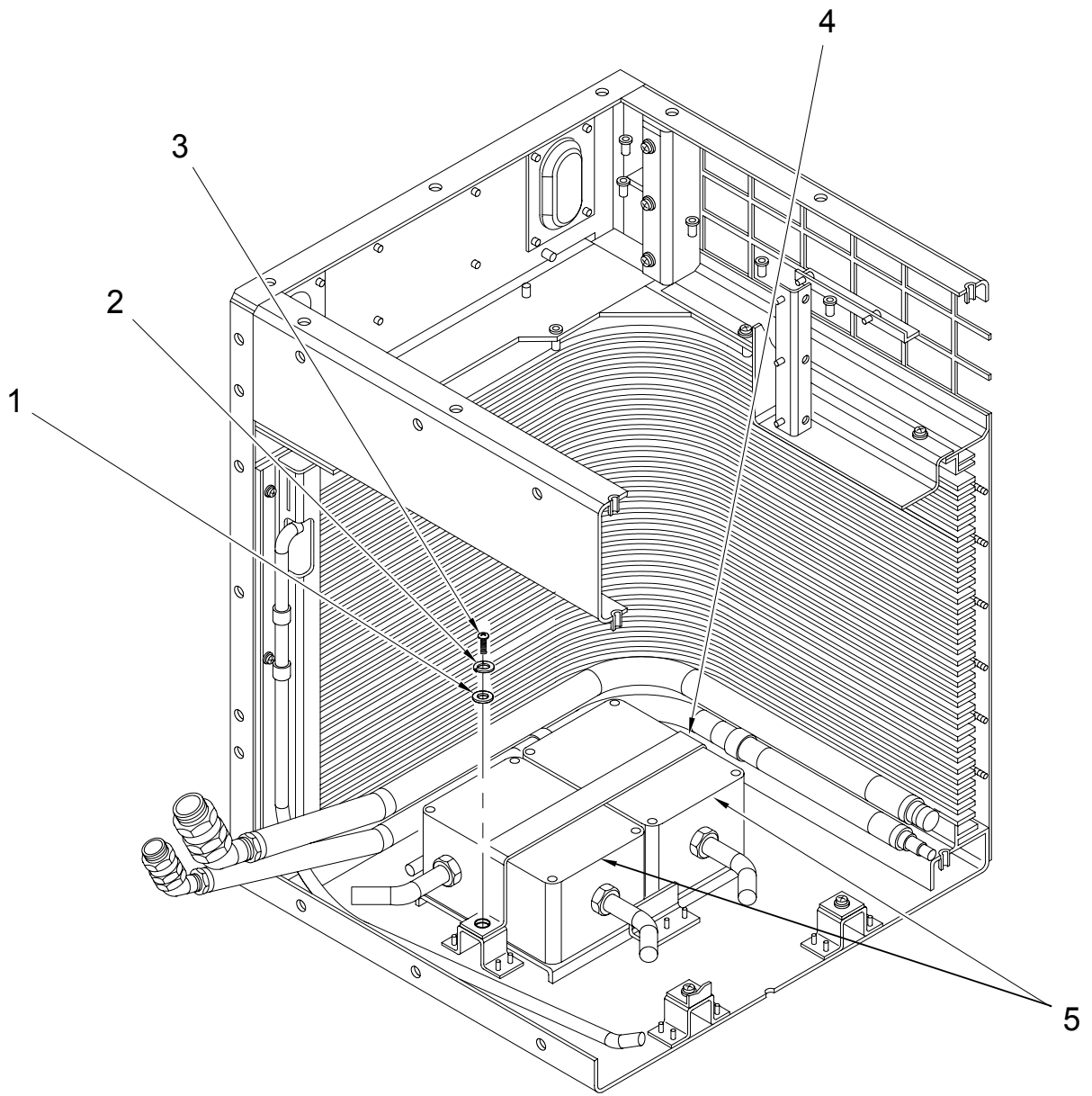
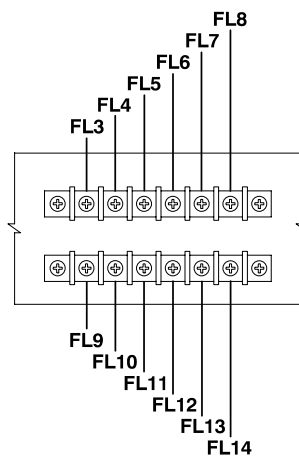
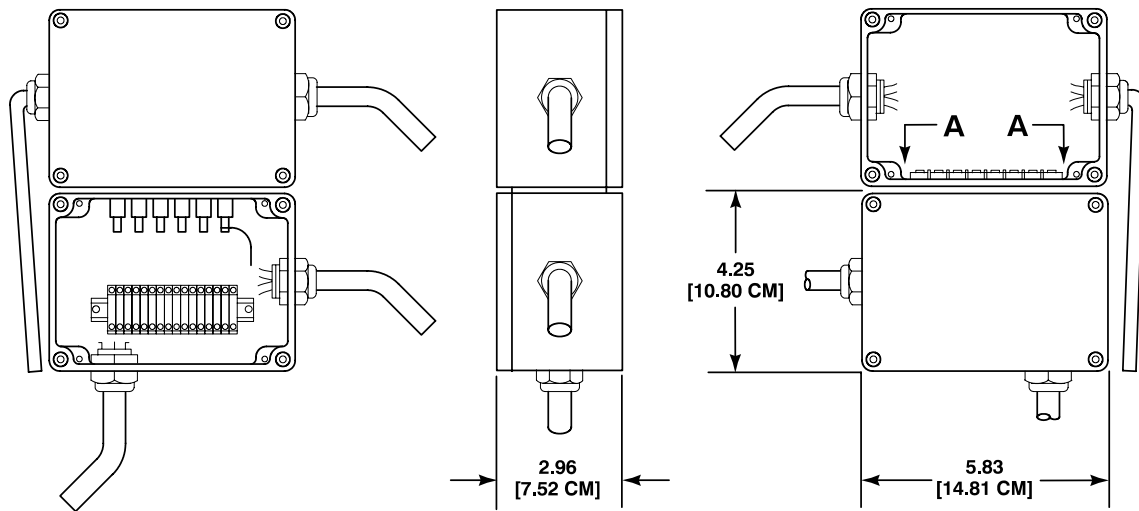

Figure 1. JUNCTION BOX ASSEMBLY - LOCATION.



VIEW A-A

Figure 2. JUNCTION BOX ASSEMBLY - INTERIOR.

INSPECTION

1. Check that the junction box (5) and covers are not bent, cracked, or punctured. Replace if damaged. See Figure 1.
2. Check that the EMI and other gaskets are not cracked, loose, or missing. Repair if damaged.
3. Check that cable and harness connections are tight.
4. Check for accumulated dirt and mildew. Clean if necessary.

REMOVAL

1. Disconnect P3 located behind evaporator access cover and pull through to condenser assembly. (See WP 0019 00, EVAPORATOR COVERS)
2. Remove screws (3). Lockwashers (2), and flat washers (3), securing mounting bracket (4) across junction boxes. See Figure 1.
3. Remove mounting bracket (4).
4. Remove screws securing terminal cover plate located on the compressor assembly.
5. Refer to wiring diagram (WP 0045 00). Remove and tag wires from T1, T2, T3 and ground on the compressor terminals.
6. Loosen strain reliefs so that wiring can be removed from junction boxes once disconnected.
7. With remaining cables attached, carefully remove the junction boxes from the condenser assembly.
8. Remove and tag wires from FL3 through FL10 from terminals located in the junction box assembly. Remove wiring through the strain relief.
9. Remove and tag wires from TB1- 1 through 17 and ground from terminals located in the junction box assembly. Remove wiring through the strain relief.
10. Repair or replace junction box assembly.

INSTALLATION

1. Insert wiring harnesses into the junction box assembly mounting holes. Secure strain reliefs.
2. Refer to wiring diagram (WP 0045 00) and tags applied during removal. Attach wiring to the terminals. Remove all tags.
3. Secure junction box cover(s) with screws.
4. Carefully install junction boxes into the condenser assembly. Install the mounting bracket to secure boxes in place.
5. Route cable harnesses.
6. Refer to wiring diagram (WP 0045 00). Install wires to T1, T2, T3 and ground on the compressor terminals. Remove tags.
7. Use screws to secure terminal cover plate located on the compressor assembly.
8. Reconnect evaporator and condenser assemblies. (See WP 0012 00, EVAPORATOR/CONDENSERASSEMBLY - SEPARATION AND RECONNECTION)

END OF WORK PACKAGE

FIELD LEVEL

24,000 BTUH, SPLIT PACK ENVIRONMENTAL CONTROL UNIT (ECU)

NSN 4120-01-516-4715

F24H4-2

CONDENSER COVERS

0025 00

INITIAL SETUP:

Condenser Top Cover 178K0226-1
Condenser Back Cover 178K0227-1

Personnel Required

Filed level technician (2)

Equipment Condition

ECU removed from shelter (See WP 0005 00,
INSTALLATION SITE PREPARATION)
Power removed from ECU.

Tools And Special Tools

Tool Kit, Refrigeration Ordnance
5180-00-596-1474

Reference

TM9 4120-429-24P

Materials/Parts

Adhesive, Sealant MIL-A-46106 Type I
Coil Guard Assembly 178K0365-1
Dry Cleaning Solvent P-D-680 Type III
Side Screens 178K0401-1

INSPECTION

1. Check that covers are not bent, cracked, or punctured. Replace if damaged. See Figure 1
2. Check that EMI and other gaskets are not cracked, loose, or missing. Replace if damaged.
3. Check that identification, danger, and diagram plates are readable and in place. Replace if damaged (See WP 0002 00, DECALS AND IDENTIFICATION PLATES).
4. Check that lifting rings are securely attached and in good condition. Replace if damaged.
5. Check that screen frame is not bent, dented, or mashed. Replace if damaged.

REMOVAL

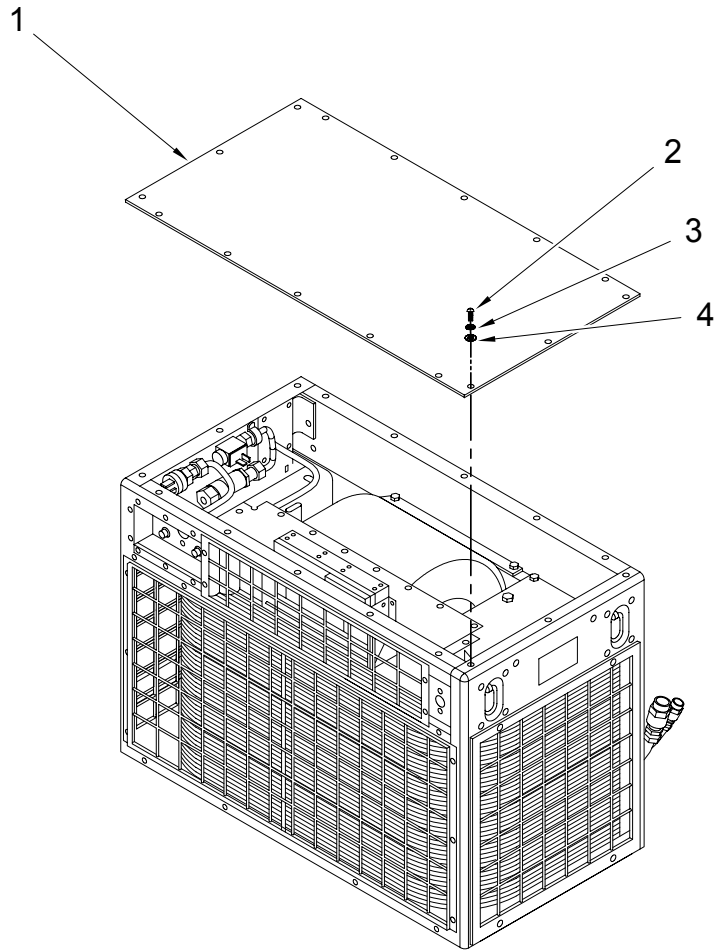

Figure 1. CONDENSER TOP COVER.

WARNING



Disconnect input power to the Environmental Control Unit before performing any maintenance to the electrical system. Voltages used can be lethal. The Evaporator circuit breaker does not disconnect power to the various components of the Environmental Control Unit.

1. Remove screws (2), lockwashers (3), and flat washers (4) securing top condenser cover (1).
See Figure 1
2. Carefully remove the top condenser cover.
3. Remove screws (3), Lockwashers (4), and flat washers (5). Remove back cover (2) and gasket (1).
See Figure 2.
4. Carefully remove the back condenser cover. See Figure 2.
5. Remove screws from condenser front and side screens. See Figure 3.
6. Remove screens.

REPAIR OR REPLACEMENT

NOTE

Prior to removal of old gasket material or insulation, cut the new replacement material to size using the old item as a sample.

1. Remove as much old gasket material as possible by pulling or scraping it away from the metal surface.

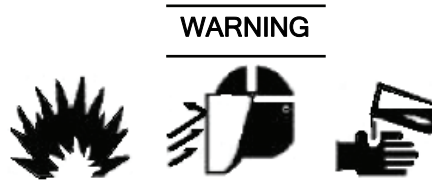

Dry Cleaning Solvent is flammable, and its vapors can be explosive. Repeated or prolonged skin contact or inhalation of vapors can be toxic. Use a well-ventilated area, and keep away from sparks or flame. Use goggles, gloves, and apron when appropriate.

2. Soften and remove old adhesive and gasket residue, using dry cleaning solvent and a stiff brush
3. To replace identification, danger, and diagram plates and lifting rings, use a drill bit slightly smaller than the diameter of the rivet being removed.
4. Drill the rivets out and remove the old part (See WP 0002 00, DECALS AND IDENTIFICATION PLATES).
5. Align holes in replacement part and cover and install new rivets (See WP 0002 00, DECALS AND IDENTIFICATION PLATES).

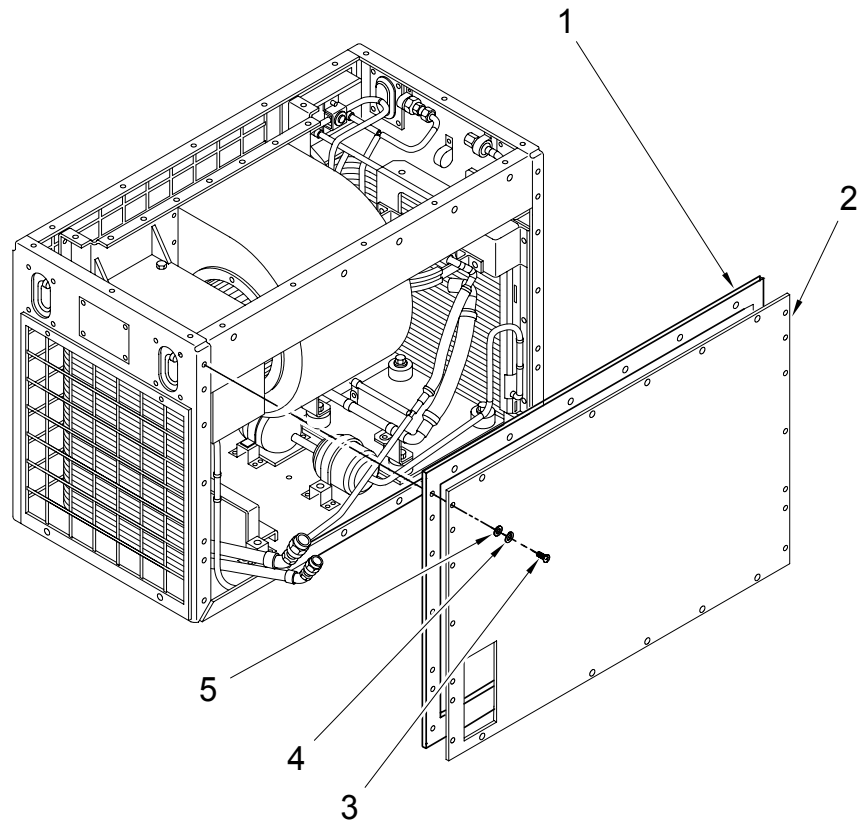

Figure 2. CONDENSER REAR COVER.

6. Minor dents and bent edges can be straightened using common sheet metal repair procedures. Panels that are badly dented, bent, or punctured should be replaced.
7. Should touch up or refinishing be necessary, see WP 0044 00, FINISH REPAINTING AND REFINISHING GENERAL .
8. EMI gasket material and regular gaskets specified for this unit are supplied with adhesive backing.
9. Cut gasket (1) to size. Be sure that EMI gasket corners are mitered so that good continuous edge contact is made. Figure 2
10. Be sure that surface to which gasket is to be applied is clean and free of paint and old adhesive material.
11. Remove backing material from adhesive side and immediately press gasket in place. Be sure that good edge-to-edge contact is made on the EMI gaskets.

INSTALLATION

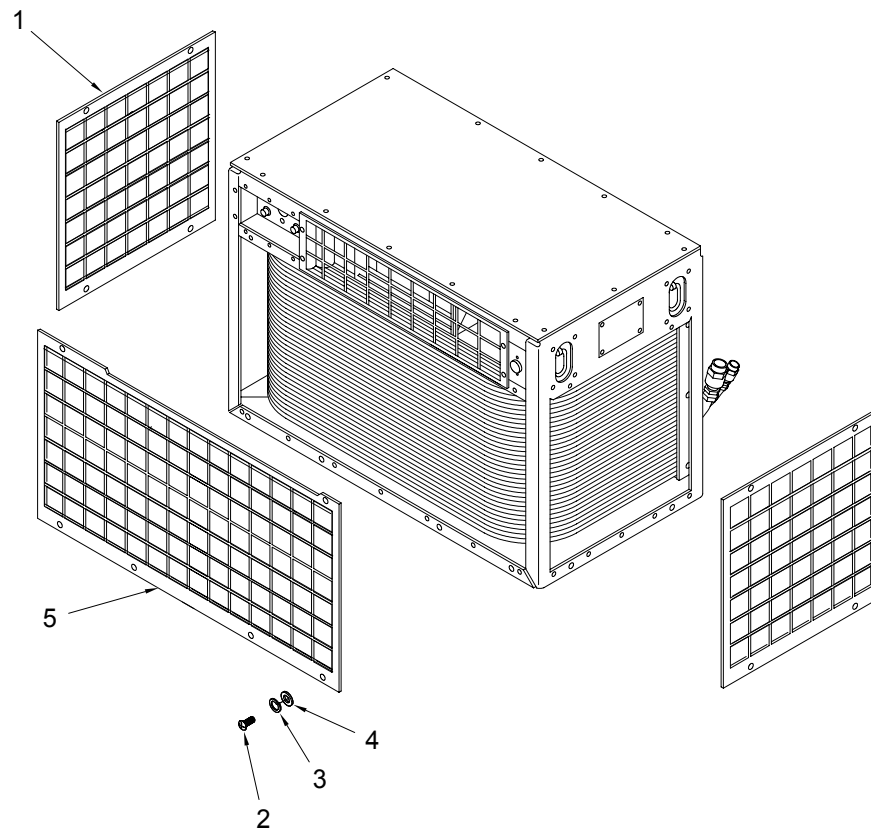

Figure 3. SCREEN COVERS.

1. Line up screw holes in covers and ECU housing.
2. Install top and back condenser covers.
3. Install side screens (1), and front screen (5) using screws (2), lockwashers (3), and flat washers (4).
Figure 3

END OF WORK PACKAGE

FIELD LEVEL

24,000 BTUH, SPLIT PACK ENVIRONMENTAL CONTROL UNIT (ECU)

NSN 4120-01-516-4715

F24H4-2

CONDENSER COIL ASSEMBLY

0026 00

INITIAL SETUP:

Personnel Required

Field level technician (2)

Tools And Special Tools

Tool Kit, Refrigeration Ordnance

5180-00-596-1474

Brazing Torch (1)

Materials/Parts

Nitrogen 6830-00-292-0732 (1)

Condenser Coil Assembly 178K0228 (1)

Equipment Condition

ECU removed from shelter (See WP 0005 00, INSTALLATION SITE PREPARATION)

Covers and Grille removed (See WP 0025 00, CONDENSER COVERS)

Blower and motor assembly removed (See WP 0027 00, CONDENSER BLOWER AND MOTOR ASSEMBLY)

Reference

TM 9-4120-429-24P

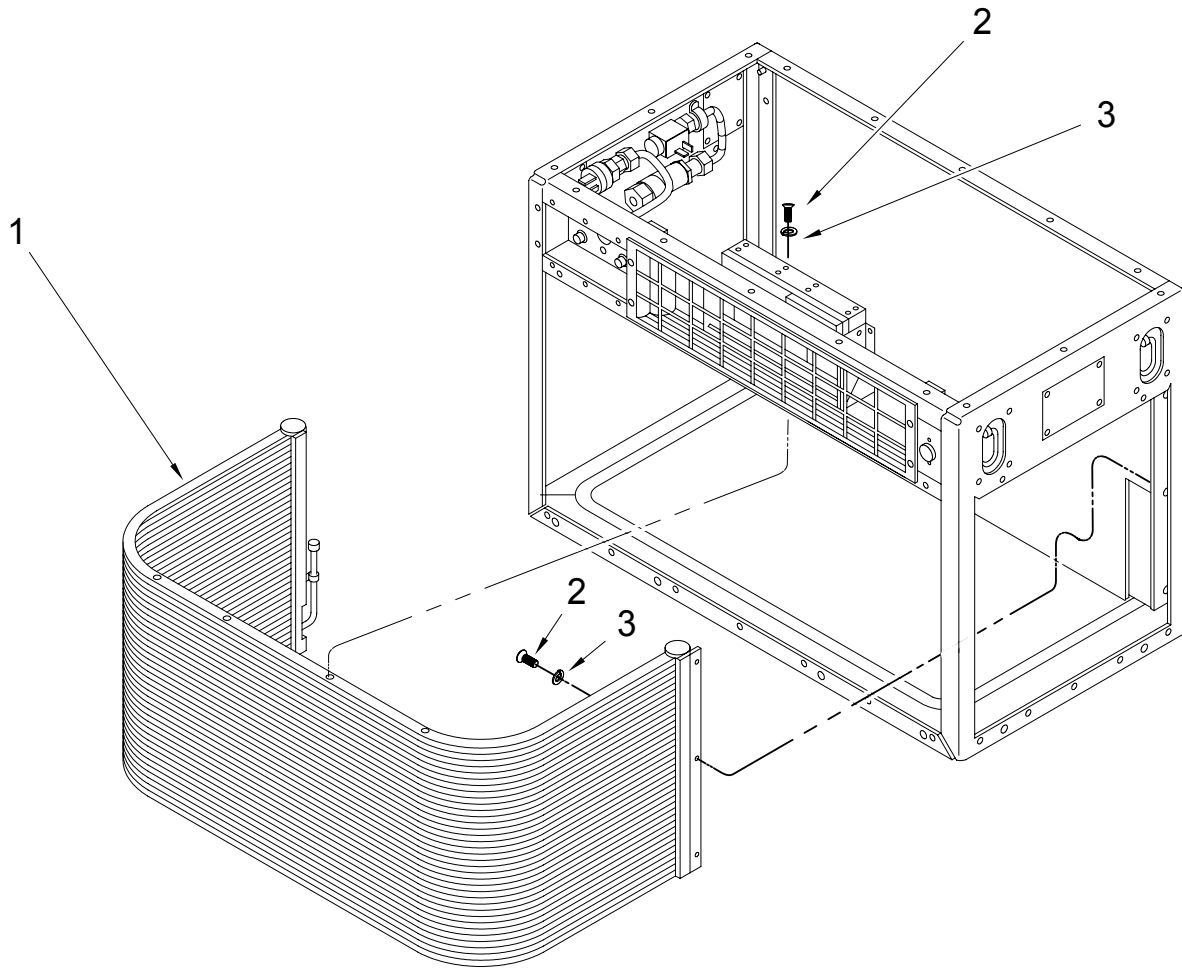

Figure 1. CONDENSER COIL ASSEMBLY.

INSPECTION

WARNING



When handling coils, wear gloves to avoid cuts and reduce fin damage on the coil.

WARNING

Compressed air used for cleaning purposes will not exceed 30 psi (2.1 kg/square centimeter). Do not direct compressed air against the skin. Use goggles or full-face shield.

CAUTION

Do not use steam to clean coil. Apply heat to copper tubing only. Do not apply heat to coil connections.

1. Check for accumulated dirt. Clean if an accumulation of dirt is evident.
2. Check fins for dents, bent edges or any condition that would block or distort airflow. Straighten all damaged fins with a plastic fin comb.
3. Discharge the Refrigerant R-410A system per WP 0041 00, EVACUATING THE REFRIGERANT R-410A SYSTEM.

NOTE

Wrap wet rags near joints being brazed. Use tape to cover open joints.

4. While purging the system with nitrogen, apply heat and separate the remaining tubing from the coil and area of the coil. (See WP 0030 00, FILTER-DRYER REFRIGERANT and WP 0043 00, BRAZING/DEBRAZING PROCEDURES).
5. Remove the screws that attach the coil to the sides and top of housing. Cut wires to TS2.
6. Carefully rotate coil and remove by sliding from front of housing.

CLEANING

1. Clean coil with a soft bristled brush, vacuum cleaner and brush attachment, or use compressed air at 30 psi or less from the inside of the coil to blow the dirt out. Take care to avoid fin damage. When using compressed air, wear safety glasses or goggles. Dirt can be blown into your eyes.

REPAIR OR REPLACEMENT

1. Repairs are limited to replacement of plate nut(s), rivets, and the straightening of mashed fins.
2. Plate nuts may be removed by drilling out the old rivets using a drill bit slightly smaller than the diameter of the rivet.
3. Install new plate nut(s) and rivets.

4. If fins are mashed or dented so that the airflow across the coil would be blocked, straighten them using a plastic fin comb.

INSTALLATION

WARNING



When handling coils, wear gloves to avoid cuts and reduce fin damage on the coil.

1. Carefully slide coil (1) and place into position in housing, through housing front. See Figure 1.
2. Secure coil (1) to housing with screws (2) and lockwashers (3). See Figure 1.
3. While purging the system with nitrogen, braze the tubing joints. (See WP 0040 00, LEAK TESTING THE REFRIGERANT R-410A SYSTEM and WP 0043 00, BRAZING/DEBRAZING PROCEDURES).
4. Replace the filter-dryer. (See WP 0030 00, FILTER-DRYER REFRIGERANT).
5. Check to be sure all tubing has been reconnected.
6. Evacuate and charge the Refrigerant R-410A system. (See WP 0041 00, EVACUATING THE REFRIGERANT R-410A SYSTEM and WP 0042 00, CHARGING THE REFRIGERANT R-410A SYSTEM).
7. Leak test all newly connected joints and those in the repair area. (See WP 0040 00, LEAK TESTING THE REFRIGERANT R-410A SYSTEM).
8. Install condenser covers and grille. (See WP 0025 00, CONDENSER COVERS).

END OF WORK PACKAGE

FIELD LEVEL

24,000 BTUH, SPLIT PACK ENVIRONMENTAL CONTROL UNIT (ECU)

NSN 4120-01-516-4715

F24H4-2

CONDENSER BLOWER AND MOTOR ASSEMBLY

0027 00

INITIAL SETUP:

Personnel Required

Field level technician (2)

Materials/Parts

Inlet Ring 618 - 762

Discharge Assembly 178K0247-1

Impeller R762-362D-CCW X 3/4 BORE

Motor, AC 02-014722

Equipment Condition

ECU removed from shelter (See WP 0005 00,

INSTALLATION SITE PREPARATION)

Top and rear covers removed (WP 0025 00, CONDENSER COVERS)

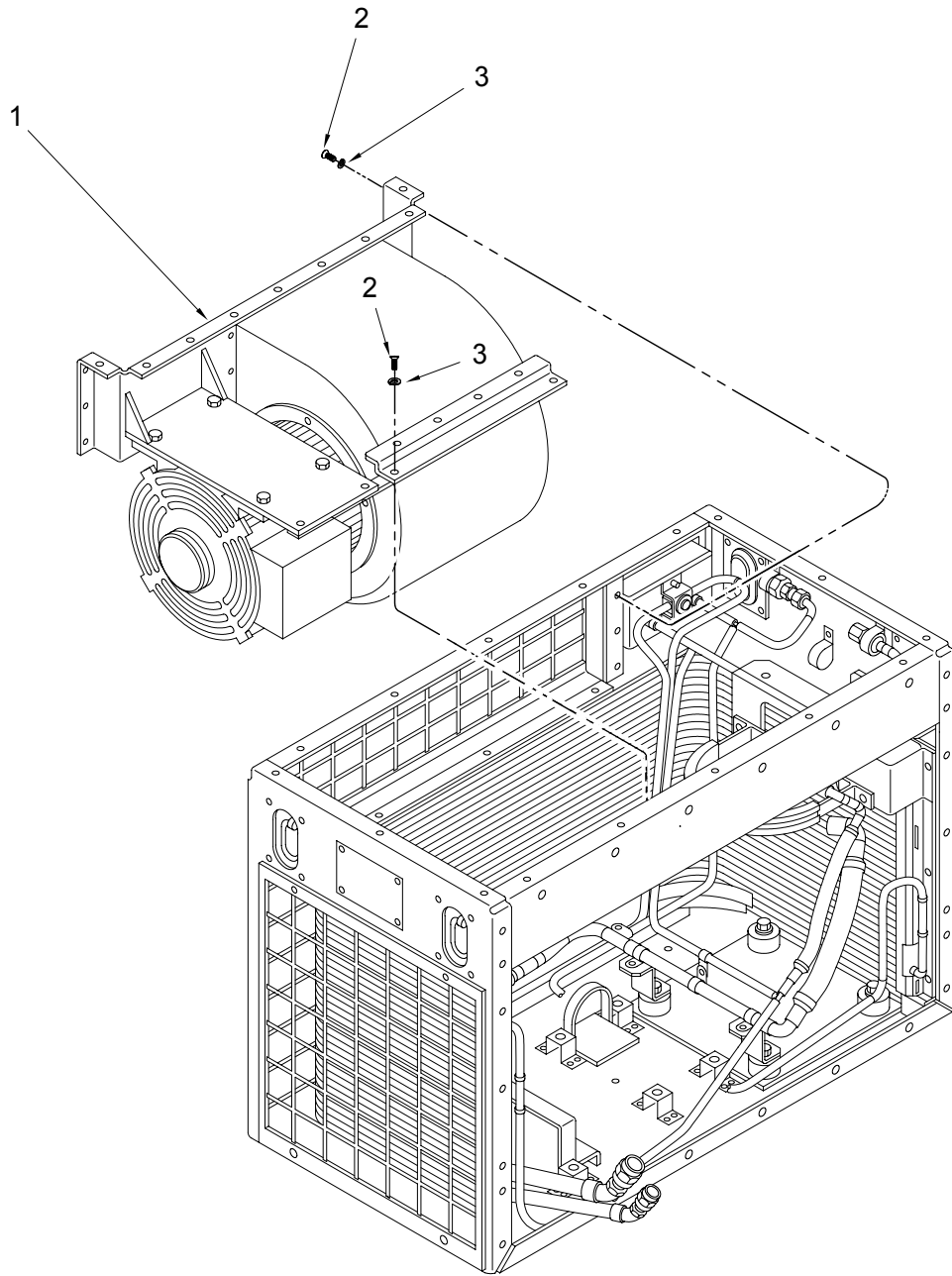

Figure 1. CONDENSER BLOWER AND MOTOR ASSEMBLY - LOCATION.

INSPECTION

1. Check that blower housing and fan inlet is not damaged. Replace them if they are bent, badly dented, or cracked.
2. Check that plate nuts in blower housing are in place and secure. Replace them if they are loose or damaged.
3. Check that impeller is in good condition. Replace it if it is out of round, dented, broken, or if the hub is loose.
4. Check to see that the setscrew is not missing.
5. Check motor to see that it rotates freely without excessive lateral end play.
6. Check motor for evidence of overheating.
7. Check connector J4 for loose, damaged, or missing pins.

REMOVAL

1. Remove screws (2) and lockwashers (3) that secure blower housing to front and rear condenser housing. Carefully remove blower and motor assembly (1) through top of condenser housing. See Figure 1.
2. Disconnect J4 connector from motor connector P4.
3. Remove blower and motor assembly and place on flat surface.
4. Remove screws from inlet ring (1) on blower housing. See Figure 2.
5. Loosen setscrews on impeller (2) shaft collar. See Figure 2.
6. Slide impeller from motor shaft.
7. Remove bolts, nuts and washer securing motor to mounting plate (4). See Figure 2.
8. Remove motor.

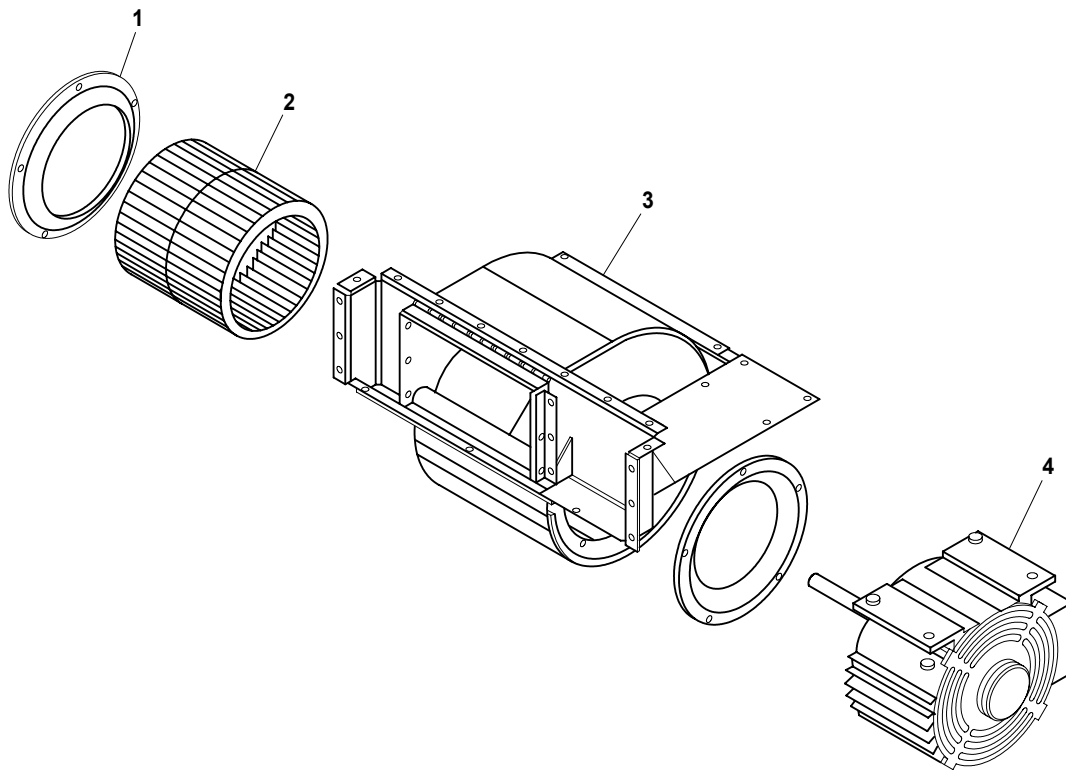

Figure 2. CONDENSER BLOWER AND MOTOR ASSEMBLY.

CLEANING

1. Using clean dry cloth and soft brush remove dirt from impeller, blower housing, cover plate, extension shaft, and outside of motor.

REPAIR OR REPLACEMENT

1. Housing repairs are limited to replacement of rivets and plate nuts.
2. Plate nuts may be removed by drilling out the old rivets using a drill bit slightly smaller than the diameter of the rivet.
3. Install new plate nut(s) and rivets.
4. Repair of the condenser fan motor is limited to replacement of the electrical connector. For further information on electric motor repair, refer to FM 20-31 (Electric Motor and Generator Repair).
5. To replace the connector, remove the screws from the terminal box cover.
6. Remove the cover.
7. Remove the screws from the connector (P4).
8. Tag and unsolder leads.
9. Remove the old connector.

10. See wiring diagram and tags and solder leads to the new connector. Remove the tags.
11. Install the connector with screws.

INSTALLATION

1. Slip the motor into place and position impeller loosely on motor shaft.
2. Line up motor and bracket bolt holes.
3. Fasten motor to bracket with bolts, lockwashers, and flat washers.
4. Align impeller setscrews with flat surface on motor shaft.
5. Position impeller on shaft for equal clearance from blower housing side walls.
6. Tighten impeller setscrews to secure impeller on motor shaft.
7. Spin impeller and check that it clears inlet all around.
8. If impeller does not spin freely, readjust clearance.
9. Connect P4 connector plug to J4 motor connector.

CAUTION

Sheet metal screws are used to mount fan inlet ring. Take care that mounting screw holes are not stripped.

10. Place blower in condenser housing and align holes.
11. Secure motor side of blower housing.
12. Insert shims between blower housing bracket and rear condenser housing angle.
13. Secure blower and motor housing bracket with screws, flat washers, and locknuts.
14. Install rear condenser cover. See WP 0025 00, CONDENSER COVERS .
15. Install top condenser cover. See WP 0025 00, CONDENSER COVERS .

TESTING

1. To test motor, disconnect P4 from J4.
2. Using multimeter, measure low speed 3 phase windings at P4: A to B, B to C, and A to C. All resistance should be above zero, but less than 2 ohms.
3. Using multimeter, measure high speed 3 phase windings at P4: D to E, E to F, and D to F. All resistances should be above zero, but less than 2 ohms.
4. Using multimeter, measure resistance between pins G and H. Resistance should be zero meaning the low and high speed thermostats are closed.
5. Motor with shorted, open or grounded windings or open thermostatic switch should be replaced.

END OF WORK PACKAGE

FIELD LEVEL

24,000 BTUH, SPLIT PACK ENVIRONMENTAL CONTROL UNIT (ECU)

NSN 4120-01-516-4715

F24H4-2

CONDENSER HOUSING

0028 00

INITIAL SETUP:

Personnel Required

Field level technician (2)

Equipment Condition

ECU removed from shelter (See WP 0005 00,
INSTALLATION SITE PREPARATION)

Tools And Special Tools

Tool Kit, Refrigeration Ordnance
5180-00-596-1474

Reference

TM 9-4120-429-24P

Materials/Parts

Condenser Housing 178K0238 (1)
Dry Cleaning Solvent P-D-680 Type III (1)
Adhesive, Sealant MIL-A-46106 Type I (1)

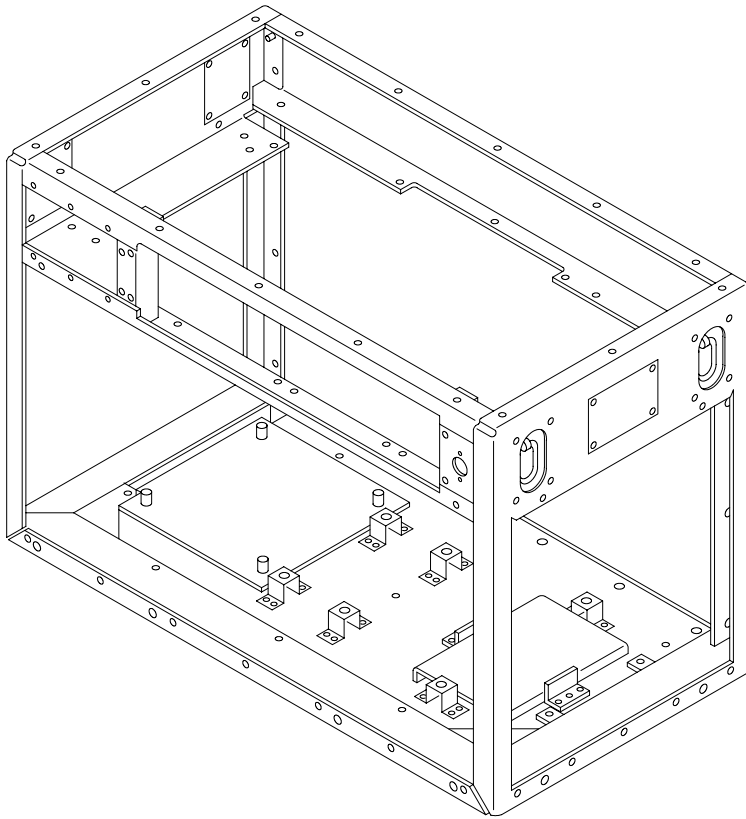

Figure 1. CONDENSER HOUSING.

INSPECTION

1. Check for broken welds, badly bent or dented parts, and cracked or broken parts.
2. Check that plate nuts and blind nuts are in place and secure.

REPAIR OR REPLACEMENT

NOTE

Prior to removal of old gasket material or insulation, cut the new replacement material to size using the old item as a sample.

1. Remove as much old insulation material as possible, by scraping it away from the metal surface.

WARNING

Dry Cleaning Solvent is flammable, and its vapors can be explosive. Repeated or prolonged skin contact or inhalation of vapors can be toxic. Use a well-ventilated area, and keep away from sparks or flame. Use goggles, gloves, and apron when appropriate.

2. Soften and remove old adhesive and residue, using dry cleaning solvent and a stiff brush.

NOTE

Insulation at top of coil should be attached in proper position to top metal cover of condenser coil. Insulation at bottom should be attached to condenser housing angle face below coil.

3. Be sure that the surface to which the insulation is to be applied is clean and free of paint and old adhesive material.
4. Coat the mating surfaces of the metal and the insulation with adhesive. Let both surfaces air dry until the adhesive is tacky, but will not stick to the fingers.
5. Starting with an end, carefully attach the insulation to the metal. Press into firm contact all over.
6. Minor dents and bent edges can be straightened using common sheet metal repair procedures.
7. Should touch up or refinishing be necessary, (See WP 0043 00, BRAZING/DEBRAZING PROCEDURES).
8. Install left end condenser cover. (See WP 0025 00, CONDENSER COVERS).
9. Install top condenser cover. (See WP 0025 00, BRAZING/DEBRAZING PROCEDURES).
10. Install the ECU on shelter. (See WP 0005 00, INSTALLATION SITE PREPARATION).
11. Connect power.

END OF WORK PACKAGE

FIELD LEVEL

24,000 BTUH, SPLIT PACK ENVIRONMENTAL CONTROL UNIT (ECU)

NSN 4120-01-516-4715

F24H4-2

RECEIVER ASSEMBLY

0029 00

INITIAL SETUP:

Personnel Required

Field level technician (2)

Tools And Special Tools

Tool Kit, Refrigeration Ordnance
5180-00-596-1474

Materials/Parts

Nitrogen 6830-00-292-0732
Filter-dryer Refrigerant 500T2415
Receiver 1321E6163

Equipment Condition

ECU removed from shelter (See WP 0005 00, INSTALLATION SITE PREPARATION)
Evaporator and condenser section assemblies separated (See WP 0012 00, EVAPORATOR/ CONDENSER ASSEMBLY - SEPARATION AND RECONNECTION)
Top cover removed (See WP 0025 00, CONDENSER COVERS)
Rear cover removed (See WP 0025 00, CONDENSER COVERS)
Blower and motor assembly removed (See WP 0027 00, CONDENSER BLOWER AND MOTOR ASSEMBLY)

References

TM 9-4120-429-24P

INSPECTION

1. Check for general condition and signs of leakage. If leakage is suspected, leak test per WP 0040 00, LEAK TESTING THE REFRIGERANT R-410A SYSTEM .
2. Check that mounting clamps are secure.

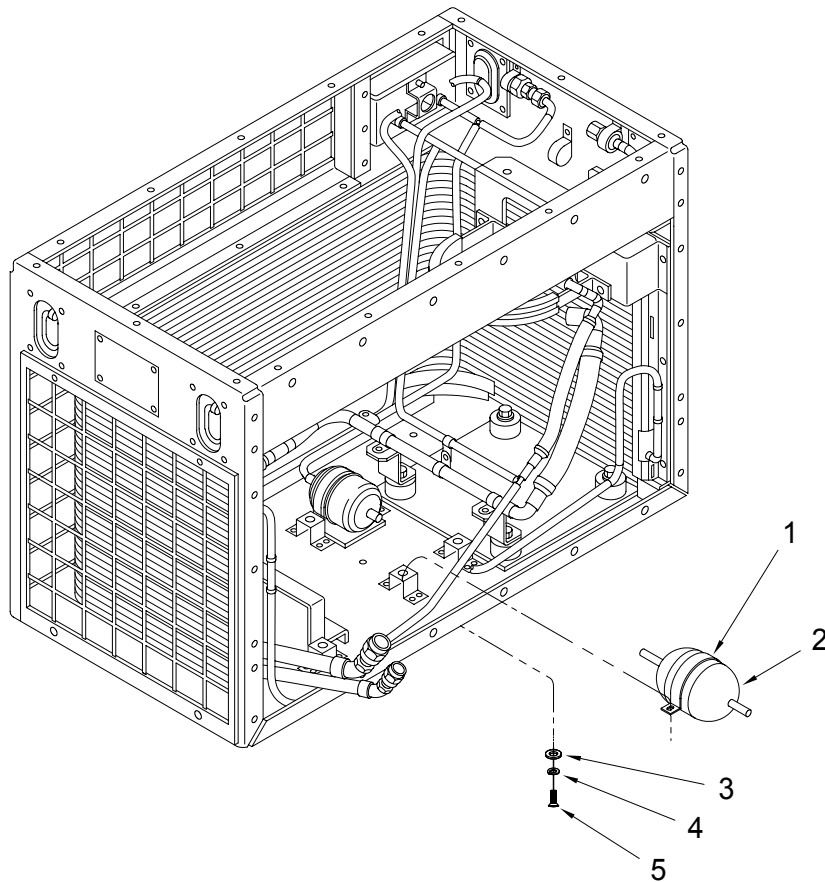

Figure 1. RECEIVER ASSEMBLY.

REMOVAL

1. Discharge the Refrigerant R-410A system. (See WP 0041 00, EVACUATING THE REFRIGERANT R-410A SYSTEM .
2. While purging the system with nitrogen, apply heat and separate the tubing.
3. Remove screws (5), lockwashers and flat washers (3) from bottom of condenser securing clamp (1) and receiver (2) to housing. See Figure 1.
4. Remove receiver (2) from condenser housing. See Figure 1.

INSTALLATION

1. Position receiver (2) in condenser housing. See Figure 1.
2. Align tubing connections.

3. Install clamp (1) to secure receiver to bottom condenser housing channel.
4. While purging the system with nitrogen, braze the tubing joints. (See WP 0040 00, LEAK TESTING THE REFRIGERANT R-410A SYSTEM and WP 0043 00, BRAZING/DEBRAZING PROCEDURES).
5. Leak test all newly connected joints and those in the repair area. (See WP 0040 00, LEAK TESTING THE REFRIGERANT R-410A SYSTEM).
6. Install rear condenser cover. (See WP 0025 00, CONDENSER COVERS).
7. Connect evaporator and condenser section assemblies. (See WP 0012 00, EVAPORATOR/CONDENSER ASSEMBLY - SEPARATION AND RECONNECTION).
8. Evacuate and charge the Refrigerant R-410A system. (See WP 0041 00, EVACUATING THE REFRIGERANT R-410A SYSTEM and WP 0042 00, CHARGING THE REFRIGERANT R-410A SYSTEM).
9. Install environmental control unit on shelter. (See WP 0005 00, INSTALLATION SITE PREPARATION).

END OF WORK PACKAGE

FIELD LEVEL

24,000 BTUH, SPLIT PACK ENVIRONMENTAL CONTROL UNIT (ECU)

NSN 4120-01-516-4715

F24H4-2

FILTER-DRYER REFRIGERANT

0030 00

INITIAL SETUP:

ECU removed from shelter (See WP 0005 00, INSTALLATION SITE PREPARATION)

Personnel Required

Power disconnected.

Direct Support Level Technician (1)

Rear cover removed (See WP 0025 00, CONDENSER COVERS)

Tools And Special Tools

Top cover removed (See WP 0025 00, CONDENSER COVERS)

Tool Kit, Refrigeration Ordnance
5180-00-596-1474

Blower and motor assembly removed (See WP 0027 00, CONDENSER BLOWER AND MOTOR ASSEMBLY)

Materials/Parts

Filter-dryer Refrigerant 500T2415 (1)

Reference

Equipment Condition

TM9 4120-429-24P

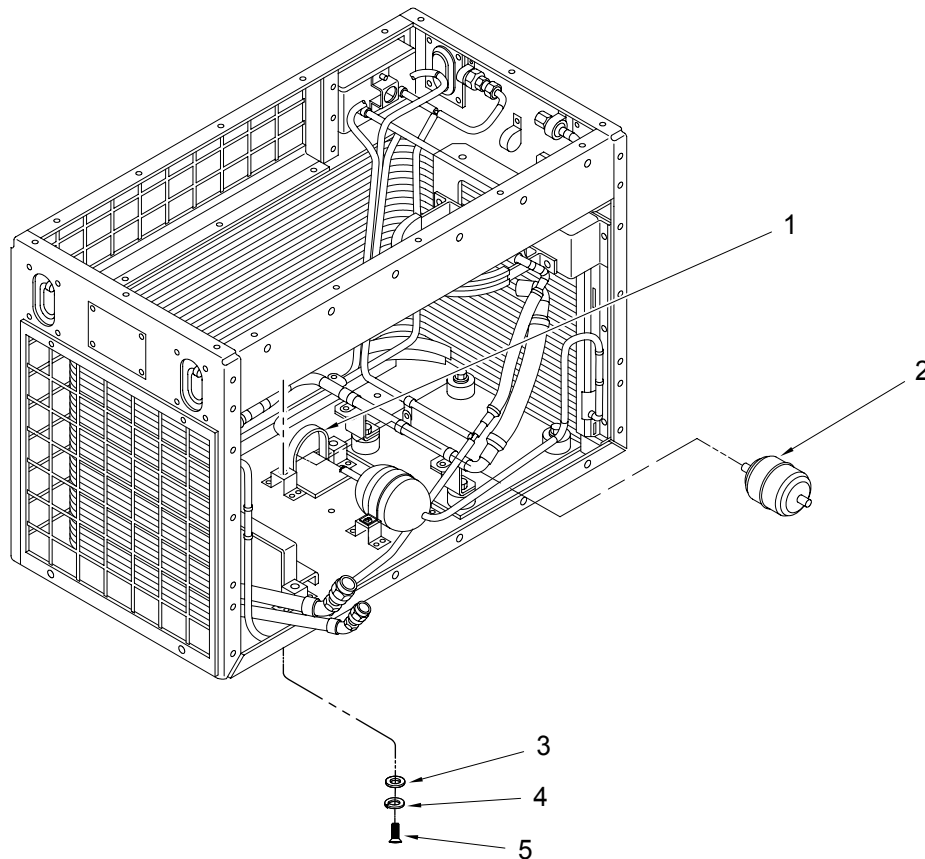

Figure 1. FILTER-DRYER REFRIGERANT.

INSPECTION

1. Check for general condition and signs of leakage. If leakage is suspected, leak test per WP 0040 00, LEAK TESTING THE REFRIGERANT R-410A SYSTEM .
2. Check that clamps are in place and secure. Tighten clamps if they are loose. Replace if missing.

REMOVAL

1. Discharge the Refrigerant R-410A system per WP 0041 00, EVACUATING THE REFRIGERANT R-410A SYSTEM .
2. Loosen screws (5), lockwashers (4) and flat washers (3) through bottom of condenser assembly securing filter-dryer bracket (1). See Figure 1.
3. Remove bracket (1) if necessary.
4. Debraze copper tubing connecting filter-dryer. (See WP 0043 00, BRAZING/DEBRAZING PROCEDURES)
5. Slide filter-dryer (2) from bracket. Remove filter dryer. Note direction of flow arrow for installation. See Figure 1

INSTALLATION**CAUTION**

Replacement dehydrators are packaged with sealing caps on the flare fittings, to prevent moisture contamination of the desiccant filtering media. Remove these caps immediately prior to installation. Never install a dehydrator from which caps have been removed for an extended or unknown period of time.

1. Place filter-dryer (2) in unit and slip into bracket (1) on bottom of housing. Be sure flow arrow is pointing in the proper direction.
2. Adjust screws (5) to tighten clamp.
3. Braze tubing to connect filter-dryer.
4. Leak test all newly connected joints and those in the repair area. (See WP 0040 00, LEAK TESTING THE REFRIGERANT R-410A SYSTEM).
5. Evacuate and recharge the Refrigerant R-410A system. (See WP 0041 00, EVACUATING THE REFRIGERANT R-410A SYSTEM and WP 0042 00, CHARGING THE REFRIGERANT R-410A SYSTEM).
6. Install blower and motor assembly. (See WP 0027 00, CONDENSER BLOWER AND MOTOR ASSEMBLY)
7. Install rear and top condenser covers. (See WP 0025 00, CONDENSER COVERS)

END OF WORK PACKAGE

FIELD LEVEL

24,000 BTUH, SPLIT PACK ENVIRONMENTAL CONTROL UNIT (ECU)

NSN 4120-01-516-4715

F24H4-2

SIGHT GLASS

0031 00

INITIAL SETUP:

Personnel Required

Field level technician (2)

Tools And Special Tools

Tool Kit, Refrigeration Ordnance
5180-00-596-1474

Materials/Parts

Nitrogen 6830-00-292-0732 (1)
Sight Glass 500T2419-1 (1)
Filter-dryer Refrigerant 500T2415 (1)

Equipment Condition

ECU removed from shelter (See WP 0005 00,
INSTALLATION SITE PREPARATION)
Top cover removed (See WP 0025 00,
CONDENSER COVERS)
Blower and motor assembly removed (See WP
0027 00, CONDENSER BLOWER AND MOTOR
ASSEMBLY)
Power disconnected

Reference

TM 9-4120-429-24P

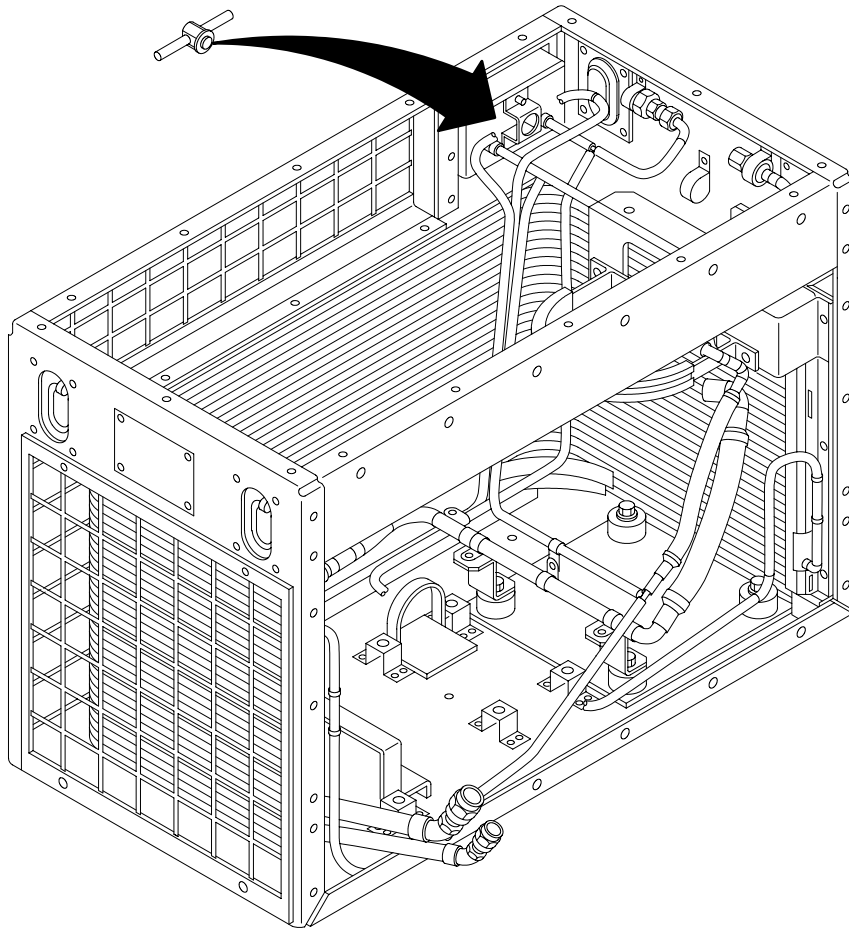

Figure 1. SIGHT GLASS.

INSPECTION

1. Check that glass window is clean and not cracked or broken. Clean if dirty. Replace sight glass if cracked or broken.
2. Check for evidence of leakage. Leak test if leak is suspected. Repair or replace as indicated.

REMOVAL

1. Discharge the Refrigerant R-410A system per WP 0041 00, EVACUATING THE REFRIGERANT R-410A SYSTEM .
2. While purging the system with nitrogen, apply heat and separate the tubing. (See WP 0040 00, LEAK TESTING THE REFRIGERANT R-410A SYSTEM and WP 0043 00, BRAZING/DEBRAZING PROCEDURES).

3. Remove screws and sight glass bracket.
4. Remove the sight glass.

INSTALLATION

1. Position sight glass in unit.
2. Secure sight glass with bracket and screws. Be sure that sight glass is centered on opening in housing.
3. While purging the system with nitrogen, braze the tubing joints. See WP 0040 00, LEAK TESTING THE REFRIGERANT R-410A SYSTEM and WP 0043 00, BRAZING/DEBRAZING PROCEDURES .
4. Replace the filter-dryer. (See WP 0030 00, FILTER-DRYER REFRIGERANT).
5. Leak test all newly connected joints and those in the repair area. (See WP 0040 00, LEAK TESTING THE REFRIGERANT R-410A SYSTEM).
6. Evacuate and recharge the Refrigerant R-410A system. (See WP 0041 00, EVACUATING THE REFRIGERANT R-410A SYSTEM and WP 0042 00, CHARGING THE REFRIGERANT R-410A SYSTEM).
7. Install blower and motor assembly. (See WP 0027 00, CONDENSER BLOWER AND MOTOR ASSEMBLY)
8. Install condenser top cover. (See WP 0025 00, CONDENSER COVERS).

END OF WORK PACKAGE

FIELD LEVEL

24,000 BTUH, SPLIT PACK ENVIRONMENTAL CONTROL UNIT (ECU)

NSN 4120-01-516-4715

F24H4-2

LOW PRESSURE SWITCH

0032 00

INITIAL SETUP:

Filter-dryer Refrigerant CF-20 500T2415 (1)

Personnel Required

Field level technician (2)

Equipment Condition

ECU removed from shelter (See WP 0005 00, INSTALLATION SITE PREPARATION).

Tools And Special Tools

Tool Kit, Refrigeration Ordnance
5180-00-596-1474

Top cover removed (See WP 0025 00, CONDENSER COVERS).

Materials/Parts

Low Pressure Switch 500K2659 (1)

References

TM9-4120-429-24P

REMOVAL

1. Discharge the Refrigerant R-410A system as per WP 0041 00.
2. Remove wiring from low-pressure switch.
3. Remove the low-pressure switch from copper tubing.
4. Remove low-pressure switch.

INSTALLATION

1. Position low-pressure switch in unit.
2. Install switch to copper tubing.
3. Secure low-pressure switch with mounting hardware.
4. Recharge the Refrigerant R-410A system. (See WP 0041 00, EVACUATING THE REFRIGERANT R-410A SYSTEM and WP 0042 00, CHARGING THE REFRIGERANT R-410A SYSTEM).
5. Leak test all newly connected joints and those in the repair area. (See WP 0040 00, LEAK TESTING THE REFRIGERANT R-410A SYSTEM).
6. Install condenser top cover. (See WP 0025 00, CONDENSER COVERS).

TEST

1. Remove wire from terminal 1 or 2 on the low-pressure switch.
2. Measure for continuity between terminals 1 and 2.
3. If open is measured, replace switch.

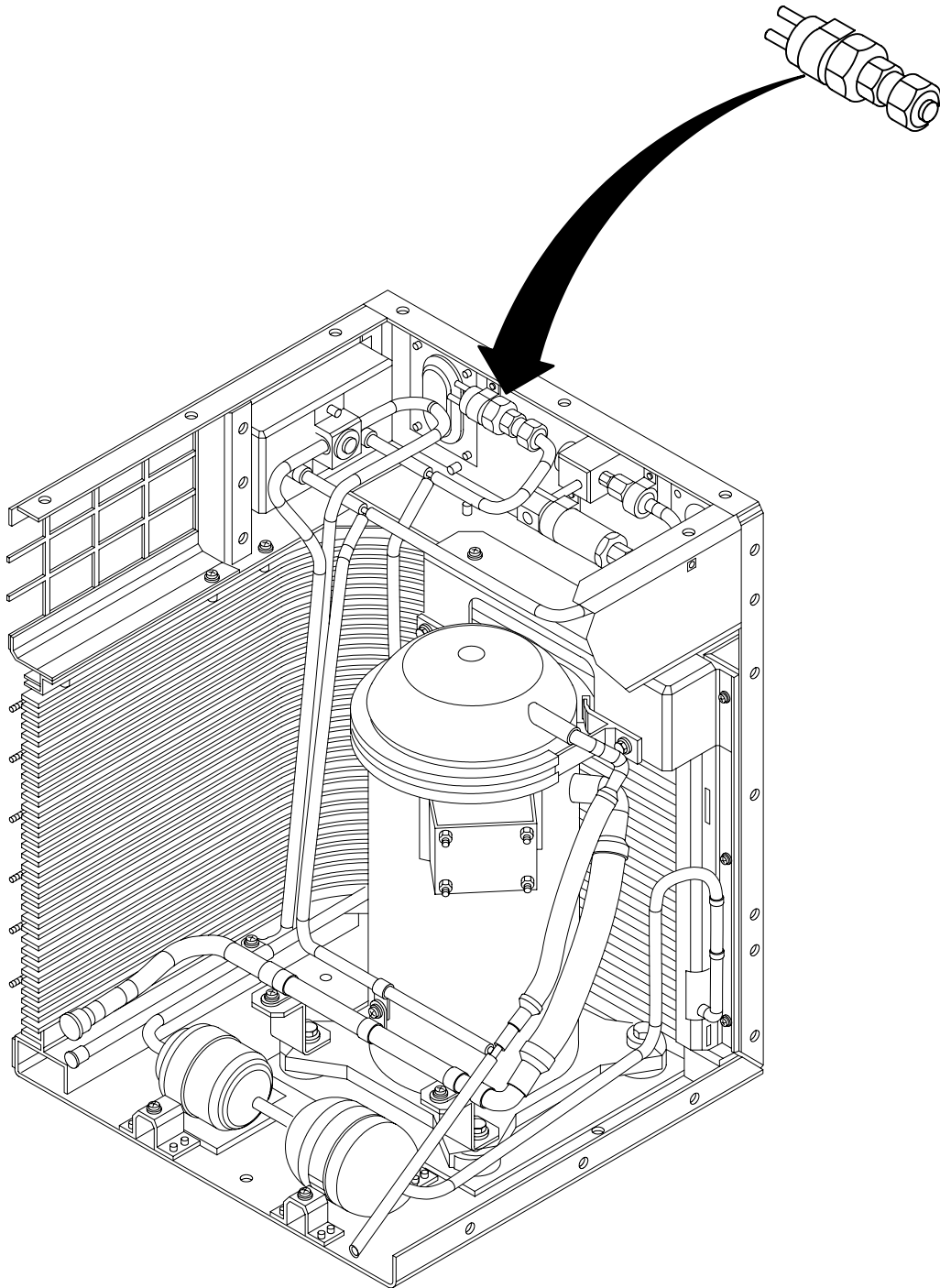

Figure 1. LOW PRESSURE SWITCH AND OVERPRESSURE VALVE.

END OF WORK PACKAGE

FIELD LEVEL

24,000 BTUH, SPLIT PACK ENVIRONMENTAL CONTROL UNIT (ECU)

NSN 4120-01-516-4715

F24H4-2

HIGH PRESSURE SWITCH

0033 00

INITIAL SETUP:	Filter-dryer Refrigerant CF-20 500T2415 (1)
Personnel Required Field level technician (2)	Equipment Condition ECU removed from shelter (See WP 0005 00, INSTALLATION SITE PREPARATION). Top cover removed (See WP 0025 00, CONDENSER COVERS).
Tools And Special Tools Tool Kit, Refrigeration Ordnance 5180-00-596-1474	References Tm 9-4120-429-24P
Materials/Parts High Pressure Switch 500K2660 (1)	

REMOVAL

1. Discharge the Refrigerant R-410A system per WP 0041 00, EVACUATING THE REFRIGERANT R-410A SYSTEM.
2. Remove wiring from high-pressure switch.
3. Remove the high-pressure switch from copper tubing.
4. Remove high-pressure switch.

INSTALLATION

1. Position high-pressure switch in unit.
2. Install switch to copper tubing.
3. Secure high-pressure switch with mounting hardware.
4. Replace the filter-dryer. (See WP 0030 00, FILTER-DRYER REFRIGERANT).
5. Leak test all newly connected joints and those in the repair area. (See WP 0040 00, LEAK TESTING THE REFRIGERANT R-410A SYSTEM).
6. Recharge the Refrigerant R-410A system. (See WP 0041 00, EVACUATING THE REFRIGERANT R-410A SYSTEM and WP 0042 00, CHARGING THE REFRIGERANT R-410A SYSTEM).
7. Install condenser top cover. (See WP 0025 00, CONDENSER COVERS).

TEST

1. Remove wire from terminal 1 or 2 on the low-pressure switch.
2. Measure for continuity between terminals 1 and 2.
3. If open is measured, replace switch.

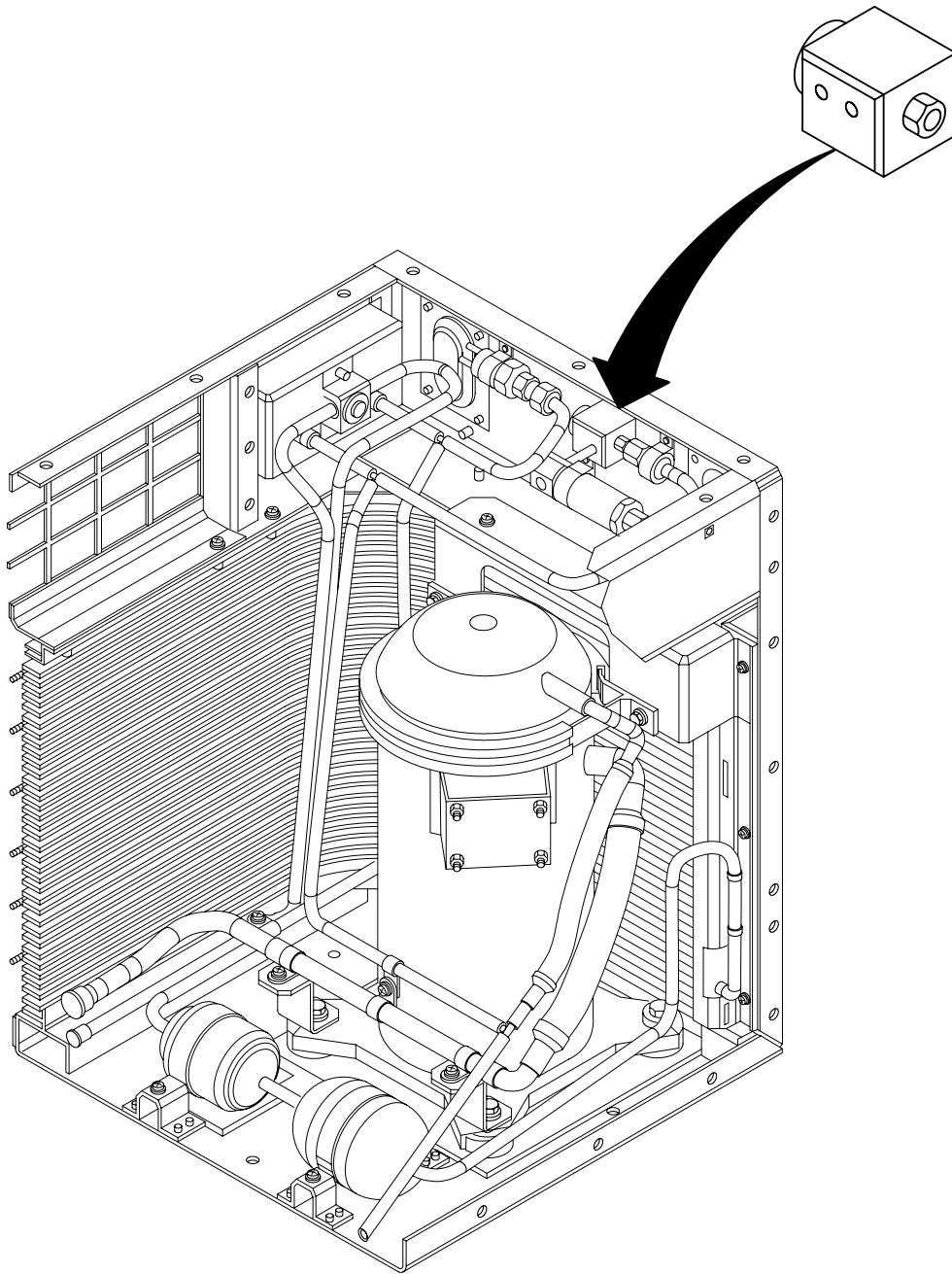

Figure 1. HIGH PRESSURE SWITCH.

END OF WORK PACKAGE

FIELD LEVEL

24,000 BTUH, SPLIT PACK ENVIRONMENTAL CONTROL UNIT (ECU)

NSN 4120-01-516-4715

F24H4-2

COMPRESSOR ASSEMBLY

0034 00

INITIAL SETUP:

ECU removed from shelter (See WP 0005 00, INSTALLATION SITE PREPARATION).

Personnel Required

ECU Separated (See WP 0012 00)

Field level technician (2)

Top and rear cover removed (See WP 0025 00, CONDENSER COVERS).

Tools And Special Tools

Blower assembly removed (See WP 0027 00, CONDENSER BLOWER AND MOTOR ASSEMBLY).

Tool Kit, Refrigeration Ordnance
5180-00-596-1474

Materials/Parts

R-410A evacuated from system (See WP 0040 00, EVACUATING THE REFRIGERANT R-410A SYSTEM)

Compressor Assy 001T0252-1 (1)
Filter-dryer Refrigerant CF-20 500T2415 (1)

References

TM 9-4120-4224P

Equipment Condition

WARNING

Allow compressor to cool before touching. Severe burns can result from touching hot compressor.

CAUTION

Compressor weighs 65 pounds (30 kg). Two-person lift is required.

INSPECTION

1. Ensure power has been disconnected at the power source.

NOTE

The compressor and motor assembly are hermetically sealed in a metal canister and cannot be repaired.

REMOVAL

1. While purging the system with nitrogen, apply heat and separate the copper tubing at the inlet and outlet connections of the compressor. (See WP 0040 00, LEAK TESTING THE REFRIGERANT R-410A SYSTEM and WP 0042 00, CHARGING THE REFRIGERANT R-410A SYSTEM).
2. Spring tubing up and out of the way.
3. Remove cap nuts (2) and flat washers (3) from top of compressor (1) mounting feet. See Figure 1
4. Carefully slide compressor from housing through rear of the compressor assembly.

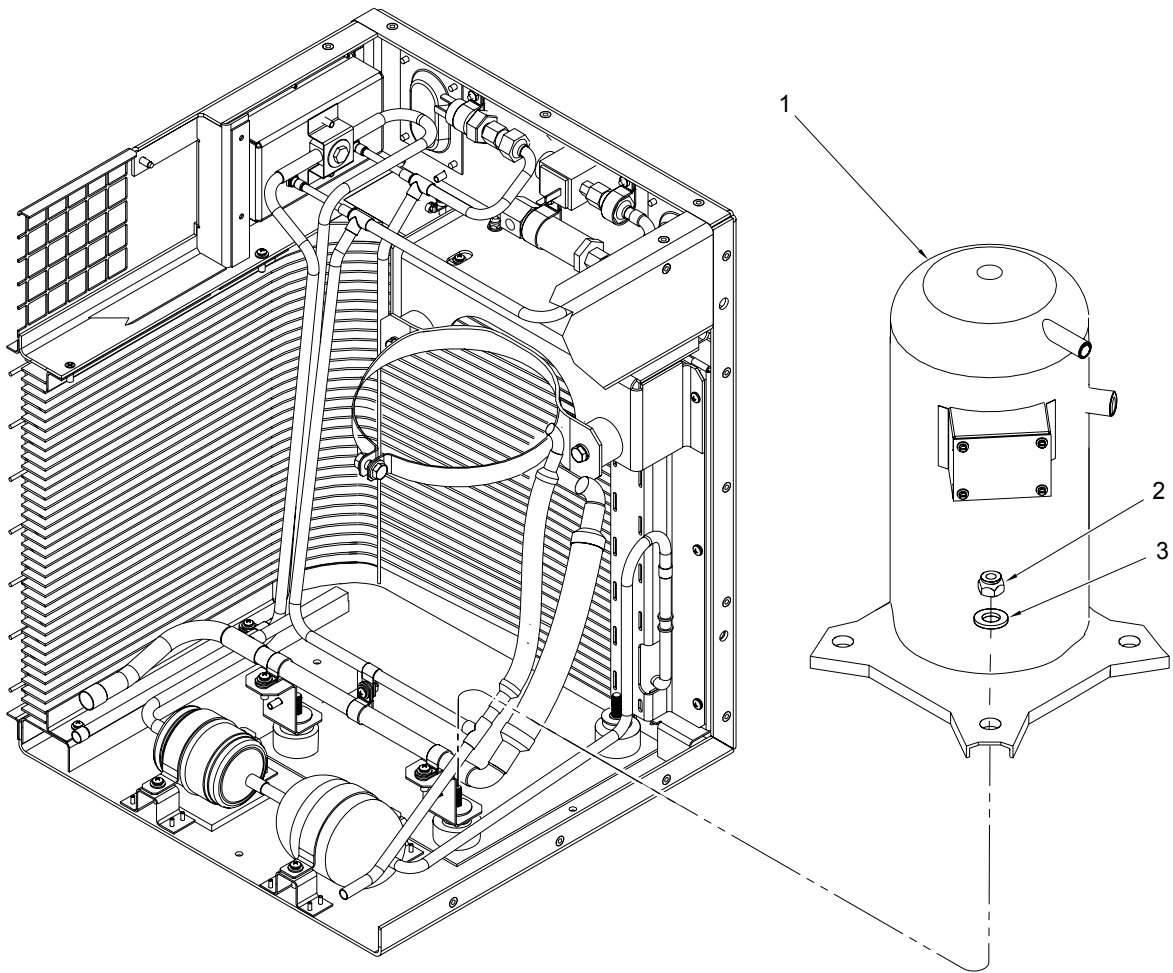
**Figure 1. COMPRESSOR ASSEMBLY.**

WARNING

If compressor burnout is suspected, use care when handling compressor to avoid touching compressor sludge. Acid in sludge can cause burns. Avoid inhaling fumes and burns from any acid formed by burnout of oil and Refrigerant R-410A. Wear protective goggles or glasses to protect eyes. Wear gloves to protect hands. Use care to avoid spilling compressor burnout sludge. If sludge is spilled, clean area thoroughly.

TEST

1. Check the compressor to see if a motor burnout is indicated.
2. After removal of a bad compressor from the refrigeration system, tip the compressor toward the discharge port to drain sample of oil into a clear glass container.
3. If the oil is clean and clear, and does not have a burnt acid smell, the compressor did not fail because of motor burnout. If a burnout is not indicated, proceed to compressor installation.
4. If the oil is black, contains sludge and has a burnt acid odor, the compressor failed because of motor burnout.
5. You must clean the entire refrigeration system after a burnout has occurred, since contaminants will have been carried to many corners and restrictions in the piping and fittings. These contaminants will soon mix with new Refrigerant R-410A gas and compressor oil to cause repeated burnouts.
6. Remove the filter-dryer, (WP 0030 00) and blow down each leg of the refrigeration system. To do this, connect a cylinder of dry-nitrogen to each filter-drier connection, in turn, and open the cylinder shutoff valve for at least 30 seconds at 50 psig (3.5 kg/square centimeter) pressure.
7. Connect the two filter-dryer fittings with a jumper, locally manufactured from refrigerant tubing and fittings.
8. Clean system by back flushing with liquid CF-20 from circulating pump and reservoir with pressure of at least 100 psig.
9. If pump is used, connect the discharge line of the Refrigerant R-410A system to the discharge side of pump.

NOTE

An unused filter-dryer or other suitable medium may be used as the filter.

10. Connect a line containing a filter to the suction line in the unit.

11. The other end of the temporary suction line should be connected to a small drum or suitable reservoir.
12. A line should be run from the bottom of the reservoir to the inlet of the pump.
13. Fill reservoir with Refrigerant CF-20, and start the pump. Continue filling the reservoir with Refrigerant, CF-20, until it begins to pour out of the return line. Continue flushing for at least 15 minutes.
14. Reverse the pump connections, replace the filter with a new filtering medium, and back flush the system for an additional 15 minutes.
15. Remove the pump, reservoir, filter, and filter-dryer jumper. Place an empty container below the compressor connections and connect a cylinder of dry nitrogen to each filter-dryer connection in turn. Blow down each leg of the system at 50 psig (3.5 kg/square centimeter) for at least 30 seconds.
16. Disconnect the dry nitrogen cylinder. Cap or plug open connections if compressor and filter-dryer are not to be installed immediately.

INSTALLATION

NOTE

If any refrigeration piping was disconnected with the compressor being replaced, transfer the piping to the replacement compressor before installing it in the ECU.

1. Slide compressor into condenser housing.
2. Secure the compressor with four nuts, lockwashers, and flat washers.
3. To obtain proper loading, tighten nuts until contact is made with all parts. Then turn nut head 2-1/2 to 3-1/2 more turns.
4. Wrap wet rags around compressor at connection points and while brazing, direct flame away from compressor.
5. While purging the system with nitrogen, braze the tubing joints. (See WP 0040 00, LEAK TESTING THE REFRIGERANT R-410A SYSTEM and WP 0043 00, BRAZING/DEBRAZING PROCEDURES).
6. Replace the filter-dryer with new filter-dryer. (See WP 0030 00, FILTER-DRYER REFRIGERANT).
7. Connect wiring to terminals T1 through T3 on the compressor. Replace cover.
8. Charge the R-410A refrigerant system. (See WP 0042 00, CHARGING THE REFRIGERANT R-410A SYSTEM)
9. Leak test all newly connected joints and those in the repair area. (See WP 0040 00, LEAK TESTING THE REFRIGERANT R-410A SYSTEM).
10. Evacuate and charge the Refrigerant R-410A system. (See WP 0041 00, EVACUATING THE REFRIGERANT R-410A SYSTEM and WP 0043 00, BRAZING/DEBRAZING PROCEDURES).
11. Install rear condenser cover. (See WP 0025 00, CONDENSER COVERS).
12. Install top condenser cover. (See WP 0025 00, CONDENSER COVER).

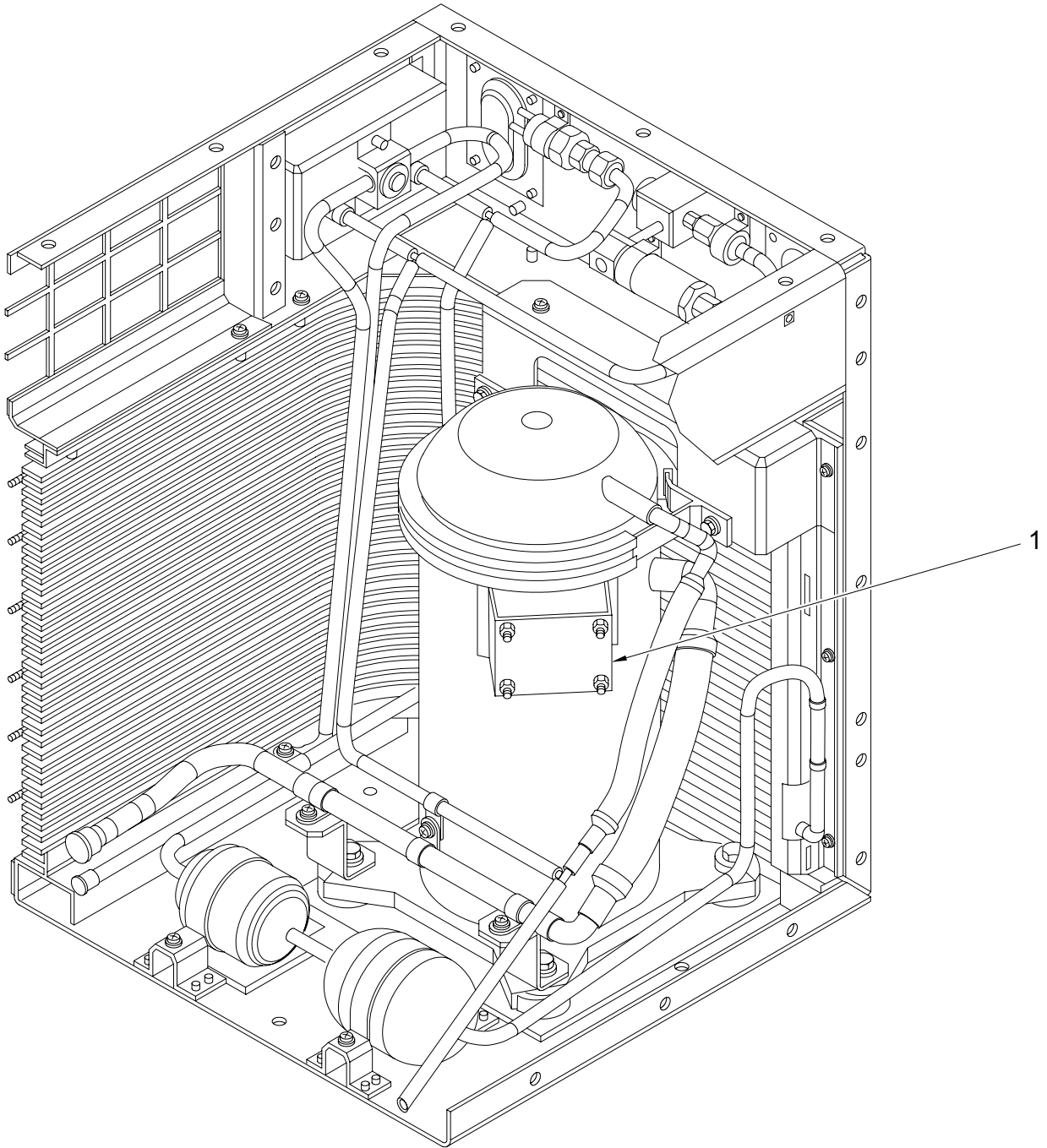

Figure 2. COMPRESSOR ASSEMBLY - INSTALLED.

END OF WORK PACKAGE

FIELD LEVEL

24,000 BTUH, SPLIT PACK ENVIRONMENTAL CONTROL UNIT (ECU)

NSN 4120-01-516-4715 F24H4-2

REMOTE CONTROL ASSEMBLY

0035 00

INITIAL SETUP:

Personnel Required

Unit level Technician (1)

Equipment Condition

Power disconnected

Tools And Special Tools

Tool Kit, Refrigeration Ordnance
5180-00-596-1474

References

TM 9-4120-429-24P

Materials/Parts

Remote control assembly 001T0010-1 (1)

NOTE

The remote control unit is a non-repairable component. Faulty devices should be disposed of following appropriate property disposal methods.

REMOTE CONTROL UNIT

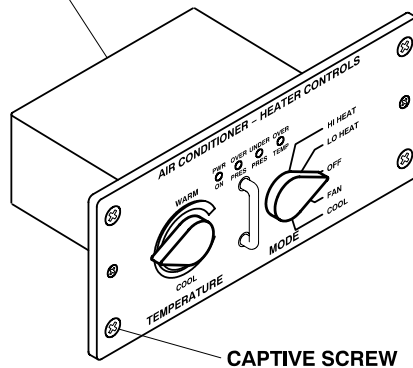

Figure 1. REMOTE CONTROL UNIT.

INSPECTION

1. Visually inspect the remote control unit for dents, cracks and mounting hardware in place.

2. Inspect knobs for tightness. Rotate knobs to insure movement.

REMOVAL

1. Unscrew captive screws in corners of remote control assembly.
2. Pull remote control assembly out from rack where installed to gain access to cable connector on rear.
3. Disconnect cable connector from remote control assembly.
4. Remove remote control assembly.

INSTALLATION

1. Position remote control in front of opening in equipment rack in shelter.
2. Connect cable connector to connector on rear of remote control assembly.
3. Slip remote control assembly into place on rack.
4. Secure remote control to rack with captive screws.
5. Connect power.

TEST

1. Position remote control unit on a flat surface with access to plug connector P2.
2. Set multimeter to read a diode forward bias resistance.
3. Connect negative multimeter lead to P2, pin L and positive multimeter lead to P2, pin E. Check for resistance reading.
4. Connect negative multimeter lead to P2, pin K and positive multimeter lead to P2, pin E. Check for resistance reading.
5. Connect negative multimeter lead to P2, pin J and positive multimeter lead to P2, pin E. Check for resistance reading.
6. Connect negative multimeter lead to P2, pin J and positive multimeter lead to P2, pin F. Check for resistance reading.
7. If readings in 3 through 6 indicate an open or short condition, replace the remote control unit.

END OF WORK PACKAGE

FIELD LEVEL

24,000 BTUH, SPLIT PACK ENVIRONMENTAL CONTROL UNIT (ECU)

NSN 4120-01-516-4715

F24H4-2

CONDENSER HARNESS ASSEMBLIES

0036 00

INITIAL SETUP:

Wiring Harness 178K0103-1 (1)

Wiring Harness 178K0129-1 (1)

Personnel Required

Unit Level Technician (1)

Equipment Condition

ECU removed from shelter (See WP 0005 00, INSTALLATION SITE PREPARATION).

Covers removed (See WP 0025 00, CONDENSER COVERS).

Tools And Special Tools

Tool Kit, Refrigeration Ordnance
5180-00-596-1474

Materials/Parts

Wiring Harness 178K0101-1 (1)

Wiring Harness 178K0102-1 (1)

References

TM 9-4120-429-24P

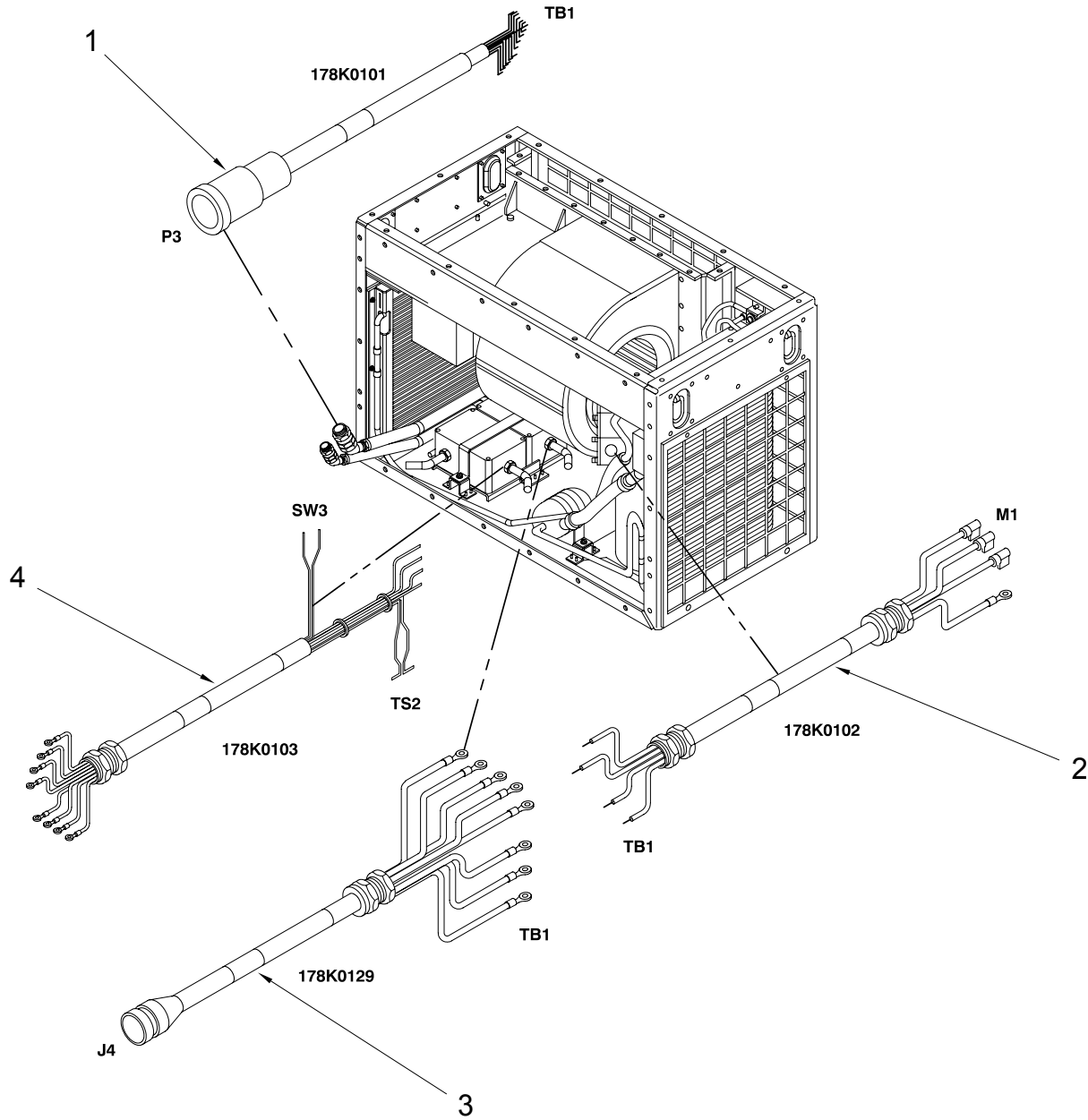

Figure 1. CONDENSER HARNESS ASSEMBLIES.

REMOVAL

1. To remove P3 wiring harness (1), disconnect P3 connector plug at evaporator access box.
2. Remove screw, nut, and clamp.
3. Tag and remove leads to terminal board TB1 and ground E3.
4. To remove J4 wiring harness (3), disconnect J4 from P4 connector plug.
5. Remove wire leads from terminals FL3 through FL10 inside of the junction box assembly. (See WP 0024 00, JUNCTION BOX ASSEMBLY).
6. Tag and remove leads to terminal board FL11 through FL14 inside of junction box. (See WP 0024 00, JUNCTION BOX ASSEMBLY).
7. Disconnect leads from terminals on SW4, SW5 and SW6. Cut wires from TS2. Remove harness (4). (See Figure 2).
8. Tag and remove leads to terminal board TB1 - 1, 2 4, and 17. (See WP 0045 00, Figure 1).
9. To remove P10, P11, and P13 harness (2), disconnect P10 connector plug from compressor.
10. Disconnect leads from compressor terminals T1, T2, T3 and ground located on compressor.

REPAIR OR REPLACEMENT

1. See WP 0037 00, ELECTRICAL WIRING REPAIR GENERAL for general wire repair instructions.
2. See WP 0038 00, Wire List, for wire lengths and terminals information when individual wires are replaced.

INSTALLATION

1. To install P3 wiring harness (1), connect P3 to J3 at evaporator access box.
2. See tags, wire marking, and wiring diagram.
3. Install leads on terminal board TB3 and ground E3. Remove tags.
4. Install clamp, screw and nut.
5. To install J4 wiring harness (3), connect P4.
6. See tags, wire marking, and wiring diagram.
7. Install leads on terminal board to FL3 through FL10 in the junction box assembly. (See WP 0024 00, JUNCTION BOX ASSEMBLY). Remove tags.
8. To install TB1 harness (2), connect leads to terminals 1 through 17 and ground inside of the junction box assembly. (See WP 0024 00, JUNCTION BOX ASSEMBLY).
9. Connect M1 leads to terminals located on the compressor assembly. (See WP 0034 00, COMPRESSOR ASSEMBLY).
10. See tags, wire marking, and wiring diagram.
11. Install leads on terminal board to FL11 through FL14 located inside of the junction box assembly. (See WP 0024 00, JUNCTION BOX ASSEMBLY) Remove tags.
12. To install lead SW6 and TS2 see tags, wire marking, and wiring diagram.
13. Install remaining leads to terminals on SW4 and SW5. Remove tags.
14. Install top condenser cover. (See WP 0025 00, CONDENSER COVERS).
15. Install front condenser cover. (See WP 0025 00, CONDENSER COVERS).

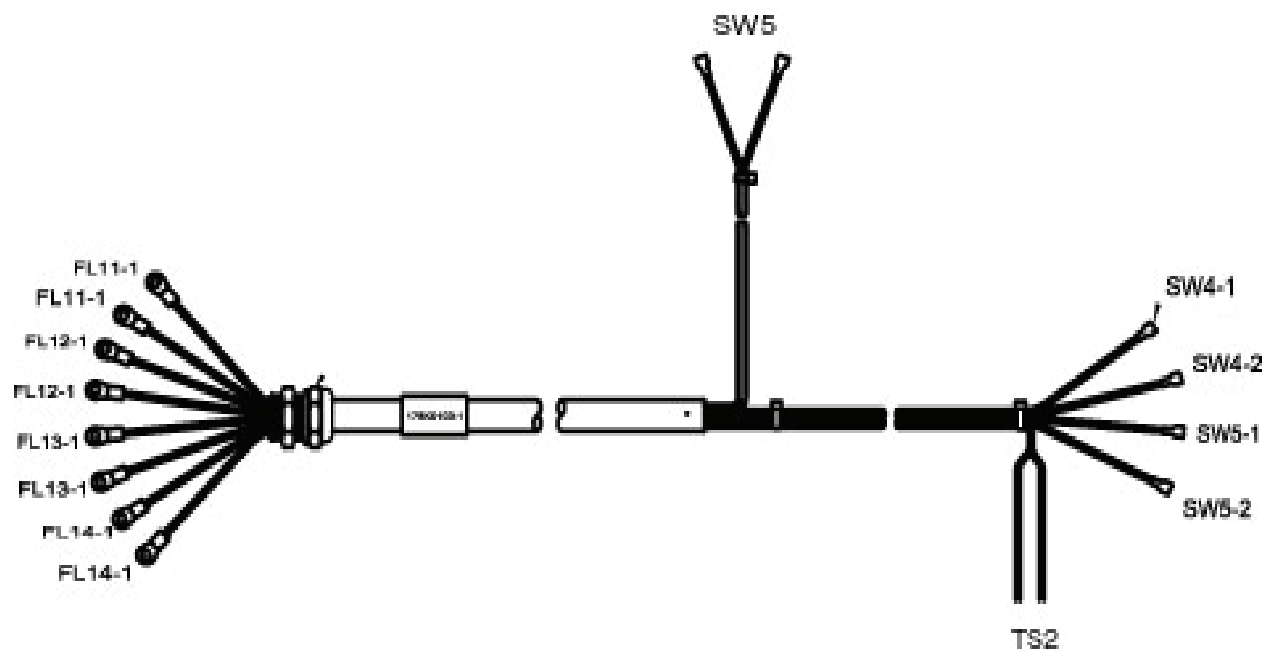

Figure 2. HARNESS ASSEMBLY

FIELD LEVEL

24,000 BTUH, SPLIT PACK ENVIRONMENTAL CONTROL UNIT (ECU)

NSN 4120-01-516-4715

F24H4-2

ELECTRICAL WIRING REPAIR GENERAL

0037 00

INITIAL SETUP:

Personnel Required

Unit Level Technician (1)

Tools And Special Tools

Tool Kit, Refrigeration Ordnance
5180-00-596-1474

Materials/Parts

Flux O-F-499, Type B (1)
Solder, Lead-Tin QQ-S-571, Type SN60WRP2 (1)
Tape, Lacing MIL-T-43435 (1)

Equipment Condition

Air conditioner removed from shelter (See WP 0005 00, INSTALLATION SITE PREPARATION).
Evaporator and condenser section assemblies separated (See WP 0012 00, EVAPORATOR/CONDENSER ASSEMBLY-SEPARATION AND RECONNECTION) required access covers removed.

References

TM 9-4120-429-24P

REPAIR OR REPLACEMENT

1. Preferred repair methods consist of replacing wires, terminals, connectors, etc., rather than splicing wires, bending ends to form terminals, and other makeshift procedures, although the latter may be appropriate for emergency field repairs. Determine the proper size and length of wire, or the terminal, or connector to be used for replacement by referring to the wiring diagram and to the wire list (See WP 0038 00, WIRE LIST).
2. Soldering Connections. Wire connections must be made mechanically sound before they are soldered; solder alone does not provide sufficient strength to prevent breakage. Joining surfaces of connections to be soldered must be clean and bright. If a separate flux is used, it should conform to Specification O-F-499, Type B, silver brazing flux, and should be brushed onto the joint before soldering. If a flux-core solder is used, it should always be rosin-core electrical solder. If an uncured solder is used, it should be a lead-tin solder conforming to specification QQ-S-571 Type SN60WRP2. Wires should always be heated to the point at which the solder will melt completely and flow into all parts of the joint. Excessive build-up of solder *gobs* on the joint and should be avoided or removed.

3. Securing Wire Bundles. Use lacing tape per MIL-T-43435 to tie wire into bundles.
4. Splicing Wires. To repair broken or cut wires that are otherwise sound, the mating ends can be stripped and spliced. A commercial butt splice can be crimped onto the ends to join them, or a *Western Union* wire splice can be made. The latter is made by stripping 1/4- 1/2 inch (0.6 - 1.3 cm) of insulation from the wire ends, holding the ends parallel and facing opposite directions, then twisting each end around the other wire at least three turns. Solder and apply insulation as described above.
5. Crimping Terminals. To install a terminal on the end of a wire, strip 1/4- 1/2 inch (0.6 - 1.3 cm) of insulation from the end of the wire, insert wire end into the shank of the terminal, and crimp the shank.

END OF WORK PACKAGE

FIELD LEVEL

24,000 BTUH, SPLIT PACK ENVIRONMENTAL CONTROL UNIT (ECU)

NSN 4120-01-516-4715

F24H4-2

WIRE LIST

0038 00

INSPECTION-ACCEPTANCE AND REJECTION CRITERIA

Table 1. WIRING LIST

TERMININATION				AWG WIRE SIZE	LENGTH	
PART NUMBER	FROM	TO	WIRE COLOR		IN.	CM.
178K0101-1	P3	TB1				
M22759/16-12-90	P3-A	TB1-1	WH/BLK	16	22.00	55.88
M22759/16-12-92	P3-B	TB1-2	WH/RED	16	22.00	55.88
M22759/16-16-4	P3 -C	TB1-3	YELLOW	16	22.00	55.88
M22759/16-12-96	P3-D	TB1-4	WH/BLUE	16	22.00	55.88
M22759/16-12-0	P3-E	TB1-5	BLACK	16	22.00	55.88
M22759/16-16-4	P3-F	TB1-6	YELLOW	16	22.00	55.88
M22759/16-16-4	P3-G	TB1-7	YELLOW	16	22.00	55.88
M22759/16-16-4	P3-H	TB1-8	YELLOW	16	22.00	55.88
M22759/16-16-4	P3-J	TB1-9	YELLOW	16	22.00	55.88
M22759/16-16-4	P3-K	TB1-10	YELLOW	16	22.00	55.88
M22759/16-12-2	P3-L	TB1-11	RED	16	22.00	55.88
M22759/16-12-6	P3-M	TB1-12	BLUE	16	22.00	55.88

Table 1. WIRING LIST (continued)

TERMINATION				AWG WIRE SIZE	LENGTH	
PART NUMBER	FROM	TO	WIRE COLOR		IN.	CM.
M22759/16-16-4	P3-N 16	TB1-13	YELLOW	16	22.00	55.88
M22759/16-12-0	P3-P	TB1-14	BLACK	16	22.00	55.88
M22759/16-12-2	P3-R	TB1-15	RED	16	22.00	55.88
M22759/16-12-6	P3-S	TB1-16	BLUE	16	22.00	55.88
M22759/16-12-5	P3-T	TB1-17	GREEN	16	22.00	55.88
178K0102-1	TB1	M1				
M22759/16-12-90	TB1-1	M1-T1	WH/BLK	16	40.00	101.60
M22759/16-12-92	TB1-2	M1-T2	WH/RED	16	40.00	101.60
M22759/16-12-96	TB1-4	M1-T3	WH/BLUE	16	40.00	101.60
M22759/16-12-5	TB1-17	M1-GND	GREEN	16	40.00	101.60
178K0103-1	FL	SW/TS2				
M22759/16-18-4	FL11-1	SW6-1		16	54.00	137.16
M22759/16-18-4	FL11-1	SW4-1		16	74.00	187.96
M22759/16-18-4	FL12-1	SW4-2		16	74.00	187.96

Table 1. WIRING LIST (continued)

TERMINATION				AWG WIRE SIZE	LENGTH	
PART NUMBER	FROM	TO	WIRE COLOR		IN.	CM.
M22759/16-18-4	FL12-1	SW5-1		16	74.00	187.96
M22759/16-18-4	FL13-1	SW5-2		16	74.00	187.96
M22759/16-18-4	FL14-1	SW6-2		16	54.00	137.16
M22759/16-18-4	FL13-1	TS2-1		16	72.00	182.88
M22759/16-18-4	FL14-1	TS2-2		16	72.00	182.88
178K0104-1	FL	TB1				
M22759/16-16-4	FL3-2	TB1-5	YELLOW	16	4.00	10.16
M22759/16-16-4	FL4-2	TB1-11	YELLOW	16	4.00	10.16
M22759/16-16-4	FL5-2	TB1-12	YELLOW	16	4.00	10.16
M22759/16-16-4	FL6-2	TB1-14	YELLOW	16	4.00	10.16
M22759/16-16-4	FL7-2	TB1-15	YELLOW	16	4.00	10.16
M22759/16-16-4	FL8-2	TB1-16	YELLOW	16	4.00	10.16
M22759/16-16-4	FL9-2	TB1-6	YELLOW	16	4.00	10.16
M22759/16-16-4	FL10-2	TB1-7	YELLOW	16	4.00	10.16

Table 1. WIRING LIST (continued)

TERMINATION				AWG WIRE SIZE	LENGTH	
PART NUMBER	FROM	TO	WIRE COLOR		IN.	CM.
22759/16-16-4	FL11-2	TB1-8	YELLOW	16	4.00	10.16
M22759/16-16-4	FL12-2	TB1-9	YELLOW	16	4.00	10.16
M22759/16-16-4	FL13-2	TB1-10	YELLOW	16	4.00	10.16
M22759/16-16-4	FL14-2	TB1-13	YELLOW	16	4.00	10.16
178K0105-1	FL1	CB1				
M22759/16-8-0	FL1-LDA	CB1-LINE 1	BLACK	16	22.00	55.88
M22759/16-8-2	FL1-LDB	CB1-LINE 2	RED	16	22.00	55.88
M22759/16-8-6	FL1-LDC	CB1-LINE 3	BLUE	16	22.00	55.88
178K0106-1	J1	FL1				
M22759/16-8-0	J1-A	FL1-A	BLACK	16	18.00	45.72
M22759/16-8-2	J1-B	FL1-B	RED	16	18.00	45.72
M22759/16-8-6	J1-C	FL1-C	BLUE	16	18.00	45.72
M22759/16-8-9	J1-D	FL1-N	WHITE	16	18.00	45.72
178K0107-1	J2	P102/E6				

Table 1. WIRING LIST (continued)

TERMINATION				AWG WIRE SIZE	LENGTH	
PART NUMBER	FROM	TO	WIRE COLOR		IN.	CM.
M22759/16-20-4	J2-A	P102-1	YELLOW	16	42.00	106.68
M22759/16-20-4	J2-B	P102-2	YELLOW	16	42.00	106.68
M22759/16-20-4	J2-C	P102-3	YELLOW	16	42.00	106.68
M22759/16-20-4	J2-D	P102-4	YELLOW	16	42.00	106.68
M22759/16-20-4	J2-E	P102-5	YELLOW	16	42.00	106.68
M22759/16-20-4	J2-F	P102-6	YELLOW	16	42.00	106.68
M22759/16-20-4	J2-G	P102-7	YELLOW	16	42.00	106.68
M22759/16-20-4	J2-H	P102-8	YELLOW	16	42.00	106.68
M22759/16-20-4	J2-J	P102-9	YELLOW	16	42.00	106.68
M22759/16-20-4	J2-K	P102-10	YELLOW	16	42.00	106.68
M22759/16-20-4	J2-L	P102-11	YELLOW	16	42.00	106.68
M22759/16-16-5	J2-M	E6	GREEN	16	8.00	20.32
178K0108-1	J3	VFD1/J8 and P106/E4				
M22759/16-12-90	J3-A	VFD1-T1	WH/BLK	16	16.00	40.64

Table 1. WIRING LIST (continued)

TERMINATION				AWG WIRE SIZE	LENGTH	
PART NUMBER	FROM	TO	WIRE COLOR		IN.	CM.
M22759/16-20-4	J2-A	P102-1	YELLOW	16	42.00	106.68
M22759/16-20-4	J2-B	P102-2	YELLOW	16	42.00	106.68
M22759/16-20-4	J2-C	P102-3	YELLOW	16	42.00	106.68
M22759/16-20-4	J2-D	P102-4	YELLOW	16	42.00	106.68
M22759/16-20-4	J2-E	P102-5	YELLOW	16	42.00	106.68
M22759/16-20-4	J2-F	P102-6	YELLOW	16	42.00	106.68
M22759/16-20-4	J2-G	P102-7	YELLOW	16	42.00	106.68
M22759/16-20-4	J2-H	P102-8	YELLOW	16	42.00	106.68
M22759/16-20-4	J2-J	P102-9	YELLOW	16	42.00	106.68
M22759/16-20-4	J2-K	P102-10	YELLOW	16	42.00	106.68
M22759/16-20-4	J2-L	P102-11	YELLOW	16	42.00	106.68
M22759/16-16-5	J2-M	E6	GREEN	16	8.00	20.32
178K0108-1	J3	VFD1/J8 and P106/E4				
M22759/16-12-90	J3-A	VFD1-T1	WH/BLK	16	16.00	40.64

Table 1. WIRING LIST (continued)

TERMINATION				AWG WIRE SIZE	LENGTH	
PART NUMBER	FROM	TO	WIRE COLOR		IN.	CM.
M22759/16-12-92	J3- B	VFD1-T2	WH/RED	16	16.00	40.64
M22759/16-12-96	J3-D	VFD1-T3	WH/BLUE	16	16.00	40.64
M22759/16-12-0	J3-E	J8-1	BLACK	16	22.00	55.88
M22759/16-12-2	J3-L	J8-2	RED	16	22.00	55.88
M22759/16-12-6	J3-M	J8-3	BLUE	16	22.00	55.88
M22759/16-12-0	J3-P	J8-4	BLACK	16	22.00	55.88
M22759/16-12-2	J3-R	J8-5	RED	16	22.00	55.88
M22759/16-12-6	J3-S	J8-6	BLUE	16	22.00	55.88
M22759/16-20-4	J3-F	P106-1	YELLOW	16	40.00	101.60
M22759/16-20-4	J3-G	P106-2	YELLOW	16	40.00	101.60
M22759/16-20-4	J3-H	P106-3	YELLOW	16	40.00	101.60
M22759/16-20-4	J3-J	P106-4	YELLOW	16	40.00	101.60
M22759/16-20-4	J3-K	P106-5	YELLOW	16	40.00	101.60
M22759/16-20-4	J3-N	P106-6	YELLOW	16	40.00	101.60

Table 1. WIRING LIST (continued)

TERMINATION				AWG WIRE SIZE	LENGTH	
PART NUMBER	FROM	TO	WIRE COLOR		IN.	CM.
M22759/16-12-2	J3- B	VFD1-T2	WH/RED	16	16.00	40.64
M22759/16-12-6	J3-D	VFD1-T3	WH/BLUE	16	16.00	40.64
M22759/16-12-0	J3-E	J8-1	BLACK	16	22.00	55.88
M22759/16-12-2	J3-L	J8-2	RED	16	22.00	55.88
M22759/16-12-6	J3-M	J8-3	BLUE	16	22.00	55.88
M22759/16-12-0	J3-P	J8-4	BLACK	16	22.00	55.88
M22759/16-12-2	J3-R	J8-5	RED	16	22.00	55.88
M22759/16-12-6	J3-S	J8-6	BLUE	16	22.00	55.88
M22759/16-20-4	J3-F	P106-1	YELLOW	16	40.00	101.60
M22759/16-20-4	J3-G	P106-2	YELLOW	16	40.00	101.60
M22759/16-20-4	J3-H	P106-3	YELLOW	16	40.00	101.60
M22759/16-20-4	J3-J	P106-4	YELLOW	16	40.00	101.60
M22759/16-20-4	J3-K	P106-5	YELLOW	16	40.00	101.60
M22759/16-20-4	J3-N	P106-6	YELLOW	16	40.00	101.60

Table 1. WIRING LIST (continued)

TERMINATION				AWG WIRE SIZE	LENGTH	
PART NUMBER	FROM	TO	WIRE COLOR		IN.	CM.
178K0109-1	J5	K1/E2/P 104				
M22759/16-12-0	J5-1	K1-T1	BLACK	16	21.00	53.34
M22759/16-12-2	J5-2	K1-T2	RED	16	21.00	53.34
M22759/16-12-6	J5-3	K1-T3	BLUE	16	21.00	53.34
M22759/16-12-5	J5-4	E2	GREEN	16	12.00	30.48
M22759/16-20-4	J5-5	P104-1	YELLOW	16	24.00	60.96
M22759/16-20-4	J5-6	P104-2	YELLOW	16	24.00	60.96
178K0110-1	CB1/E1	J6				
M22759/16-10-0	CB1- LOAD-1	J6-1	BLACK	16	28.00	71.12
M22759-16-10-2	CB1- LOAD-2	J6-2	RED	16	28.00	71.12
M22759/16-10-6	DB1- LOAD-3	J6-3	BLUE	16	28.00	71.12
M22759/16-10-5	E1	J6-4	GREEN	16	30.00	76.20
178K0111-1	P6	K2/E2				
M22759/16-10-0	P6-1	K2-L1	BLACK	16	13.00	33.02

Table 1. WIRING LIST (continued)

TERMINATION				AWG WIRE SIZE	LENGTH	
PART NUMBER	FROM	TO	WIRE COLOR		IN.	CM.
M22759/16-10-2	P6-2	K2-L2	RED	16	13.00	33.02
M22759/16-10-6	P6-3	K2-L3	BLUE	16	13.00	33.02
M22759/16-10-5	P6-4	E2	GREEN	16	15.00	38.10
178K0112-1	J7	K2/K3				
M22759/16-12-0	J7-1	K2-T1	BLACK	16	14.00	35.56
M22759/16-12-2	J7-2	K2-T2	RED	16	14.00	35.56
M22759/16-12-6	J7-3	K2-T3	BLUE	16	14.00	35.56
M22759/16/12-0	J7-4	K3-T1	BLACK	16	20.50	52.07
M22759/16-12-2	J7-5	K3-T2	RED	16	20.50	52.07
M22759/16-12-6	J7-6	K3-T3	BLUE	16	20.50	52.07
178K0113-1	P7	HR				
M22759/16-12-0	P7-1	HR1-1	BLACK	16	22.00	55.88
M22759/16-12-2	P7-2	HR2-1	RED	16	22.00	55.88
M22759/16-12-6	P7-3	HR3-1	BLUE	16	22.00	55.88

Table 1. WIRING LIST (continued)

TERMINATION				AWG WIRE SIZE	LENGTH	
PART NUMBER	FROM	TO	WIRE COLOR		IN.	CM.
M22759/16-12-0	P7-4	HR4-1	BLACK	16	22.00	55.88
M22759/16-12-2	P7-5	HR5-1	RED	16	22.00	55.88
M22759/16-12-6	P7-6	HR6-1	BLUE	16	22.00	55.88
178K0114-1	P8	K5/K6				
M22759/16-12-0	P8-1	K5-T1	BLACK	16	26.00	66.04
M22759/16-12-2	P8-2	K5-T2	RED	16	26.00	66.04
M22759/16-12-6	P8-3	K5-T3	BLUE	16	26.00	66.04
M22759/16-12-0	P8-4	K6-T1	BLACK	16	23.00	58.42
M22759/16-12-2	P8-5	K6-T2	RED	16	23.00	58.42
M22759/16-12-6	P8-6	K6-T3	BLUE	16	23.00	58.42
178K0115-1	P9	K4				
M22759/16-12-0	P9-1	K4-T1	BLACK	16	16.00	40.64
M22759/16-12-2	P9-2	K4-T2	RED	16	16.00	40.64
M22759/16-12-6	P9-3	K4-T3	BLUE	16	16.00	40.64

Table 1. WIRING LIST (continued)

TERMINATION				AWG WIRE SIZE	LENGTH	
PART NUMBER	FROM	TO	WIRE COLOR		IN.	CM.
178K0116-1	J9/FL2	FL2/VFD 1				
M22759/16-12-0	J9-1	FL2-A1	BLACK	16	21.00	53.34
M22759/16-12-2	J9-2	FL2-B1	RED	16	22.00	55.88
M22759/16-12-6	J9-3	FL2-C1	BLUE	16	23.00	58.42
M22759/16-12-0	FL2-A2	VFD1-L1	BLACK	16	15.00	38.10
M22759/16-12-2	FL2-B2	VFD1-L2	RED	16	14.00	35.56
M22759/16-12-6	FL2-C3	VFD1-L3	BLU E	16	13.00	33.02
178K0117-1	K2/K3/ K4/K5 /K6	K4/K1/ K6/K3 /K5				
M22759/16-12-0	K2-L1	K4-L1	BLACK	16	10.25	26.04
M22759/16-12-2	K2-L2	K4-L2	RED	16	10.25	26.04
M22759/16-12-6	K2-L3	K4-L3	BLUE	16	10.25	26.04
M22759/16-12-0	K3-L1	K1-L1	BLACK	16	10.75	27.31
M22759/16-12-2	K3-L2	K1-L2	RED	16	10.75	27.31
M22759/16-12-6	K3-L3	K1-L3	BLUE	16	10.75	27.31

Table 1. WIRING LIST (continued)

TERMINATION				AWG WIRE SIZE	LENGTH	
PART NUMBER	FROM	TO	WIRE COLOR		IN.	CM.
M22759/16-12-0	K4-L1	K6-L1	BLACK	16	10.25	26.04
M22759/16-12-2	K4-L2	K6-L2	RED	16	10.25	26.04
M22759/16-12-6	K4-L3	K6-L3	BLUE	16	10.25	26.04
M22759/16-12-0	K5-L1	K3-L1	BLACK	16	10.75	27.31
M22759/16-12-2	K5-L2	K3-L2	RED	16	10.75	27.31
M22759/16-12-6	K5-L3	K3-L3	BLUE	16	10.75	27.31
M22759/16-12-0	K6-L1	K5-L1	BLACK	16	15.25	38.74
M22759/16-12-2	K6-L2	K5-L2	RED	16	15.25	38.74
M22759/16-12-6	K6-L3	K5-L3	BLUE	16	15.25	38.74
178K0118-1	P101	P10/FL1/ E6				
M22759/16-20-4	P101-1	P10-1	YELLOW	16	38.00	96.52
M22759/16-20-4	P101-2	P10-2	YELLOW	16	38.00	96.52
M22759/16-20-4	P101-3	P10-3	YELLOW	16	38.00	96.52
M22759/16-20-4	P101-4	P10-4	YELLOW	16	38.00	96.52

Table 1. WIRING LIST (continued)

TERMINATION				AWG WIRE SIZE	LENGTH	
PART NUMBER	FROM	TO	WIRE COLOR		IN.	CM.
M22759/16-20-4	P104 - 12	K5-A2	YELLOW	16	21.00	53.34
M22759/16-20-4	P104-13	K6-A2	YELLOW	16	24.00	60.96
M22759/16-20-4	P104-14	K6-A1	YELLOW	16	24.00	60.96
M22759/16-20-0	P104-16	K1-L1	BLACK	16	27.00	68.58
M22759/16-20-2	P104-18	K1-L2	RED	16	27.00	68.58
178K0120-1	P105/P S1/K7/ SW2	SW2/SW 3/K7/PS 1/T1/K7/ SW3				
M22759/16-20-4	P105-1	SW2-1	YELLOW	16	31.00	78.74
M22759/16-20-4	P105-2	SW3-2	YELLOW	16	31.00	78.74
M22759/16-20-4	P105-4	K7-15	YELLOW	16	23.00	58.42
M22759/16-20-4	P105-5	K7-1	YELLOW	16	23.00	58.42
M22759/16-20-4	P105-6	PS1	YELLOW	16	26.00	66.04
M22759/16-20-0	P105-8	T1-1	BLACK	16	26.00	66.04
M22759/16-20-2	P105-10	T1-2	RED	16	26.00	66.04
M22759/16-20-4	P105-12	T1-5	YELLOW	16	24.00	60.96

Table 1. WIRING LIST (continued)

TERMINATION				AWG WIRE SIZE	LENGTH	
PART NUMBER	FROM	TO	WIRE COLOR		IN.	CM.
M22759/16-2 0-4	P105-13	T1-6	YELLOW	16	24.00	60.96
M22759/16-2 0-4	P105-14	T1-7	YELLOW	16	24.00	60.96
M22759/16-2 0-4	PS1+	K7-16	YELLOW	16	37.00	93.98
M22759/16-2 0-4	PS1-	K7-4	YELLOW	16	37.00	93.98
M22759/16-2 0-4	K7-1	K7-7	YELLOW	16	6.00	15.24
M22759/16-2 0-4	K7-6	K7-15	YELLOW	16	6.00	15.24
M22759/16-2 0-4	K7-7	K7-16	YELLOW	16	6.00	15.24
M22759/16-2 0-4	SW2-2	SW3-1	YELLOW	16	8.00	20.32
178K0121-1	P107	K1/K2/ K3/K4/ K5/K6				
M22759/16-2 0-0	P107-1	K1-T1	BLACK	16	TBD	
M22759/16-2 0-0	P107-3	K2-T1	BLACK	16	TBD	
M22759/16-2 0-0	P107-5	K3-T1	BLACK	16	TBD	
M22759/16-2 0-0	P107-7	K5-T1	BLACK	16	TBD	
M22759/16-2 0-0	P107-9	K6-T1	BLACK	16	TBD	

Table 1. WIRING LIST (continued)

TERMINATION				AWG WIRE SIZE	LENGTH	
PART NUMBER	FROM	TO	WIRE COLOR		IN.	CM.
178K0122-1	P108	VFD1/ RV2/ TS1				
M22759/16-2 0-4	P108-1	VFD1-1	YELLOW	16	46.00	116.84
M22759/16-2 0-4	P108-2	VFD1-2	YELLOW	16	46.00	116.84
M22759/16-2 0-4	P108-3	VFD1- TXA	YELLOW	16	46.00	116.84
M22759/16-2 0-4	P108-4	VFD1- TXB	YELLOW	16	46.00	116.84
M22759/16-2 0-4	P108-5	VFD1-5	YELLOW	16	46.00	116.84
M22759/16-2 0-4	P108-6	VFD1-2	YELLOW	16	46.00	116.84
M22759/16-2 0-4	P108-7	RV2-1	YELLOW	16	50.00	127.00
M22759/16-2 0-4	P108-8	RV2-2	YELLOW	16	50.00	127.00
M22759/16-2 0-4	P108-9	TS1-1	YELLOW	16	32.00	81.28
M22759/16-2 0-4	P108-10	TS1-2	YELLOW	16	32.00	81.28
178K0129-1	J4	FL				
M22759/16-1 6-0	J4-A	FL3-1	BLACK	16	30.00	76.20
M22759/16-1 6-2	J4-B	FL4-1	RED	16	30.00	76.20

Table 1. WIRING LIST (continued)

PART NUMBER	TERMINATION			AWG WIRE SIZE	LENGTH	
	FROM	TO	WIRE COLOR		IN.	CM.
M22759-16-1 6-6	J4-C	FL5-1	BLUE	16	30.00	76.20
M22759/16-1 6-0	J4-D	FL6-1	BLACK	16	30.00	76.20
M22759/16-1 6-2	J4-E	FL7-1	RED	16	30.00	76.20
M22759/16-1 6-6	J4-F	FL8-1	BLUE	16	30.00	76.20
M22759/16-1 6-4	J4-G	FL9-1	YELLOW	16	30.00	76.20
M22759/16-1 6-4	J4-H	FL10-1	YELLOW	16	30.00	76.20

END OF WORK PACKAGE

FIELD LEVEL

24,000 BTUH, SPLIT PACK ENVIRONMENTAL CONTROL UNIT (ECU)

NSN 4120-01-516-4715

F24H4-2

REFRIGERANT R-410A PRESSURE CHECK

0039 00

INITIAL SETUP:

Personnel Required

Direct Support Technician (1)

Tools And Special Tools

Tool Kit, Refrigeration Ordnance

5180-00-596-1474

Equipment Condition

Air conditioner removed from shelter, if necessary

Refrigerant R-410A system discharged (See WP 0041

00, EVACUATING THE REFRIGERANT R-410A SYSTEM) Refrigerant R-410A system purged (See WP 0040 00, LEAK TESTING THE REFRIGERANT R-410A SYSTEM

Any brazing/debrazing procedure completed (See WP 0043 00, BRAZING/DEBRAZING PROCEDURES Refrigerant R-410A system recharged (See WP 0042 00, CHARGING THE REFRIGERANT R-410A SYSTEM

References

OVERHAUL AND RETIREMENT SCHEDULE

Except in cases where it is obvious that the Refrigerant R-410A charge has been lost, the first step in troubleshooting problems in the refrigeration system should be to check discharge and suction pressures under operating conditions. Check pressures as follows:

1. Turn the MODE selector switch to OFF.
2. Connect individual pressure gages, or a refrigeration servicing manifold and hoses to the high (discharge) and low (suction) service valves.
3. Open the low (suction) and high (discharge) service valves.
4. Both gages should read the same. Check the reading with the appropriate column in table below. If the system is even partially charged, the pressure should be approximately equal to that shown in the table for the appropriate ambient temperature. If the pressure is considerably less than shown in the table, the system does not contain enough Refrigerant R-410A to continue the pressure check; go to leak testing (see WP 0040 00, LEAK TESTING THE REFRIGERANT R-410A SYSTEM).
5. Turn the MODE selector switch to the COOL mode with the TEMPERATURE control in the full COOLER setting for a few minutes.
6. With the unit operating, allow gages to stabilize. Take readings of the two gages.
 - a. If discharge and suction pressures are at, or near, the same value, a pressure equalizer solenoid valve L1 malfunction, or an internal compressor failure is indicated.
 - b. If discharge pressure is low and suction pressure is normal, (see table) a low Refrigerant R-410A charge is indicated.
7. If discharge pressure is normal and suction pressure is either high or low, failure or maladjustment of the pressure regulator valve is indicated.

8. If discharge pressure is high and suction pressure is normal, a malfunction of quench valve is indicated.
9. When pressure tests are completed, proceed with the maintenance action indicated.

Table 1. Pressure-Temperature Relationship of Saturated Refrigerant-410A

Temperature		Pressure	
Degrees F	Degrees C	Psig	Kg/cm2
10	-12.3	62.2	4.37
15	-9.4	69.9	4.91
20	-6.6	78.3	5.51
25	-3.8	87.2	6.13
30	-1.1	96.8	6.81
35	1.6	107.1	7.53
40	4.4	118.1	8.31
45	4.2	129.8	9.13
50	10	142.2	10.0
55	12.7	155.5	10.9
60	15.5	169.6	11.9
65	18.3	184.5	12.9
70	21.1	200.4	14.1
75	23.8	217.1	15.2
80	26.6	234.9	16.5
85	29.4	253.7	17.8
90	32.2	273.5	19.2
95	35.0	294.4	20.7
100	37.7	316.4	22.2
105	40.5	339.6	23.8
110	43.3	364.1	25.6
115	46.1	389.9	27.4
120	48.8	416.9	29.3
125	51.6	445.4	31.3
130	54.4	475.4	33.4

Table 1. Pressure-Temperature Relationship of Saturated Refrigerant-410A

Temperature		Pressure	
Degrees F	Degrees C	Psig	Kg/cm2
135	57.2	506.9	35.6
140	60.0	540.1	38.0
145	62.7	575.1	40.0
150	65.5	611.9	43.0
155	68.3	647.8	45.5
160	71.1	683.7	48.1

Table 2. Normal Operating Pressures.

Temperatures	Pressure Range (psig)			
Outdoor Ambient	50F -(10c)	75f (24C)	100F (38C)	120F (49C)
90F (32C) Return Air to Unit (Dry Bulb)	105-125 Suction 290-350 Discharge	120-140 Suction 350-450 Discharge	150-170 Suction 580-640 Discharge	160-180 Suction 620-680 Discharge
80F (27C) Return Air to Unit (Dry Bulb)	100-125 Suction 250-350 Discharge	120-140 Suction 290-390 Discharge	140-160 Suction 550-620 Discharge	150-170 Suction 580-660 Discharge

END OF WORK PACKAGE

FIELD LEVEL

24,000 BTUH, SPLIT PACK ENVIRONMENTAL CONTROL UNIT (ECU)

NSN 4120-01-516-4715

F24H4-2

LEAK TESTING THE REFRIGERANT R-410A SYSTEM

0040 00

INITIAL SETUP:

Personnel Required

Unit Level Technician (1)

Tools And Special Tools

Tool Kit, Refrigeration Ordnance
5180-00-596-1474

Materials/Parts

Nitrogen 6830-00-292-0732 (1)
Refrigerant R-410A 6830-01-523-8775 (1)

Equipment Condition

Air conditioner removed from shelter, if necessary.

Refrigerant R-410A system discharged (See WP 0039 00, REFRIGERANT R-410A PRESSURE CHECK).

Refrigerant R-410A system purged (See LEAK TESTING THE REFRIGERANT R-410A SYSTEM).

Any brazing/debrazing procedure completed (See WP 0043 00, BRAZING/DEBRAZING PROCEDURES).

References

TEST AND INSPECTION

The entire repair area should be thoroughly leak tested after repair or replacement of any component, before it is recharged with Refrigerant-R-410A. Leak testing is also the method for troubleshooting when a system has lost all or part of its Refrigerant R-410A charge through an undetermined cause.

Testing Method. There are two acceptable methods for leak testing the refrigeration system listed below.

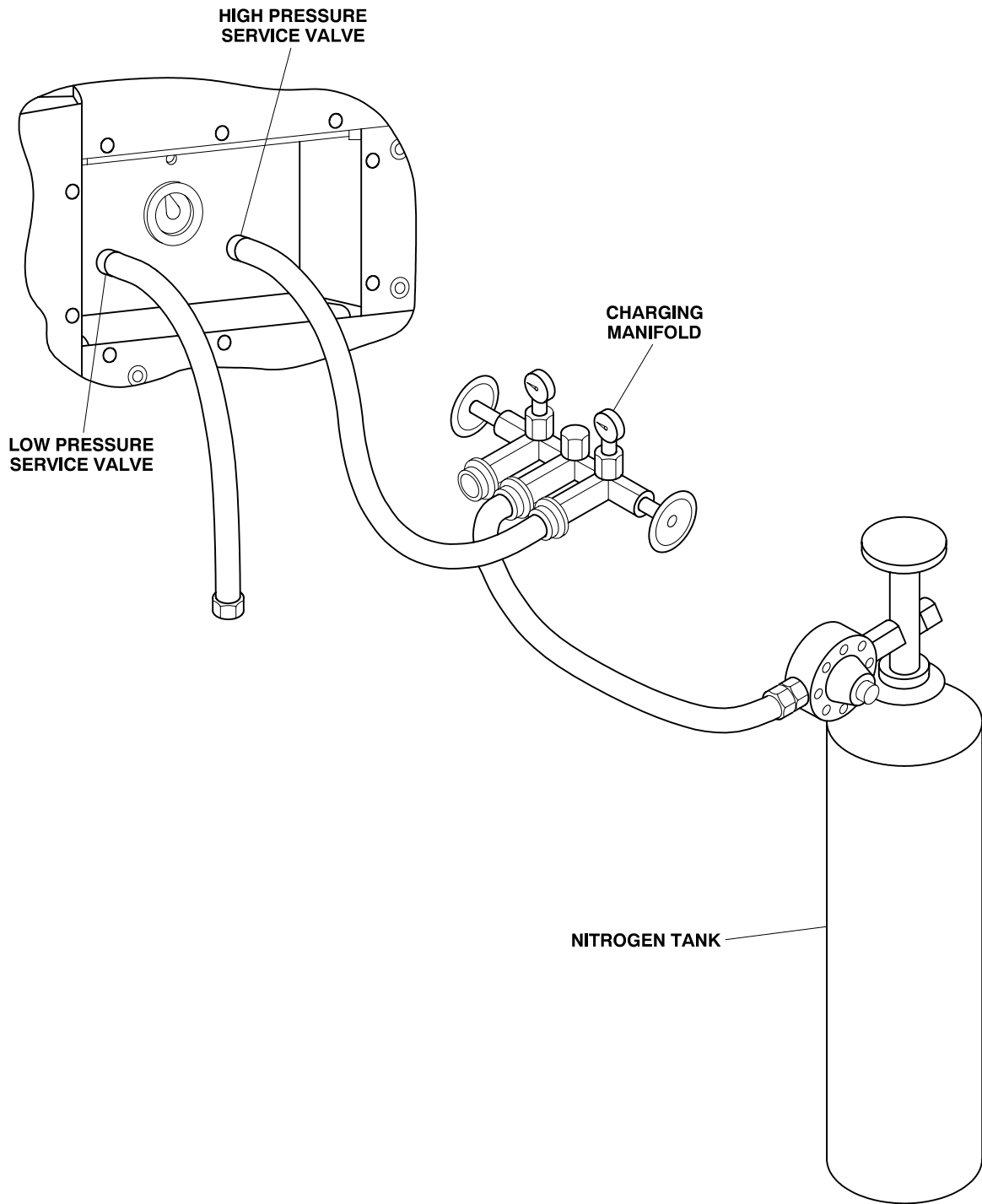

Figure 1. R-410A PURGING.

1. *Refrigerant R-410A gas leak detector.* If an electronic Refrigerant R-410A gas leak detector is available, it should be used in accordance with the procedures contained in this manual, "Leak Testing the Refrigerant R-410A Gas".

NOTE

The electronic Refrigerant R-410A gas leak detector is highly sensitive to the presence of a minute quantity of gas in the air, and due to this factor is quite effective in the detection of small leaks. However, due to the rapid dispersion of Refrigerant R-410A gas into the surrounding air, difficulty may be encountered in pinpointing large leaks. The detector must be used in a well ventilated but draft-free area.

2. *Soap solutions.* In this method, a strong solution of a liquid detergent and water is brushed onto all points of possible leakage while closely observing for the formation of bubbles.

CAUTION

If the soap solution testing method is used, thoroughly rinse with fresh water after testing is completed. A residual soap film will attract and accumulate an excessive amount of dust and dirt during operation.

Testing procedures. To perform leak testing by use of the electronic detector, it is necessary that the system be pressurized with dry nitrogen alone. To pressurize a system that has some Refrigerant R-410A charge, for either leak testing method:

3. Remove the caps from the high and low-pressure service valves.
4. Connect the hoses from a charging manifold to the service valves.

NOTE

If it is possible that the problem may not be a leak and that you may not have to replace a refrigeration system component, Refrigerant-R-410A may be substituted for the nitrogen in the following test. If nitrogen is used, you will have to discharge, evacuate, and recharge the system after this test is completed.

5. Connect a nitrogen pressure regulator and nitrogen bottle to the center hose connection of the charging manifold.
6. Open the unit service valves and the charging manifold valves.
7. Open the nitrogen tank valve and pressurize the system to 360 psi (24.7 kg/cm²).
8. Perform leak tests.
9. If a leak is found, discharge and purge the system and repair leak. See specific instructions for components to be removed.
10. If a leak was not found and Refrigerant-R410A was used to pressurize the system, see charging instructions. To pressurize a system that has been discharged and purged, for leak testing with an electronic detector:

CAUTION

Connect the Refrigerant-410A drum so that only gas will be used for pressurization.

11. Remove the caps from the high and low-pressure service valves.
12. Connect the hoses from a charging manifold to the service valves.
13. Connect a drum of Refrigerant R-410A to the center hose connection of the charging manifold.
14. Open the unit service valves and the charging manifold valves.
15. Open the Refrigerant R-410A drum valve slightly and adjust as necessary to prevent formation of frost, and allow system pressure to build up until the gages read 40-50 psi (2.8-3.5 kg/cm²).
16. Close the charging manifold valves and the Refrigerant R-410A drum valve.
17. Remove the Refrigerant-R-410A drum from the center hose connection.
18. Connect a nitrogen regulator and cylinder of dry nitrogen to the center hose connection.
19. Open the charging manifold valves and the nitrogen cylinder and regulator valve, allow system pressure to build up until gages read 350 psi (24.7 kg/cm²).
20. Perform leak tests, then discharge and purge the system, in accordance with this WP, WP 0039 and WP 0041 before performing maintenance, as appropriate. Always perform a final leak test after performing any repair or replacement of components before the environmental control unit is reassembled and the refrigeration system is evacuated and charged.

END OF WORK PACKAGE

FIELD LEVEL

24,000 BTUH, SPLIT PACK ENVIRONMENTAL CONTROL UNIT (ECU)

NSN 4120-01-516-4715

F24H4-2

EVACUATING THE REFRIGERANT R-410A SYSTEM

0041 00

INITIAL SETUP:

Personnel Required

Unit Level Technician (1)

Tools And Special Tools

Tool Kit, Refrigeration Ordnance
5180-00-596-1474

Equipment Condition

Air conditioner removed from shelter, if
necessary.

Refrigerant R-410A system discharged (See

EVACUATING THE REFRIGERANT R-410A
SYSTEM).

Refrigerant R-410A system purged (See WP
0040 00, LEAK TESTING THE REFRIGERANT
R-410A SYSTEM).

Refrigerant R-410A system checked for leaks
(See WP 0040 00, LEAK TESTING THE
REFRIGERANT R-410A SYSTEM).

New filter-drier installed (See WP 0030 00,
FILTER-DRYER REFRIGERANT).

References

SERVICING

The refrigeration system must be evacuated to remove all moisture before it is charged with Refrigerant R-410A.

CAUTION

Don't evacuate a leaking system. The vacuum created can cause air, moisture, and dirt to enter system.

1. Check that both service valves and charging manifold valves are closed.
2. Attach hose assemblies to service valves and charging manifold valves.
3. Attach center hose assembly to vacuum pump.
4. Start vacuum pump.
5. Open charging manifold valves.
6. Open both unit service valves.
7. Run the vacuum pump until at least 29 inches of mercury, measured on the gage is reached.

NOTE

Inability to reach 29 inches of mercury may indicate either a leak or a problem with the pump.

8. Continue running the pump for one more hour, while observing the gage. If the gage needle moves back and forth, you have a leak, which must be located and corrected first.
9. Close charging manifold valves.
10. Close both unit service valves.
11. Stop vacuum pump.
12. Disconnect pump from center hose connection.
13. Go to WP 0042 00, CHARGING THE REFRIGERANT R-410A SYSTEM , charging the refrigeration system.

END OF WORK PACKAGE

FIELD LEVEL

24,000 BTUH, SPLIT PACK ENVIRONMENTAL CONTROL UNIT (ECU)

NSN 4120-01-516-4715

F24H4-2

CHARGING THE REFRIGERANT R-410A SYSTEM

0042 00

INITIAL SETUP:

Personnel Required

Direct Support Technician (1)

Tools And Special Tools

Tool Kit, Refrigeration Ordnance
5180-00-596-1474

Equipment Condition

Air conditioner removed from shelter, if necessary.

Refrigerant R-410A system discharged (See WP 004100, EVACUATING THE REFRIGERANT R-410A SYSTEM).

Refrigerant R-410A system purged (See WP 0040 00, LEAK TESTING THE REFRIGERANT R-410A SYSTEM) Any brazing/debrazing procedure completed (See WP 0043 00, BRAZING/DEBRAZING PROCEDURES) Refrigerant R-410A system evacuated (See WP 0041 00, EVACUATING THE REFRIGERANT R-410A SYSTEM)

References

SERVICING

After the system has been satisfactorily evacuated, it must be fully charged with Refrigerant-R-410A.

CAUTION

Never introduce liquid Refrigerant R-410A into the low pressure (suction) service valve.

NOTE

The system must be evacuated before charging. Use only Refrigerant-R-410A to charge the unit.

1. Check that the hose (13) from the low-pressure service valve (1) is connected to the compound gage (8) side of the charging manifold. The hose (4) from the high-pressure service valve (3) should be connected to the pressure gage (6) side of the charging manifold. See Figure 1
2. Connect the center hose (12) from the charging manifold to a drum of Refrigerant-R-410A (10). Open manifold supply valve (7). See Figure 1

3. Loosen the hose connections (1, 3) to the two environmental control unit service valves slightly. See Figure 1.
4. Open the two charging manifold valves (5, 9).
5. Open the Refrigerant-R-410A drum (10) valve slightly to allow a small amount of Refrigerant R-410A to purge air from the hoses. Tighten the hose connections at the environmental control unit valves.
6. Close the low pressure (suction) charging manifold valve (9). Never introduce liquid Refrigerant R-R-410A into the low-pressure (suction) service valve.
7. Position the Refrigerant-R-410A drum (10) so that liquid will be used for charging. (Some drums must be inverted and some are equipped with a selector valve.)
8. Using accurate scales (11) measure and record the weight of the Refrigerant-R-410A drum.
9. Open the Refrigerant-R-410A drum valve.
10. Open the high-pressure service valve (6) on the environmental control unit. Allow liquid Refrigerant R-410A to enter the system until the drum weight has decreased by 4.9 pounds (2.23 Kg) or until system pressure has equalized.
11. Close the Refrigerant R-410A drum valve and the high-pressure (discharge) manifold valve (6).
Figure 1
12. Close manifold supply valve (7).
13. Connect environmental control unit to a remote control module assembly.
14. Connect power.

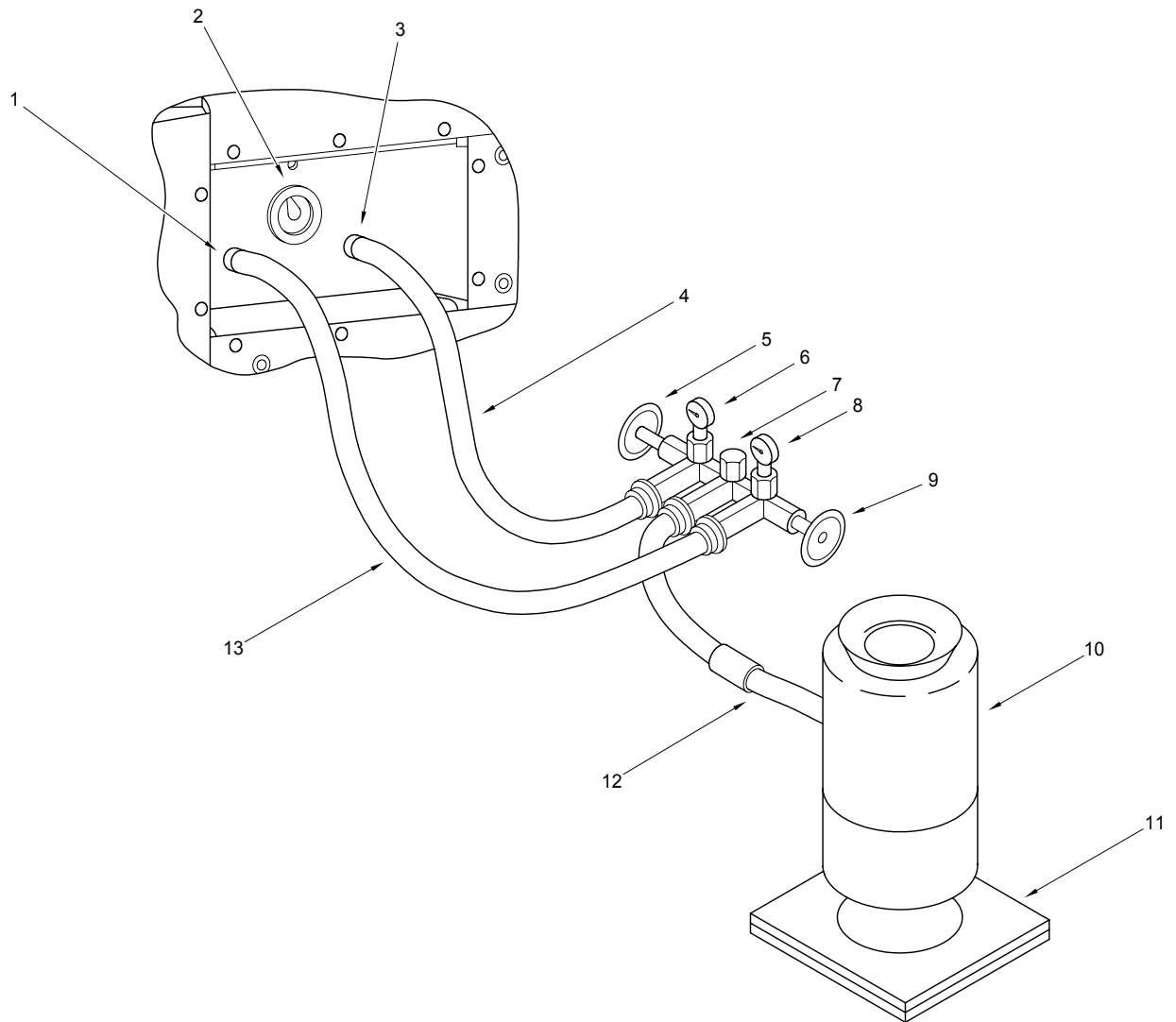

Figure 1. R410-A CHARGING SYSTEM.

14. Turn air conditioner on and operate in the COOL mode with the TEMPERATURE control set at the maximum COOLER position. (See WP 0005 00)
15. If the 4.9 pounds (2.23 kg) full charge was obtained, skip steps 16 through 19. If the system pressure equalized prior to obtaining a full charge of 4.9 pounds (2.23 kg) proceed with step 16.
16. Switch the Refrigerant R-410A drum (10) to the gas only position.
17. Be sure that the Refrigerant R-410A drum has been switched to the gas position and open the Refrigerant R-410A drum valve, the low (suction) pressure charging manifold valve (9) and the low (suction) pressure service valve (1) on the environmental control unit.
18. Monitor the weight of the Refrigerant R-410A drum as the environmental control unit compressor pulls additional Refrigerant R-410A gas into the system until the full 4.9 pound (2.23 kg.) charge is obtained. When the system is fully charged, immediately close the Refrigerant R-410A drum valve (1) and the environmental control unit low-pressure service valve (9).
19. Run the ECU in COOL mode (with TEMPERATURE control in full COOLER position) for 15 or 20 minutes. After such time, observe the sight glass (2) on back of condenser section.
 - a. Green center on the sight glass (2) means the Refrigerant R-410A moisture content is acceptable.
 - b. Yellow center means there is too much moisture in the system. It must be discharged, evacuated and charged again.
 - c. Milky white or bubbly liquid means the system has a low charge.
 - d. Clear bubble-free liquid around the center means the system is fully charged.
20. If charge is low, add gas Refrigerant R-410A.
 - a. Be sure that drum (10) is switched to gas position. Open the supply valve (7) and the air conditioner low- pressure service valve (9).
 - b. Continue to charge until sight glass (2) is clear and bubble-free.
 - c. Close the Refrigerant R-410A drum supply valve (7) and the environmental control unit low-pressure service valve (9).
21. Check environmental control unit for proper cooling. There should be at least a 20-degree plus/minus 5-degree temperature difference between evaporator discharge air and the inlet air.
22. Turn the MODE selector switch to OFF. (See WP 0005 00)
23. Close the high (5) and low-pressure (9) environmental control unit valves, and remove the charging manifold hoses from the environmental control unit service valves (1 & 3).
24. Go to **CHARGING THE REFRIGERANT R-410A SYSTEM.**

END OF WORK PACKAGE

FIELD LEVEL

24,000 BTUH, SPLIT PACK ENVIRONMENTAL CONTROL UNIT (ECU)

NSN 4120-01-516-4715

F24H4-2

BRAZING/DEBRAZING PROCEDURES

0043 00

INITIAL SETUP:

Abrasive Cloth 5350-00-192-5047 (1)

Personnel Required

Rags 7920-00-205-1711 (1)

Direct Support Technician (1)

Tools And Special Tools

Tool Kit, Refrigeration Ordnance
5180-00-596-1474

Equipment Condition

Air conditioner removed from shelter, if necessary Refrigerant R-410A system discharged (See WP 0041 00, EVACUATING THE REFRIGERANT R-410A SYSTEM) Refrigerant R-410A system purged (See WP 0040 00, LEAK TESTING THE REFRIGERANT R-410A SYSTEM)

Materials/Parts

Nitrogen 6830-00-292-0732 (1)
Brazing Alloy, Silver QQ-B-564, grade 0, I, or II (1)
Brazing Alloy, Silver QQ-B-564, grade III (1)
Brazing Flux O-F-499, Type B

References

DISASSEMBLY

General. All tubing in the refrigeration system is seamless copper with a bright internal finish that permits thorough cleaning and prevents entrapment of moisture or other impurities. Rigid grade copper is used for straight sections and soft grade for sections that must be bent. All interconnecting fittings, such as elbows, tees, etc., are also copper. The bodies of all valves and all connections on other components are brass. All joints, except those provided with flare fittings, are made by brazing in accordance with MIL-B-7883, except that radiographic examination is not required. Filler Alloy. Grade IV or VI brazing alloy and type B flux, as specified in MIL-B-7883, must be used for all copper to brass joints, Grade III brazing may be substituted for Grade IV or VI for copper to copper joints; flux is not required for copper to copper joints.

CAUTION

Be sure the refrigeration system is fully discharged and purged and that dry nitrogen is flowing through the system at the rate of less than 1-2 cfm (0.028-0.057 m³/minute) before all brazing or debrazing operations.

DEBRAZING.

1. Determine which joints are to be debrazed. Due to the limited workspace inside the air conditioner, it may be more convenient to remove a part of the interconnecting tubing with the component rather than debrazing the joints on the component itself.

WARNING

The burning of polyurethane foams is dangerous. Due to chemical composition of polyurethane foam, toxic fumes are released when it is burned or heated. If it is burned or heated indoors, such as during a welding operation nearby, you should take care to ventilate the area thoroughly. An exhaust system like that of a paint spray booth should be used. Air-supplied respirators, approved by the National Institute for Occupational Safety and Health Administration or the United States Bureau of Mines, should be used for all welding in confined spaces and in places where ventilation is inadequate. Persons who have chronic or recurrent respiratory conditions, including allergies and asthma, should not work in these areas.

2. Before debrazing a joint on a valve, disassemble the valve to the extent possible, and then wrap all but the joint with a wet rag to act as a heat sink.
3. Protect insulation, wiring harnesses, cabinet, and other surrounding components with appropriate shields.
4. Be sure the work area is well ventilated and that dry nitrogen is flowing through the refrigeration system at a rate of less than 1 - 2 cfm (0.028 - 0.057 cubic meters/minute).
5. Apply sufficient heat uniformly around the joint to quickly melt the filler alloy. If heat is applied slowly, or only on one side, the entire component or length of tubing will be heated and filler alloy in adjacent joints may also be melted. Remove heat as soon as the joint separates.

CLEANING

All filler alloy must be cleaned from debrazed joints before reassembly. Heat each piece of the joint until the filler alloy is melted and then wipe it away with a damp cloth. Be sure no filler alloy or other debris are left inside any tubing, fitting, or component.

ASSEMBLY

1. If tubing sections or fittings were removed with a component, debraze them from the component, clean the joints, and braze them to the new component before reinstallation.

BRAZING

1. Position the component to be installed.
2. To prepare a joint on a valve for brazing, disassemble the valve to the extent possible. Wrap all but the joint with a wet rag to act as a heat sink.
3. Protect insulation, wiring harnesses, and surrounding components with appropriate shields.
4. Be sure the work area is well ventilated and that dry nitrogen is flowing through the refrigeration system at a rate of less than 1 - 2 cfm (0.028 - 0.057 cubic meters/minute).
5. Apply sufficient heat uniformly around the joint to quickly raise it to a temperature that will melt the filler alloy. Remove heat as soon as brazing is completed.

END OF WORK PACKAGE

FIELD LEVEL

24,000 BTUH, SPLIT PACK ENVIRONMENTAL CONTROL UNIT (ECU)

NSN 4120-01-516-4715

F24H4-2

FINISH REPAINTING AND REFINISHING GENERAL

0044 00

INITIAL SETUP:

Personnel Required

Unit Level Technician (1)

References

TB 43-0118

TB 43-0139

Tools And Special Tools

Refer to SB 11-573, painting and preservation supplies available for field use for electronics command equipment. (1)

Materials/Parts

Yellow primer

MIL-P-52192 or TT-P-1757 (1)

Forest green enamel MIL-E-52798 (1)

Equipment Condition

Air conditioner removed from shelter if necessary (See WP 0005 00, INSTALLATION SITE PREPARATION)

PAINTING

1. Touch up and repaint in accordance with TB 43-0118, field instructions, for painting and preserving electronics command equipment.
2. Care for painting equipment in accordance with TM 43-0139, painting instructions for field use.

END OF WORK PACKAGE

FIELD LEVEL

24,000 BTUH, SPLIT PACK ENVIRONMENTAL CONTROL UNIT (ECU)

NSN 4120-01-516-4715

F24H4-2

WIRING DIAGRAMS

0045 00

NOTE

Environmental Control Unit schematic diagrams do not depict shelter electrical connectors. Evaporator Main Power connector (J1) and Remote Control connector (J2) connect to vehicle shelter Main Power cable connector (J8) and Remote Control cable connector (J7) . Remote Control Unit connector (P2) connects to vehicle shelter Remote Control cable connector (J14).

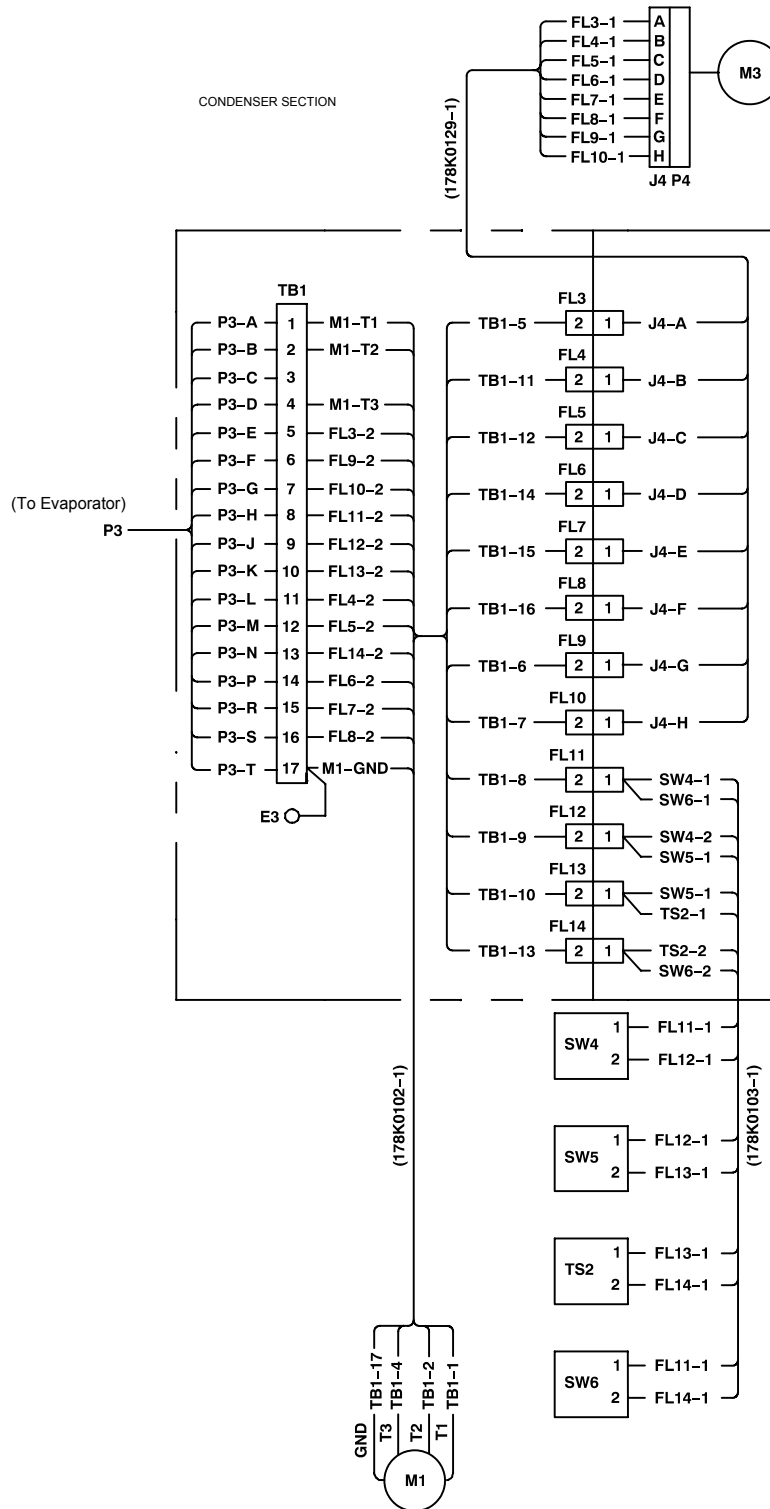

Figure 1. WIRING DIAGRAM (Sheet 1 of 4).

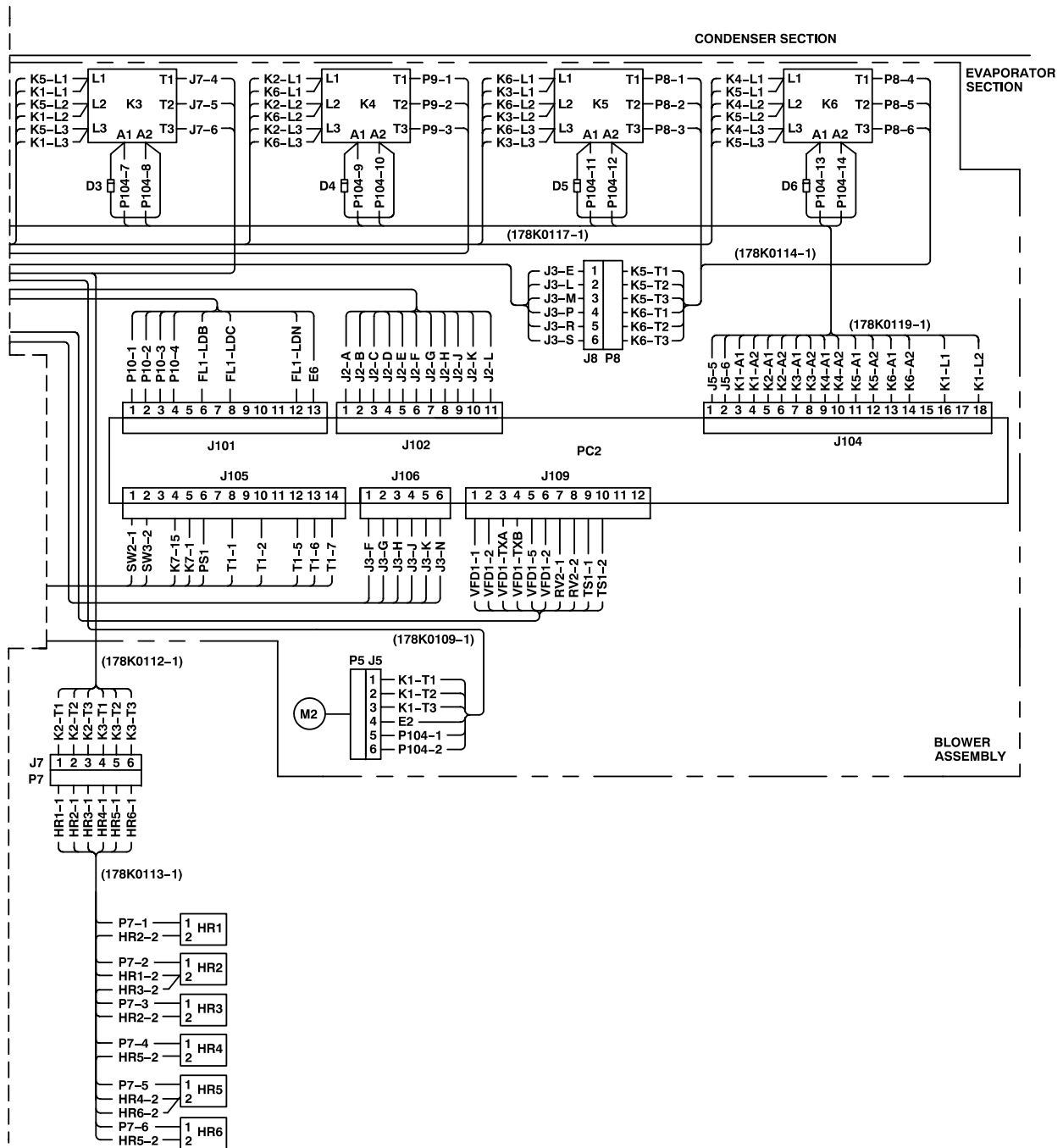

Figure 1. WIRING DIAGRAM (Sheet 3 of 4).

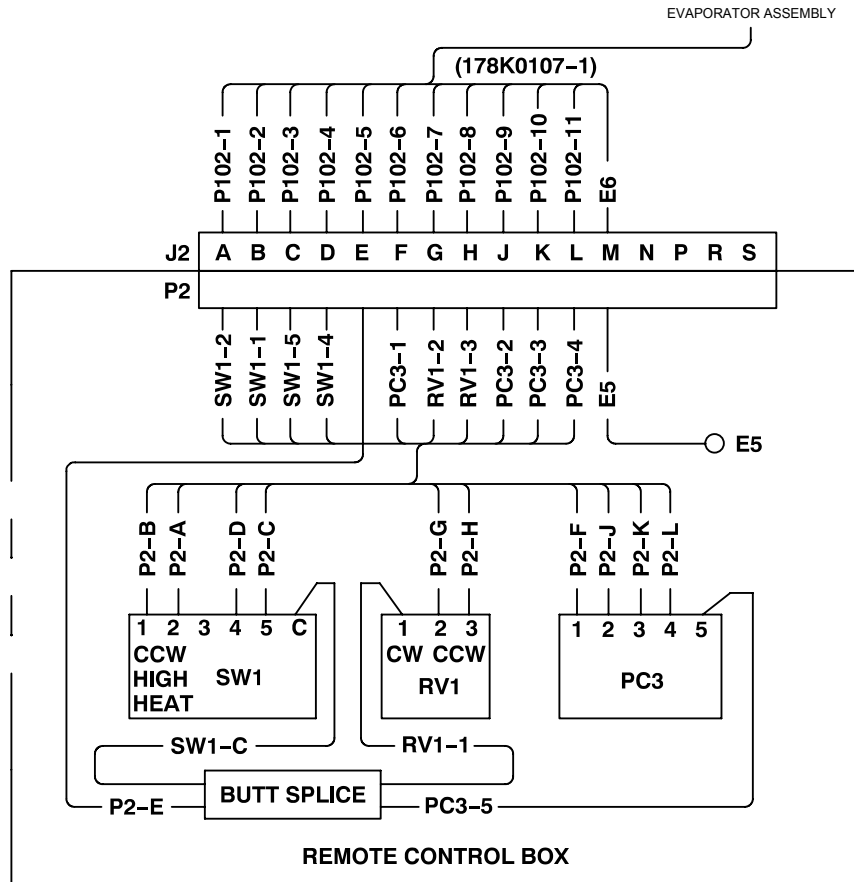

Figure 1. WIRING DIAGRAM (Sheet 4 of 4).

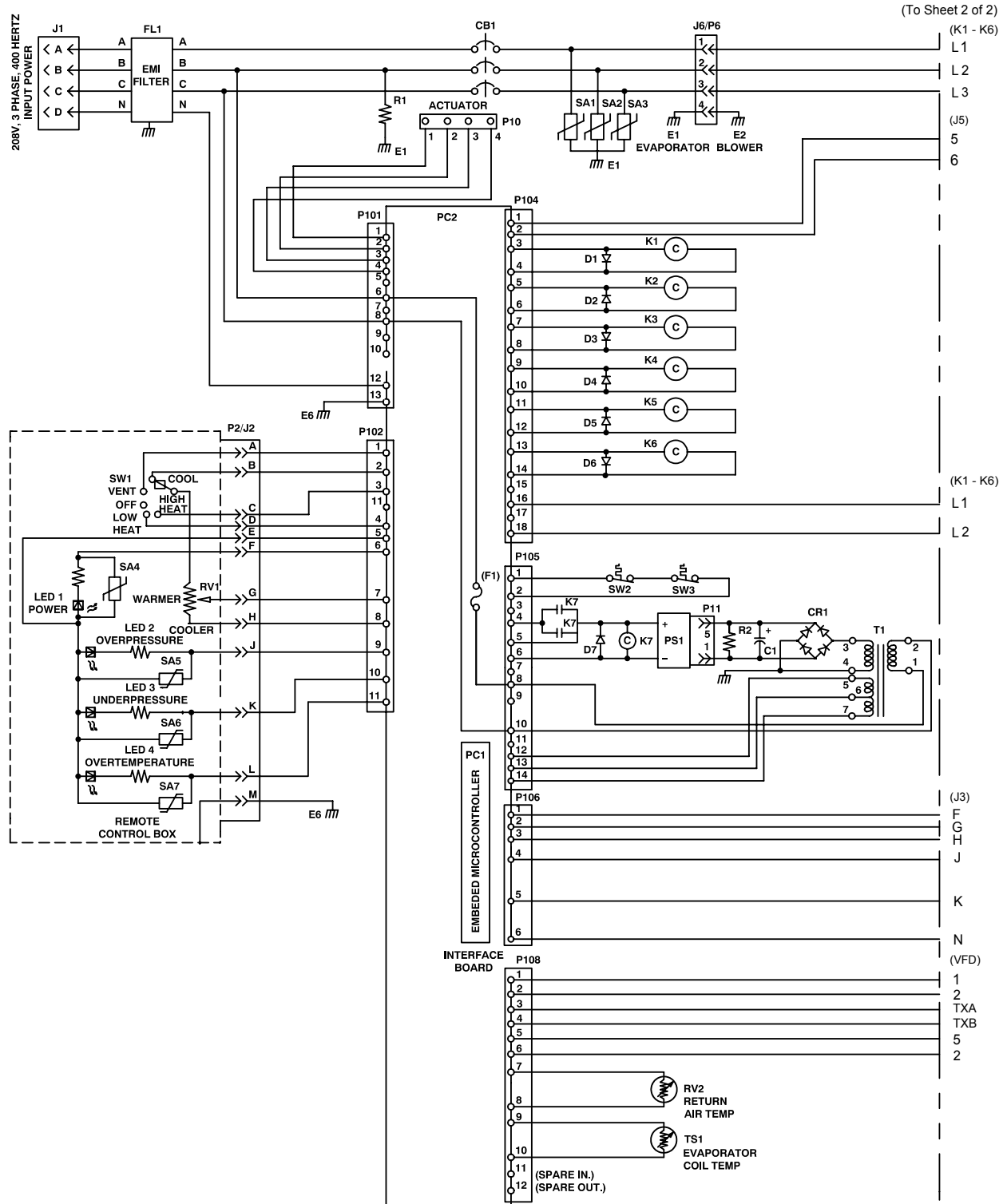

Figure 2. SCHEMATIC ELECTRICAL (Sheet 1 of 2).

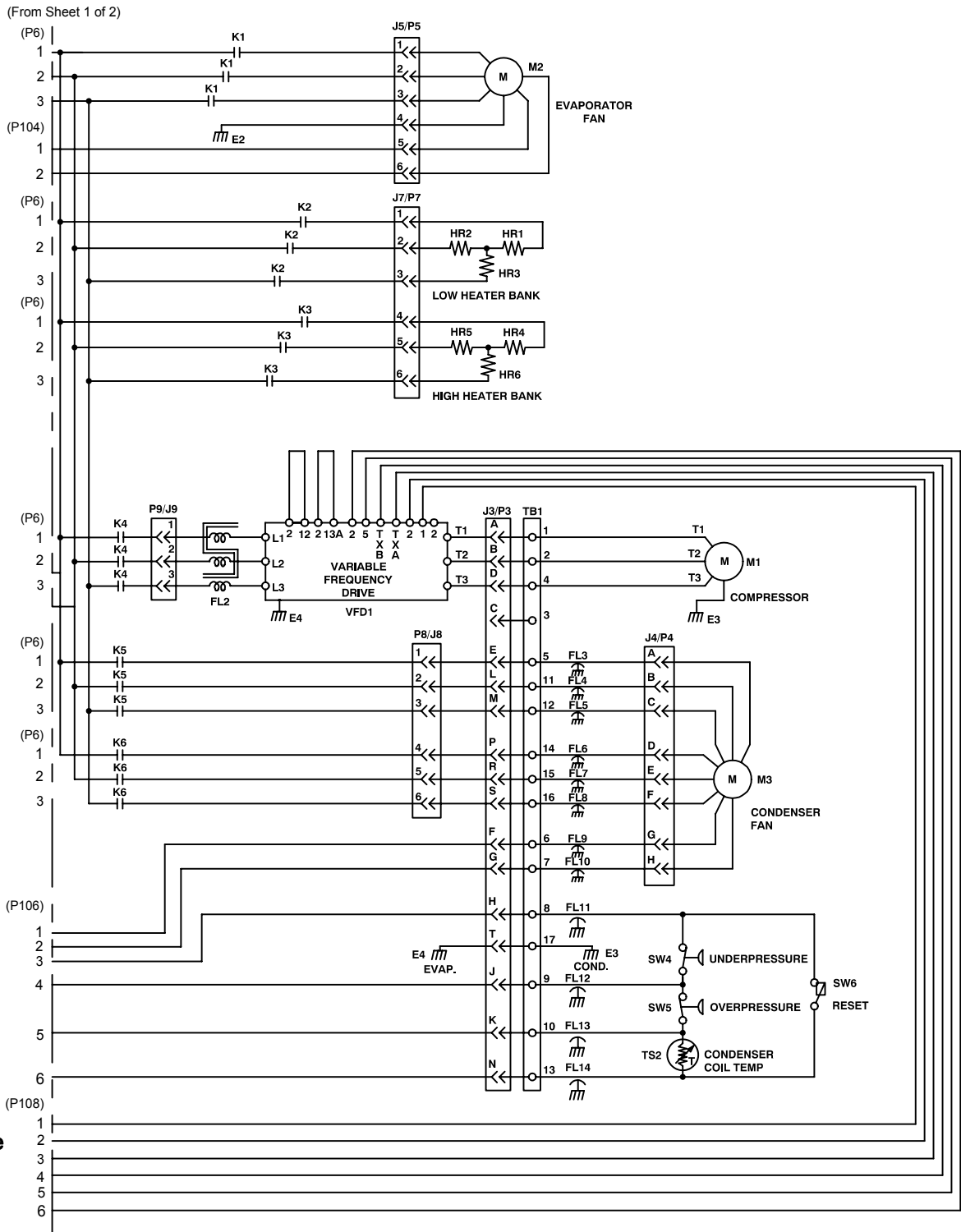

Figure 2.

SCHEMATIC ELECTRICAL (Sheet 2 of 2).

Chapter 5

OPERATOR

24,000 BTUH, SPLIT PACK ENVIRONMENTAL CONTROL UNIT (ECU)

NSN 4120-01-516-4715 F24H4-2

OPERATOR

24,000 BTUH, SPLIT PACK ENVIRONMENTAL CONTROL UNIT (ECU)

NSN 4120-01-516-4715

F24H4-2

**SUPPORTING DATA WORK PACKAGE FOR REPAIR PART SPECIAL TOOLS, TMDE,
AND SUPPORT EQUIPMENT**

0046 00

SCOPE

Repair parts are listed and illustrated in TM 9-4120-429-24P. No special tools are required for maintenance of the equipment.

For authorized common tools and equipment refer to the Modified Table of Organization and Equipment (MTOE) applicable to your unit.

No special tools are required for unit maintenance of this equipment. All common hand tools required by unit maintenance can be found in the Tool Kit, Service, Refrigeration Unit, NSN 5180-00-597-1474.

Test, maintenance, and diagnostic equipment (TMDE) and support equipment include electrical test equipment, standard pressure and vacuum gages, vacuum pumps and charging manifolds found as standard equipment in any direct support refrigeration shop.

EQUIPMENT INSPECTION AND MAINTENANCE WORK SHEET

DA Form 2404

RECOMMENDED CHANGES TO PUBLICATIONS AND BLANK FORMS

DA Form 2028

PRODUCT QUALITY DEFICIENCY REPORT

SF 368

ELECTRIC POWER GENERATION IN THE FIELD

FM 20-31

THEATER OPERATIONS ELECTRICAL SYSTEMS

FM5-424

REPAIR PARTS AND SPECIAL TOOLS LIST

TM 9-4120-419-24P

ADMINISTRATIVE STORAGE OF EQUIPMENT

PAM 25-30

HAND PORTABLE FIRE EXTINGUISHERS APPROVED FOR ARMY USERS

TB 5-4200-200-10

PAINTING INSTRUCTIONS FOR ARMY MATERIEL

TM 43-0139

PROCEDURES FOR DESTRUCTION OF EQUIPMENT TO PREVENT ENEMY USE

TM 750-244-3

HIGH FREQUENCY COMMUNICATIONS

FM11-65

THE ARMY MAINTENANCE MANAGEMENT SYSTEM

DA PAM 750-8

**FIELD INSTRUCTIONS FOR PAINTING AND PRESERVING COMMUNICATIONS-ELECTRONICS
EQUIPMENT**

TB 43-0118

FUELS, LUBRICANTS, OILS, AND WAXES

C91001L

END OF WORK PACKAGE

OPERATOR

24,000 BTUH, SPLIT PACK ENVIRONMENTAL CONTROL UNIT (ECU)

NSN 4120-01-516-4715

F24H4-2

THE ARMY MAINTENANCE SYSTEM MAC

0047 00

INTRODUCTION

This introduction provides a general explanation of all maintenance and repair functions authorized at various maintenance levels under the standard Army Maintenance System concept.

The MAC (immediately following the introduction) designates overall authority and responsibility for the performance of maintenance functions on the identified end item or component. The application of the maintenance functions to the end item or component shall be consistent with the capacities and capabilities of the designated maintenance levels, which are shown on the MAC in column (4) as:

Field - includes two sub columns, Operator/Crew (C), Unit (O) maintenance and Direct Support (F) maintenance.

Sustainment - includes two sub columns, General Support (H) and Depot (D) maintenance
The tools and test equipment requirements (immediately following the MAC) list the tools and test equipment (both special tools and common tool sets) required for each maintenance function as referenced from the MAC.

The remarks (immediately following the tools and test equipment requirements) contain supplemental instructions and explanatory notes for a particular maintenance function.

MAINTENANCE FUNCTIONS

Maintenance functions are limited to and defined as follows:

1. *Inspect.* To determine the serviceability of an item by comparing its physical, mechanical, and/or electrical characteristics with established standards through examination (e.g., by sight, sound, or feel). This includes scheduled inspection and gagings and evaluation of cannon tubes.
2. *Test.* To verify serviceability by measuring the mechanical, pneumatic, hydraulic, or electrical characteristics of an item and comparing those characteristics with prescribed standards on a scheduled basis, i.e., load testing of lift devices and hydrostatic testing of pressure hoses.
3. *Service.* Operations required periodically to keep an item in proper operating condition, e.g., to clean (includes decontaminate, when required), to preserve, to drain, to paint, or to replenish fuel, lubricants, chemical fluids, or gases. This includes scheduled exercising and purging of recoil mechanisms.
4. *Adjust.* To maintain or regulate, within prescribed limits, by bringing into proper position, or by setting the operating characteristics to specified parameters.
5. *Align.* To adjust specified variable elements of an item to bring about optimum or desired performance.
6. *Calibrate.* To determine and cause corrections to be made or to be adjusted on instruments of test, measuring, and diagnostic equipment used in precision measurement. Consists of comparisons of two instruments, one of which is a certified standard of known accuracy, to detect and adjust any discrepancy in the accuracy of the instrument being compared.

7. *Remove/Install*. To remove and install the same item when required to perform service or other maintenance functions. Install may be the act of emplacing, seating, or fixing into position a spare, repair part, or module (component or assembly) in a manner to allow the proper functioning of an equipment or system.
8. *Replace*. To remove an unserviceable item and install a serviceable counterpart in its place. The MAC authorizes "Replace" and assigned maintenance level is shown as the third position code of the Source, Maintenance and Recoverability (SMR) code.
9. *Repair*. The application of maintenance services, including fault location/troubleshooting, removal/installation, disassembly/assembly procedures, and maintenance actions to identify troubles and restore serviceability to an item by correcting specific damage, fault, malfunction, or failure in a part, subassembly, module (component or assembly), end item, or system.

NOTE

The following definitions are applicable to the "repair" maintenance function: Services - Inspect, test, service, adjust, align, calibrate, and/or replace.

- a. Fault location/troubleshooting - The process of investigating and detecting the cause of equipment malfunctioning; the act of isolating a fault within a system or Unit Under Test (UUT).
 - b. Disassembly/assembly - The step-by-step breakdown (taking apart) of a spare/functional group coded item to the level of its least component, that is assigned an SMR code for the level of maintenance under consideration (i.e., identified as maintenance significant).
 - c. Actions - welding, grinding, riveting, straightening, facing, machining, and/or resurfacing.
10. *Overhaul*. That maintenance effort (service/action) prescribed to restore an item to a completely serviceable/operational condition as required by maintenance standards in appropriate technical publications.

NOTE

Overhaul is normally the highest degree of maintenance performed by the Army. Overhaul does not normally return an item to like new condition.

11. *Rebuild*. Consists of those services/actions necessary for the restoration of unserviceable equipment to a like new condition in accordance with original manufacturing standards. Rebuild is the highest degree of materiel maintenance applied to Army equipment. The rebuild operation includes the act of returning to zero those age measurements (e.g., hours/miles considered in classifying Army equipment/components).

EXPLANATION OF COLUMNS IN MAINTENANCE ALLOCATION CHART (MAC)

Column (1) Group Number. Column (1) lists FGC numbers, the purpose of which is to identify maintenance significant components, assemblies, subassemblies, and modules with the Next Higher Assembly (NHA).

Column (2) Component/Assembly. Column (2) contains the item names of components, assemblies, subassemblies, and modules for which maintenance is authorized.

Column (3) Maintenance Function. Column (3) lists the functions to be performed on the item listed in column (2). (For a detailed explanation of these functions, refer to *Maintenance Functions* outlined above.)

Column (4) Maintenance Level. Column (4) specifies each level of maintenance authorized to perform each function listed in column (3), by indicating work time required (expressed as man-hours in whole hours or decimals) in the appropriate sub column. This work time figure represents the active time required to perform that maintenance function at the indicated level of maintenance. If the number or complexity of the tasks within the listed maintenance function varies at different maintenance levels, appropriate work time figures are to be shown for each level. The work time figure represents the average time required to restore an item (assembly, subassembly, component, module, end item, or system) to a serviceable condition under typical field operating conditions. This time includes preparation time (including any necessary disassembly/assembly time), troubleshooting/fault location time, and quality assurance time in addition to the time required to perform the specific tasks identified for the maintenance functions authorized in the MAC. The symbol designations for the various maintenance levels are as follows:

Field:

C - Operator or crew maintenance

O - Unit maintenance

F - Direct support maintenance

Sustainment:

D - Depot maintenance

H - General support maintenance

Column (5) Tools and Equipment Reference Code. Column (5) specifies, by code, those common tool sets (not individual tools), common Test, Measurement, and Diagnostic Equipment (TMDE), and special tools, special TMDE and special support equipment required Codes are keyed to the entries in the tools and test equipment table

Column (6) Remarks Code. When applicable, this column contains a letter code, in alphabetical order, which is keyed to the remarks table entries. Explanation of Columns in the Tools and Test Equipment Requirements

EXPLANATION OF COLUMNS IN THE TOOLS AND TEST EQUIPMENT REQUIREMENTS

Column (1) Tool or Test Equipment Reference Code. The tool or test equipment reference code correlates with a code used in column (5) of the MAC.

Column (2) Maintenance Level. The lowest level of maintenance authorized to use the tool or test equipment.

Column (3) Nomenclature. Name or identification of the tool or test equipment.

Column (4) National Stock Number (NSN). The NSN of the tool or test equipment.

Column (5) Tool Number. The manufacturer's part number, model number, or type number.
Explanation of Columns in the Remarks

EXPLANATION OF COLUMNS IN THE REMARKS

Column (1) Remarks Code. The code recorded in column (6) of the MAC.

Column (2) Remarks. This column lists information pertinent to the maintenance function being performed as indicated in the MAC.

Table 1. MAC for 24,000 BTUH, SPLIT PACK ENVIRONMENTAL CONTROL UNIT (ECU)

Table 2. Tools and Test Equipment for 24,000 BTUH, SPLIT PACK ENVIRONMENTAL CONTROL UNIT (ECU)

Table 3. Remarks for 24,000 BTUH, SPLIT PACK ENVIRONMENTAL CONTROL UNIT (ECU)

END OF WORK PACKAGE

OPERATOR

24,000 BTUH, SPLIT PACK ENVIRONMENTAL CONTROL UNIT (ECU)

NSN 4120-01-516-4715 F24H4-2

Table 1. MAINTENANCE ALLOCATION CHART

0048 00

(1) Group Number	(2) Component/ Assembly	(3) Maintenance Function	(4) Maintenance Level					(5) Tools and Equipment Ref Code	(6) Remarks Code
			Field			Sustainment			
			C	O	F	H	D		
00	24000 BTUH Split Pack ECU	Inspect Test Service Replace Repair	0.2 0.5 0.5	0.2 1.0 1.0 2.0 2.0	1.5				
01	Evaporator Assy	Inspect Test Service Adjust Remove/Install Repair Repair		0.5 2.0	1.5 0.2 1.0 2.0 6.0		1 1 1,3,6,7	A B	
0101	Filter Radio Freq Interference	Inspect Test Remove/Install		0.2 0.3 1.0				K	
0102	Housing Assy	Remove/Install Inspect Repair		8.0 0.3 2.0			1 1	E	
0103	Evaporator Coil Assy	Remove/Install Inspect Test Service			2.0 0.1 0.3 0.3		1,3,6,7 1		
0104	Heater Assy	Remove/Install Inspect Test Repair		1.0 0.1 0.3 0.5			1 9		
0105	Blower and Motor Assy	Remove/Install Inspect Test Repair		2.0 0.2 0.3 1.0			1 9		

Table 1. Maintenance Allocation Chart.

(1) Group Number	(2) Component/ Assembly	(3) Maintenance Function	(4) Maintenance Level					(5) Tools and Equipment Ref Code	(6) Remarks Code
			Field			Sustainment			
			C	O	F	H	D		
010501	Evaporator Motor	Inspect Test Remove/Install		0.2 0.3 1.0					L
010502	Circuit Card Assembly, Control	Remove/Install Inspect Test Repair		1.0 0.2 0.5			3.0	1 9	I
010503	Relay Assembly	Remove/Install Inspect/Test Replace		0.5 0.5 0.5					
0106	Variable Freq Assy	Remove/Install Test Repair		1.2 1.0	1.0			1	
0107	Covers	Remove/Install Inspect Repair		1.2 0.4 3.5				1	C
0108	Harmonic Filter Assembly	Remove/Install Inspect Repair		0.5 0.1 0.5				1	
0109	Harness Assys	Remove/Install Inspect Test Repair		1.0 0.2 1.0 2.0				1,2 9 1,2	
0110	Thermostatic Valve	Remove/Install Inspect		0.5 0.2				1	
02	Condenser Assy	Inspect Remove/Install Test Service Repair Repair		0.5 2.0	2.0 1.5 0.5 6.0			1 1 1	F

Table 1. Maintenance Allocation Chart.

(1) Group Number	(2) Component/ Assembly	(3) Maintenance Function	(4) Maintenance Level					(5) Tools and Equipment Ref Code	(6) Remarks Code
			Field			Sustainment			
			C	O	F	H	D		
0201	Junction Box Assy	Remove/Install Inspect Repair		0.5 0.1 1.0				1	
0202	Covers	Remove/Install Inspect Repair Service		1.2 0.6 4.0 0.3				1 1	C G
0203	Coil Assy	Remove/Install Inspect Test Service			3.0 0.1 0.2 0.3			1,3,6,7 1	
0204	Blower and Motor Assy	Remove/Install Inspect Test Repair Service		2.0 0.2 0.3 1.0 0.1				1 9 1	D
020401	Condenser Motor	Inspect Test Remove/Install		0.2 0.3 1.0					L
0205	Condenser Housing	Remove/Install Inspect		1.0 0.2				1	
0206	Receiver Assy	Remove/Install Inspect			1.0 0.2			1	
0207	Filter-Dryer Assy	Remove/Install Inspect			1.0 0.2			1	
0208	Sight Glass	Remove/Install Inspect			1.0 0.2			1	
0209	Low Pressure Switch	Remove/Install Inspect			0.5 0.2			1,7,9,11	
0210	High Pressure Switch	Remove/Install Inspect			0.5 0.2			1,7,9,11	

Table 1. Maintenance Allocation Chart.

(1) Group Number	(2) Component/ Assembly	(3) Maintenance Function	(4) Maintenance Level					(5) Tools and Equipment Ref Code	(6) Remarks Code
			Field			Sustainment			
			C	O	F	H	D		
0211	Compressor Assy	Remove/Install Inspect Test Service Repair			4.0 0.1 0.7 1.0 1.0			1,3,6,7 1,9 10 1,3,6,7	H
0212	Harness Assys	Remove/Install Inspect Test Repair		1.0 0.2 1.0 2.0				1,2 9 1,2	
03	Remote Control	Remove Install Inspect		0.3 0.1				1	J

Table 2. Tools and Test Equipment.

Tool or Test Equipment Ref Code	Maintenance Level	Nomenclature	NSN	Tool Number
1	O-F	Tool Kit, service, Refrigeration Unit (SC 5180-90-CL-N18)	5180-00-597-1474	(19009) SC 5180 -90-CL-N18
2	O	Soldering Gun Kit	3439-00-930-1648	(11103) 350K4
3	F	Pump, Vacuum	4310-00-098-5272	(64484) 1400B
4	O-F	Overhead Lifting Device w/slings, 500 lb. capacity		
5	O	Installation Tool	5120-01-015-1422	(08524) H7503-8
6	F	Regulator, Pressure, Nitrogen	4935-00-040-9916	(00742) 231 P12805 RG5410A
7	F	Refrigerant Recovery Machine		
8	O	Heat Gun	4940-01-042-4855	
9	O-F	Multimeter	6625-01-265-6000	
10	F	Manifold Gage with Hoses R410A		(0PCX2)57361-J
11	F	Refrigerant Recovery Cylinder		

Table 3. Remarks for Environmental Control Unit.

Remarks Code	Remarks
A	Repair is limited to removal of drain plugs, electrical caps and covers, thermostatic switches, heating elements, EMI filters and screens.
B	Repair includes replacement of tubing and fittings.
C	Repair is limited to replacement of gaskets and/or insulation only.
D	Repair includes replacement of electrical connectors, fan inlet rings, impeller, blower housing, and base.
E	Replace insulation, lifting handles, blind nuts and plate nuts.
F	Repair includes replacement of sight glass, dehydrator, discharge bypass valve, valve mounting bracket, pressure switches, pressure relief valve, service valves, tubing and fittings.
G	Service is limited to cleaning condenser cover and EMI screens.
H	Replace external components only, including resilient mounts
I	Repair of the printed circuit board is performed by the manufacturer at the depot level.
J	Repair is limited to replacement of the remote control unit.
K	Repair is limited to replacement of the Filter Radio Frequency Interference
L	Repair is limited to replacement of the motor.

TM 9-4120-429-14

OPERATOR

24,000 BTUH, SPLIT PACK ENVIRONMENTAL CONTROL UNIT (ECU)

NSN 4120-01-516-4715

F24H4-2

COMPONENTS OF END ITEM (COEI) AND BASIC ISSUE

0049 00

ITEMS (BII) LISTS

Cover, Fabric. Condenser Assembly

0049 00-1/00-2 Blank

Chapter 6

INDEX

ALPHABETICAL INDEX

Subject	WP Seq. No.
A	
B	
Brazing/Debrazing Procedures Disassembly Assembly Cleaning	0043 00
C	
Compressor Assembly Inspection Remove/Install Repair/Replace	0034 00
Condenser Assembly Inspection Remove/Install Repair/Replace	0023 00
Condenser Covers Inspection Remove/Install Repair/Replace	0025 00
Condenser Coil Assembly Inspection Remove/Install Repair/Replace	0026 00
Condenser Blower and Motor Assembly Inspection Remove/Install Repair/Replace	0027 00
Remove/Install Inspection Test Repair	
Condenser Housing Inspection Remove/Install Repair/Replace	0028 00

Subject	WP Seq. No.
Condenser Harness Assemblies Inspection Remove/Install Repair/Replace	0036 00
Charging the Refrigerant R-410A System Service	0042 00
Components of End Item (COEI) and Basic Issue Items (BII) Lists	0049 00
D	
Description and Use of Operator's Controls and Indicators	0004 00
E	
Electrical Wiring Repair General	0037 00
Environmental Control Unit (ECU) unit Equipment Description and Data	0002 00
Equipment Description and Data	0002 00
Evacuating the Refrigerant R-410 System Service	0041 00
Evaporator Assembly and Condenser Assembly Disassembly Assembly	0012 00
Evaporator Assembly Inspection Remove/Install Repair/Replace	0013 00
Evaporator Housing Assembly Inspection Remove/Install Repair/Replace	0014 00
Evaporator Coil Assembly Inspection Remove/Install Repair/Replace	0015 00

Subject	E (continued)	WP Seq. No
Evaporator Blower and Motor Assembly Inspection Remove/Install Repair/Replace		0017 00
Evaporator Covers Inspection Remove/Install Repair/Replace		0019 00
Evaporator Harness Assemblies Inspection Remove/Install Repair/Replace		0021 00
Expansion Thermostatic Valve		0022 00-
	F	
Filter-Dryer Assembly Inspection Remove/Install		0030 00
Finish Repainting and Refinishing General Painting		0044 00
	G	
General Information		0001 00
	H	
Harmonic Filter FL2 Inspection Remove/Install Repair/Replace		0020 00
Heater Assembly Inspection Remove/Install Repair/Replace		0016 00
High Pressure Switch Test Remove/Install		0033 00

Subject	I	WP Seq. No.
Introduction For Standard Format Maintenance Allocation Chart (MAC)		0047 00
	J	
Junction Box Assembly Inspection Remove/Install Repair/Replace		0024 00
	K	
	L	
Leak Testing the Refrigerant R-410A System		0040 00
Low Pressure Switch Test Remove/Install		0032 00
	M	
Maintenance Allocation Chart (MAC)		0048 00
Maintenance Instructions		0011 00
Malfunction/Sympton Index		0007 00
	N	
	O	
Operation Under Usual Conditions		0005 00
Operation Under Unusual Conditions		0006 00
Operational and Checkout and Troubleshooting Procedures		0008 00

Subject		WP Seq. No.
	P	
PMCS (Field)		0010 00
	Q	
	R	
Receiver Assembly		0029 00
Refrigerant R-410-A Pressure Check Service		0039 00
Remote Control Unit Remove Install		0035 00
	S	
Service Upon Receipt		0009 00
Sight Glass Remove/Inspect Install		0031 00
Supporting Data for RPSTL, TMDE and Support Equipment		0046 00
	T	
Theory of Operation		0003 00
	U-V	
Variable Frequency Device (VFD) Inspection Remove/Install Test		0018 00
	W	
Wire List		0038 00
Wiring Diagrams		0045 00
	X-Z	

RECOMMENDED CHANGES TO PUBLICATIONS AND BLANK FORMS <small>For use of this form, see AR 25-30; the proponent agency is ODISC4.</small>	Use Part II (<i>reverse</i>) for Repair Parts and Special Tool Lists (RPSTL) and Supply Catalogs/Supply Manuals (SC/SM)	DATE <h2 style="text-align: center;">8/30/02</h2>
--	---	--

TO: (<i>Forward to proponent of publication or form</i>)(<i>Include ZIP Code</i>) Commander, U.S. Army C-E LCMC ATTN: AMSEL-LC-LEO-E-ED-P FORT MONMOUTH, NJ 07703-5000	FROM: (<i>Activity and location</i>)(<i>Include ZIP Code</i>) Jane Q. Doe, SFC 1234 Any Street Nowhere Town, AL 34565
---	--

PART 1 - ALL PUBLICATIONS (EXCEPT RPSTL AND SC/SM) AND BLANK FORMS

PUBLICATION/FORM NUMBER <h3 style="text-align: center;">TM 11-4940-355-12</h3>	DATE <h3 style="text-align: center;">16 Sep 2002</h3>	TITLE Organizational, Direct Support, And General Support Maintenance Manual for Machine Gun, .50 Caliber M3P and M3P Machine Gun Electrical Test Set Used On Avenger Air Defense Weapon System
---	--	---

ITEM NO.	PAGE NO.	PARA-GRAPH	LINE NO. *	FIGURE NO.	TABLE NO.	RECOMMENDED CHANGES AND REASON
1	WP0005 PG 3		2			Test or Corrective Action column should identify a different WP number. <div style="position: absolute; top: 50%; left: 50%; transform: translate(-50%, -50%) rotate(-45deg); font-size: 100px; opacity: 0.5; pointer-events: none;"> EXAMPLE </div>

* Reference to line numbers within the paragraph or subparagraph.

TYPED NAME, GRADE OR TITLE <h3 style="text-align: center;">Jane Q. Doe, SFC</h3>	TELEPHONE EXCHANGE/ AUTOVON, PLUS EXTENSION <h3 style="text-align: center;">788-1234</h3>	SIGNATURE
---	---	-----------

TO: (Forward direct to addressee listed in publication) Commander, U.S. Army C-E LCMC ATTN: AMSEL-LC-LEO-E-ED-P FORT MONMOUTH, NJ 07703-5000	FROM: (Activity and location) (Include ZIP Code) Jane Q. Doe, SFC 1234 Any Street Nowhere Town, AL 34565	DATE 8/30/02
--	--	------------------------

PART II - REPAIR PARTS AND SPECIAL TOOL LISTS AND SUPPLY CATALOGS/SUPPLY MANUALS

PUBLICATION NUMBER			DATE	TITLE				
PAGE NO.	COLM NO.	LINE NO.	NATIONAL STOCK NUMBER	REFERENCE NO.	FIGURE NO.	ITEM NO.	TOTAL NO. OF MAJOR ITEMS SUPPORTED	RECOMMENDED ACTION

PART III - REMARKS (Any general remarks, suggestions, or suggestions for improvement of publications and blank forms. Additional blank sheets may be used if more space is needed.)

EXAMPLE

TYPED NAME, GRADE OR TITLE Jane Q. Doe, SFC	TELEPHONE EXCHANGE/AUTOVON, PLUS EXTENSION 788-1234	SIGNATURE
--	--	-----------

RECOMMENDED CHANGES TO PUBLICATIONS AND BLANK FORMS						DATE
For use of this form, see AR 310-1; the proponent agency is the US Army Adjutant General Center.						Use Part II (reverse) for Repair Parts and Special Tool Lists (RPSTL) and Supply Catalogs/Supply Manuals (SC/SM).
TO: (Forward to proponent of publication or form) (Include ZIP Code)						FROM: (Activity and location) (Include ZIP Code)
PART I - ALL PUBLICATIONS (EXCEPT RPSTL AND SC/SM) AND BLANK FORMS						
PUBLICATION/FORM NUMBER					DATE	TITLE
ITEM NO.	PAGE NO.	PARA-GRAPH	LINE NO.*	FIGURE NO.	TABLE NO.	RECOMMENDED CHANGES AND REASON <i>(Exact wording of recommended change must be given)</i>
<i>* Reference to line numbers within the paragraph or subparagraph.</i>						
TYPED NAME, GRADE OR TITLE				TELEPHONE EXCHANGE/AUTOVON, PLUS EXTENSION		SIGNATURE

TO: <i>(Forward to proponent of publication or form) (Include ZIP Code)</i>	FROM: <i>(Activity and location) (Include ZIP Code)</i>	DATE
--	--	-------------

PART II- REPAIR PARTS AND SPECIAL TOOL LISTS AND SUPPLY CATALOGS/SUPPLY MANUALS

PUBLICATION/FORM NUMBER			DATE		TITLE			
PAGE NO.	COLM NO.	LINE NO.	FEDERAL STOCK NUMBER	REFERENCE NO.	FIGURE NO.	ITEM NO.	TOTAL NO. OF MAJOR ITEMS SUPPROTED	RECOMMENDED ACTION

PART III - REMARKS *(Any general remarks or recommendations, or suggestions for improvement of publications and blank forms. Additional blank sheets may be used if more space is needed.)*

TYPED NAME, GRADE OR TITLE	TELEPHONE EXCHANGE/AUTOVON, PLUS EXTENSION	SIGNATURE
----------------------------	--	-----------

RECOMMENDED CHANGES TO PUBLICATIONS AND BLANK FORMS						DATE
For use of this form, see AR 310-1; the proponent agency is the US Army Adjutant General Center.						Use Part II (reverse) for Repair Parts and Special Tool Lists (RPSTL) and Supply Catalogs/Supply Manuals (SC/SM).
TO: (Forward to proponent of publication or form) (Include ZIP Code)						FROM: (Activity and location) (Include ZIP Code)
PART I - ALL PUBLICATIONS (EXCEPT RPSTL AND SC/SM) AND BLANK FORMS						
PUBLICATION/FORM NUMBER					DATE	TITLE
ITEM NO.	PAGE NO.	PARA-GRAPH	LINE NO.*	FIGURE NO.	TABLE NO.	RECOMMENDED CHANGES AND REASON <i>(Exact wording of recommended change must be given)</i>
<i>* Reference to line numbers within the paragraph or subparagraph.</i>						
TYPED NAME, GRADE OR TITLE				TELEPHONE EXCHANGE/AUTOVON, PLUS EXTENSION		SIGNATURE

TO: <i>(Forward to proponent of publication or form) (Include ZIP Code)</i>	FROM: <i>(Activity and location) (Include ZIP Code)</i>	DATE
--	--	-------------

PART II- REPAIR PARTS AND SPECIAL TOOL LISTS AND SUPPLY CATALOGS/SUPPLY MANUALS

PUBLICATION/FORM NUMBER			DATE		TITLE			
PAGE NO.	COLM NO.	LINE NO.	FEDERAL STOCK NUMBER	REFERENCE NO.	FIGURE NO.	ITEM NO.	TOTAL NO. OF MAJOR ITEMS SUPPROTED	RECOMMENDED ACTION

PART III - REMARKS *(Any general remarks or recommendations, or suggestions for improvement of publications and blank forms. Additional blank sheets may be used if more space is needed.)*

TYPED NAME, GRADE OR TITLE	TELEPHONE EXCHANGE/AUTOVON, PLUS EXTENSION	SIGNATURE
----------------------------	--	-----------

RECOMMENDED CHANGES TO PUBLICATIONS AND BLANK FORMS						DATE
For use of this form, see AR 310-1; the proponent agency is the US Army Adjutant General Center.						Use Part II (reverse) for Repair Parts and Special Tool Lists (RPSTL) and Supply Catalogs/Supply Manuals (SC/SM).
TO: (Forward to proponent of publication or form) (Include ZIP Code)						FROM: (Activity and location) (Include ZIP Code)
PART I - ALL PUBLICATIONS (EXCEPT RPSTL AND SC/SM) AND BLANK FORMS						
PUBLICATION/FORM NUMBER					DATE	TITLE
ITEM NO.	PAGE NO.	PARA- GRAPH	LINE NO.*	FIGURE NO.	TABLE NO.	RECOMMENDED CHANGES AND REASON <i>(Exact wording of recommended change must be given)</i>
<i>* Reference to line numbers within the paragraph or subparagraph.</i>						
TYPED NAME, GRADE OR TITLE				TELEPHONE EXCHANGE/AUTOVON, PLUS EXTENSION		SIGNATURE

TO: <i>(Forward to proponent of publication or form) (Include ZIP Code)</i>	FROM: <i>(Activity and location) (Include ZIP Code)</i>	DATE
--	--	-------------

PART II- REPAIR PARTS AND SPECIAL TOOL LISTS AND SUPPLY CATALOGS/SUPPLY MANUALS

PUBLICATION/FORM NUMBER			DATE		TITLE			
PAGE NO.	COLM NO.	LINE NO.	FEDERAL STOCK NUMBER	REFERENCE NO.	FIGURE NO.	ITEM NO.	TOTAL NO. OF MAJOR ITEMS SUPPROTED	RECOMMENDED ACTION

PART III - REMARKS *(Any general remarks or recommendations, or suggestions for improvement of publications and blank forms. Additional blank sheets may be used if more space is needed.)*

TYPED NAME, GRADE OR TITLE	TELEPHONE EXCHANGE/AUTOVON, PLUS EXTENSION	SIGNATURE
----------------------------	--	-----------

By Order of the Secretary of the Army:

Official:



JOYCE E. MORROW
*Administrative Assistant to the
Secretary of the Army*
0712701

GEORGE W. CASEY, JR
*General, United States Army
Chief of Staff*

DISTRIBUTION:

To be distributed in accordance with the initial distribution number (IDN) 256913 requirements for TM 9-4120-429-14.

PIN: 083493-000